

Mini Ball Valve F/F

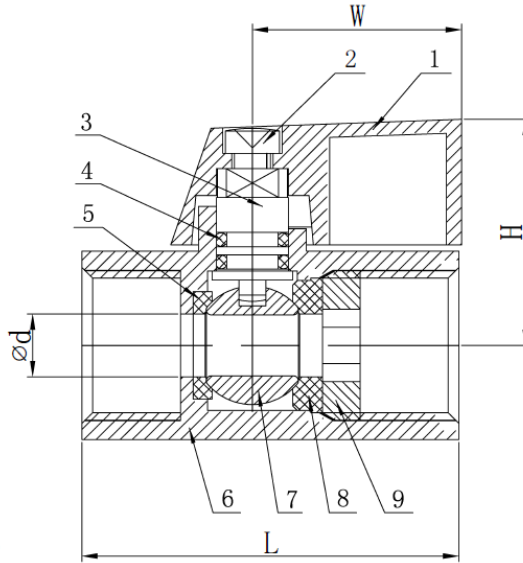

Features:

1. Temperature Range: - 20 to 180°C
2. Reduce Port
3. Investment Casting
4. Blow-out Proof Stem
5. PED 2014/68/EU
6. Sanitary Design
7. Thread: DIN2999/259, ISO228-1, ISO7/1, NPT
8. Inspection Testing: API598, EN12266-1

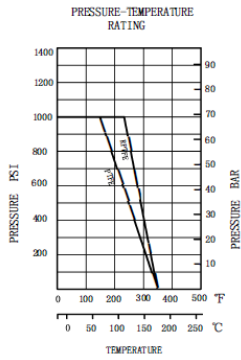

1"	15	65	34.5	23
3/4"	12.5	54	31	23
1/2"	9.2	46	27.5	23
3/8"	7	42	25	23
1/4"	7	42	25	23
1/8"	6.5	40	25	23
SIZE	d	L	H	W

9	CAP	CF8/CF8M	1
8	BALL SEAT (B)	PTFE/RPTFE	1
7	BALL	304/316	1
6	BODY	CF8/CF8M	1
5	BALL SEAT (A)	PTFE/RPTFE	1
4	"O"RING	NBR	2
3	STEM	304/316	1
2	BOLT	304	1
1	HANDLE	ALUMINUM ALLOY	1
NO.	NAME	MATERIAL	Q' TY

