

THERMOSTATIC STEAM TRAPS AND AIR ELIMINATORS TH 36 (DN 40 – DN 50)

DESCRIPTION

The TH36 series thermostatic steam traps and air eliminators are specifically designed for use on process equipment such as kettle cookers, sterilizers, food, chemical and laundry equipment where high discharge capacities are required.

Connections are screwed or flanged.

MAIN FEATURES

Modulating discharge.

Discharges condensate close to steam temperature.

Thermostats for different sub cooling (5°K to 30°K).

Excellent air discharge .

Operates on moderate superheated steam.

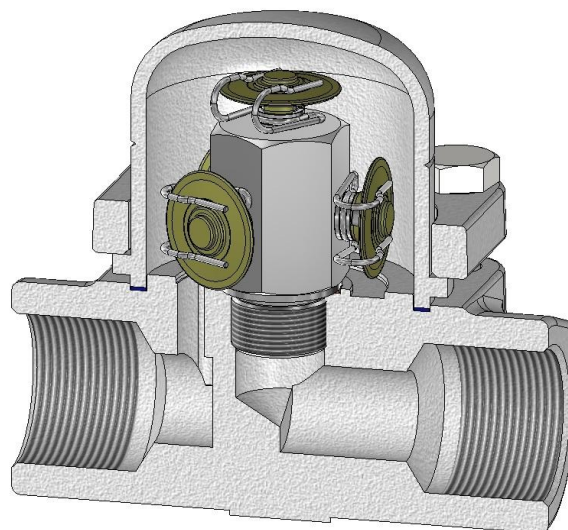

- OPTIONS:** Stainless steel construction
- USE:** Saturated steam.
- AVAILABLE MODELS:** TH36/4 – 4 capsules
TH36/6 – 6 capsules
- SIZES:** DN11/2" - 2"; DN 40 - DN 50
- CONNECTIONS:** Female screwed BSP or NPT
Flanged EN 1092-1 PN40 or ANSI
SW - Socket weld to ANSI B 16.11
BW - Butt weld to ANSI B16.25
- INSTALLATION:** Horizontal installation recommended, can be installed in any position. See IMI installation and maintenance instructions.

CE MARKING (PED - European Directive 97/23/EC)	
PN 40	Category
DN 40-50	1 (CE Marked)

BODY LIMITING CONDITIONS		
FLANGED PN40 / ANSI 300 *	FLANGED ANSI 150 **	RELATED TEMP.
ALLOW. PRES.	ALLOW. PRES.	
40 bar	19,3 bar	50 °C
35 bar	15,8 bar	150 °C
30,4 bar	12,1 bar	250 °C
27,6 bar	10,2 bar	300 °C

PMO - Max. operating pressure 22 bar

TMO - Max. operating temperature 250 °C

* According to EN1092-1:2007 ; ** Acc. to EN1759-1:2004

Body limiting conditions PN40 or below, depending on the type of connection adopted. Rating PN40 for thread, SW and BW.

FLOW RATE CAPACITY IN Kgs/h																
MODEL	SIZE	DIFFERENTIAL PRESSURE (bar)														
		0,2	0,3	0,5	1	1,5	2	3	4	6	8	10	13	15	20	22
TH36/4	40 - 50	280	480	560	1020	1320	1540	1820	2040	2400	2680	2800	2880	3000	3100	3180
TH36/6	40 - 50	420	720	840	1530	1980	2310	2730	3060	3600	4020	4200	4320	4500	4650	4770

Capacities shown refer to condensate at 10°C below saturated steam temperature (standard type-S thermostat) .

Thermostats for 5° C type-H and 30° type-L, also available.

Capacities for cold condensate discharge at 20°C are two to three times greater.

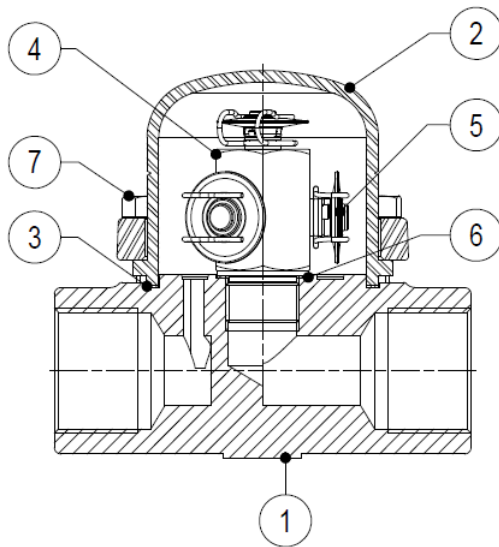
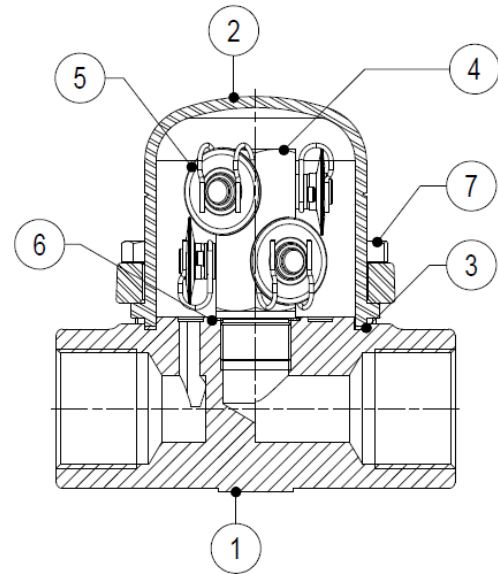
TH36/4

TH36/6

DIMENSIONS (mm)													
SIZE DN	BSP - NPT - SW - BW				EN 1092-1 PN40			ANSI 150			ANSI 300		
	A	C	D	WGT. Kgs	B	F*	WGT. Kgs	B	F*	WGT. Kgs	B	F*	WGT. Kgs
1 1/2" - 40	160	126	112	4,6	75	230	9,3	64	230	8,2	78	230	11,2
2" - 50	230	126	112	5,8	83	230	10,2	76	230	10	83	230	11,6

* Note: different face to face dimensions on request.

MATERIALS		
POS. Nr.	DESIGNATION	MATERIAL
1	Body	ASTM A105 / 1.0432 (Equiv. P250GH)
2	Cover	P265GH / 1.0425 S355 J2G3 / 1.0570
3	* Gasket	St. St./Graphite
4	* Valve seat	AISI304 / 1.4301
5	* Thermostats	Stainless steel
6	* Seat gasket	Copper
7	Bolts	Steel 8.8

* Available spare parts

