

CONDENSATE DRAIN VALVES CDV 32

DESCRIPTION

CDV32 condensate drain valve automatically drains condensate from steam systems during start-up.

A compression spring inside the governor keeps the valve open if the appliance stays without pressure.

As soon as the service pressure has reached the closing pressure to which the CDV has been adjusted, the valve closes due to the differential pressure.

When the pressure drops below the closing pressure the Condensate Drain Valve opens by spring force.

Connections are female screwed or flanged.



MAIN FEATURES

Hand purging knob for operating CDV with the system under pressure.

Built-in, easy-to-clean strainer.

USE : Saturated steam

AVAILABLE MODELS : CDV 32

SIZES : 1/ 2", 3/ 4" - DN15 and DN20.

CONNECTION: Female screwed ISO 7/1 Rp (BS21)
Flanged EN 1092-1PN40 or ANSI
Special flanges upon request.

INSTALLATION: Vertical installation recommended.
When installed in horizontal lines, an outlet connecting pipe pointing downwards should be provided.
See IMI installation and maintenance instructions.

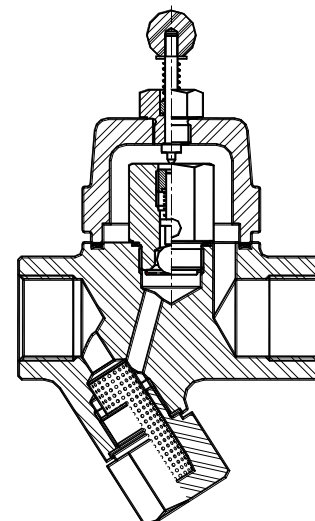

BODY LIMITING CONDITIONS		
FLANGED PN40 / ANSI 300 *	FLANGED ANSI 150 **	RELATED TEMP.
ALLOW. PRES.	ALLOW. PRES.	
40 bar	19,3 bar	50 °C
35 bar	15,8 bar	150 °C
30,4 bar	12,1 bar	250 °C
27,6 bar	10,2 bar	300 °C

Closing pressure 1,5 bar

PMO - Max. operating pressure 22 bar

TMO - Max. operating temperature 250 °C

* According to EN1092-1:2007 ; ** Acc. to EN1759-1:2004

Body limiting conditions PN40 or below, depending on the type of connection adopted. Rating PN40 for thread, SW and BW.

FLOW RATE CAPACITY IN Kgs/h										
MODEL	SIZE	DIFFERENTIAL PRESSURE (bar)								
		0,1	0,2	0,3	0,4	0,5	0,6	0,8	1	1,5
CDV 32	15 - 20	220	280	380	420	470	520	585	630	780

DIMENSIONS (mm)											
Screwed and SW*						EN PN16/PN40		ANSI 150		ANSI 300	
SIZE DN	A	B	C	D	WGT. Kgs	E	WGT. Kgs	E	WGT. Kgs	E	WGT. Kgs
15-1/2"	95	65	95	97	1,6	150	3,2	150	2,7	150	3,5
20-3/4"	95	65	95	97	1,6	150	3,9	150	3,1	150	4,7

* BW (butt weld) on request.

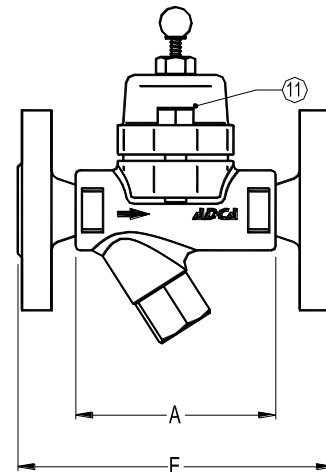

MATERIALS		
POS.N r.	DESIGNATION	MATERIAL
1	Body	P250GH / 1.0460
2	Cover	P250GH / 1.0460
3	* Gasket	St.St./Graphite
4	* Valve controller	AISI304 / 1.4301
5	*Hand purging knob	Plastic
6	* Strainer screen	AISI304 / 1.4301
7	* Gasket	St.Steel / Graphite
8	Cover strainer	A 105 / 1.0432
9	*Gasket	AISI304 / 1.4301
10	*Gasket	AISI304 / 1.4301
11	Bolts	Steel 8.8

* Available spare parts

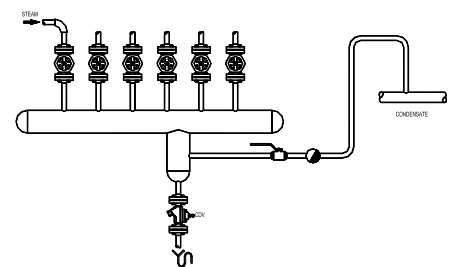
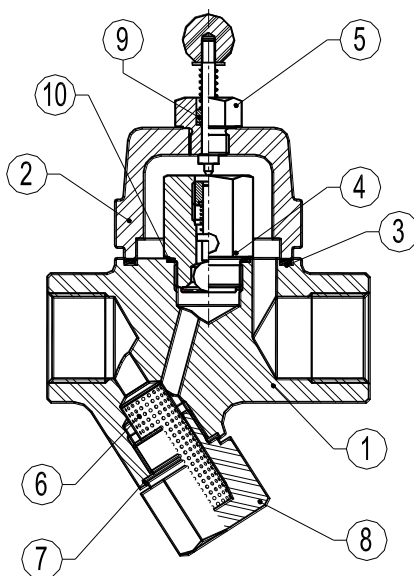
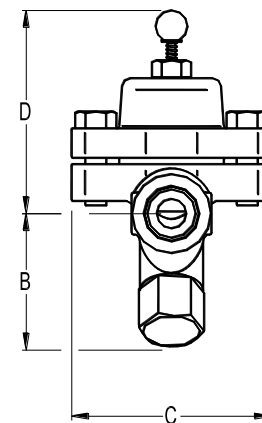

Draining a steam main with an elevated condensate line.

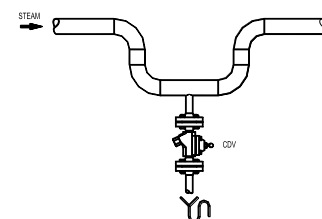

Draining a water pocket in outdoor plants, this installation also prevents freezing.