

ZIPSON'S 305F, 3-piece high performance flanged ball valve is designed for the high pressure industrial & chemical pipe line in full port usage.

Two different pressure rating & flange connection on Class 600 (1440 psi) or Class 900 (2160 psi) are both for option. Stainless steel, carbon steel or even special alloy of Hastelloy C, Alloy 20, 254 SMO, Duplex, Super Duplex for chlorine contained media, sea water, acid or alkali media are for option as required.

305F is with very smart sealing design on stem part. Self adjusting stem packing with belleville washer, TFM thrust washer with PEEK washer protector will lead to long term operation without leakage.

To compare the economic valve in the market, Zipson make valve structure & wall thickness totally with ASME B16.34 standard. The exact structure make safe in the high performance application.

Super Teflon/ TFM1600 are the standard soft material and suitable for 2160 psi pressure rating from 1/2" to 2". For 2-1/2" to 4", 2160 psi rating, seat was required to be DELRIN (POM) for ambient temperature or PEEK for high temperature.

305F valves are with complete size range from 1/2" to 4" in full port (DN15-DN100). V-ball for ball-type control valve are available for 15°, 30°, 60°, or 90° and slot ball for different flow rate requirement.

305F, the high pressure 3-piece flanged ball valve can be with fire safe design with SS seat housing & graphite stem packing / gasket for option to follow API607 fire safe standard.

The standard bare stem type is well designed with ISO 5211 direct mounting pad. ZIPSON also offer pneumatic/ electric actuator, limit switch box/ solenoid valve/ modulating controller, gear operator for complete automation service.

### SPECIFICATION

- \* Body & end caps quality investment casting
- \* Valve construction & thickness follow ANSIB16.34
- \* Full port design
- \* with ISO 5211 direct mounting pad
- \* Adjustable stem packing
- \* Available in stainless steel or carbon steel
- \* Blow-out proof stem design
- \* 100% air tested under water at 80-100 psi
- \* End type: Class 600 & Class 900
- \* Working pressure:
  - TFM seat: 1/2"~2", Class 900 (2160 psi)
  - DELFIN/ PEEK seat: 2-1/2"~4", Class 900
- \* Temperature range: see Pressure/Temperature table
- \* with locking function

### OPTION

- \* **FIRE SAFE: API607-6th Edition Certified**
- \* Spring return handle (dead man handle)
- \* Steam jacket
- \* V-ball for control valve (ball valve type)
- \* Automation application
- \* Cryogenic bonnet
- \* Fugitive emission bonnet
- \* PTFE/ PFA coating (40-70 um)
- \* Alloy: Hastalloy C/ Super duplex/ Alloy 20/ Monel

### STEM DESIGN

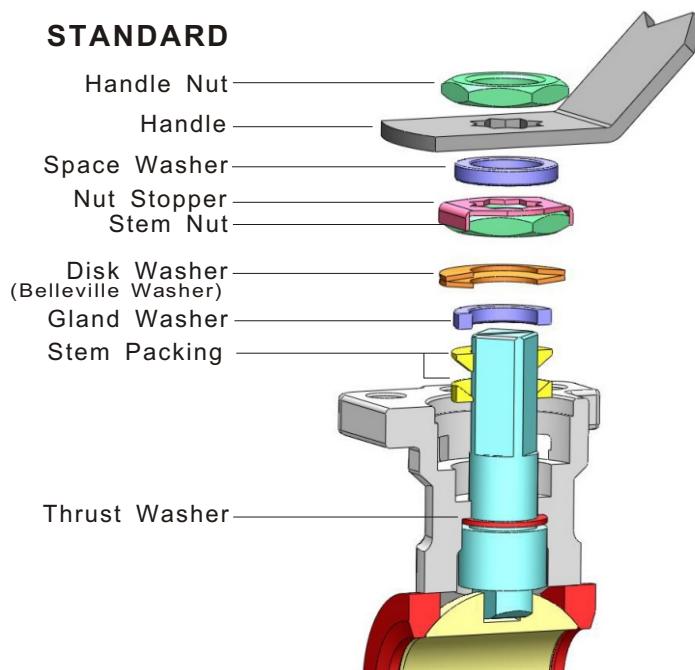

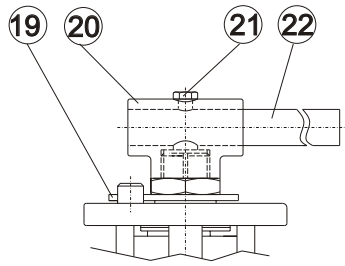

SIZE: 2" Only

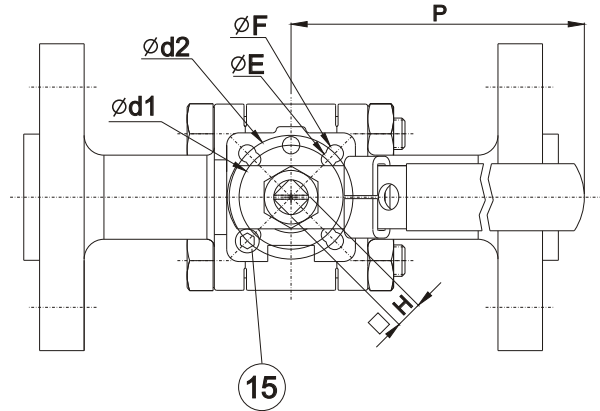

## MATERIALS LIST

ITEM	PART NAME	MATERIALS
1	BODY	CF8M
2	FLANG CAP	CF8M
3	GASKET	TFM
4	BALL	SS 316
5	BALL SEATS	TFM
6	BOLTS	SS 304
7A	THRUST WASHER	TFM
7B	THRUST WASHER	PEEK
8	STEM	SS 316
9	STEM PACKING	TFM
10	GLAND WASHER	SS 304
11	DISK WASHER	SS 301
12	GLAND NUT	SS 304
13	NUT STOP	SS 304
14	SPACE WASHER	SS 304
15	STOP PIN	SS 304
16	HANDLE NUT	SS 304
17	HANDLE	SS 304
18	HANDLE COVER	PLASTIC
19	PLATER	SS 304
20	LEVER HEAD	SS 304
21	BOLTS	SS 304
22	LEVER	STEEL PIPE

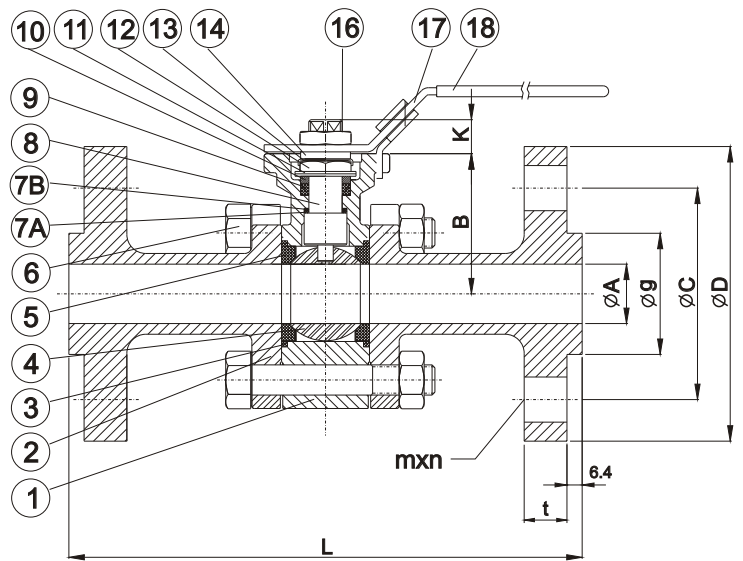

## DIMENSIONS (mm) / ASME600 (1/2" to 2")

SIZE	A	B	K	d1	d2	E	F	H	P	L	g	C	D	t	m	n
1/2"	15	48	9.5	36	42	6.0	6.0	9	130	165	35	66.7	95	14.3	15.9	4
3/4"	20	53	12	42	50	6.0	6.0	11	155	190	43	82.6	115	15.9	19.1	4
1"	25	59	12	42	50	6.0	7.0	11	155	216	51	88.9	125	17.5	19.1	4
1-1/4"	32	62	16	50	70	7.0	9.2	14	205	229	64	98.4	135	20.7	19.1	4
1-1/2"	38	70	16	50	70	7.0	9.2	14	205	241	73	114.3	155	22.3	22.3	4
2"	50	90	19	70	102	9.2	11.4	17	300	292	93	127.0	165	25.4	19.1	8

## DIMENSIONS (mm) / ASME900 (1/2" to 2")

SIZE	A	B	K	d1	d2	E	F	H	P	L	g	C	D	t	m	n
1/2"	15	48	9.5	36	42	6.0	6.0	9	130	216	35	82.6	120	22.3	22.2	4
3/4"	20	53	12	42	50	6.0	6.0	11	155	229	43	88.9	130	25.4	22.2	4
1"	25	59	12	42	50	6.0	7.0	11	155	254	51	101.6	150	28.6	25.4	4
1-1/4"	32	62	16	50	70	7.0	9.2	14	205	279	64	111.1	160	28.6	25.4	4
1-1/2"	38	70	16	50	70	7.0	9.2	14	205	305	73	123.8	180	31.8	28.6	4
2"	50	90	19	70	102	9.2	11.4	17	300	368	93	165.1	215	38.1	25.4	8

## MATERIALS LIST

ITEM	PART NAME	MATERIALS
1	BODY	CF8M
2	FLANG CAP	CF8M
3	BALL SEATS	TFM
4	BALL	SS 316
5	GASKET	TFM
6	SECONDLY GASKET (4" ONLY)	TFM
7A	THRUST WASHER	TFM
7B	THRUST WASHER	PEEK
8	STEM	SS 316
9	STEM PACKING	TFM
10	GLAND WASHER	SS 304
11	DISK WASHER	SS 301
12	GLAND NUT	SS 304
13	NUT STOP	SS 304
14	SPACE WASHER	SS 304
15	PLATER	SS 304
16	STOP PIN	SS 304
17	LEVER HEAD	SS 304
18	BOLTS	SS 304
19	LEVER	STEEL PIPE

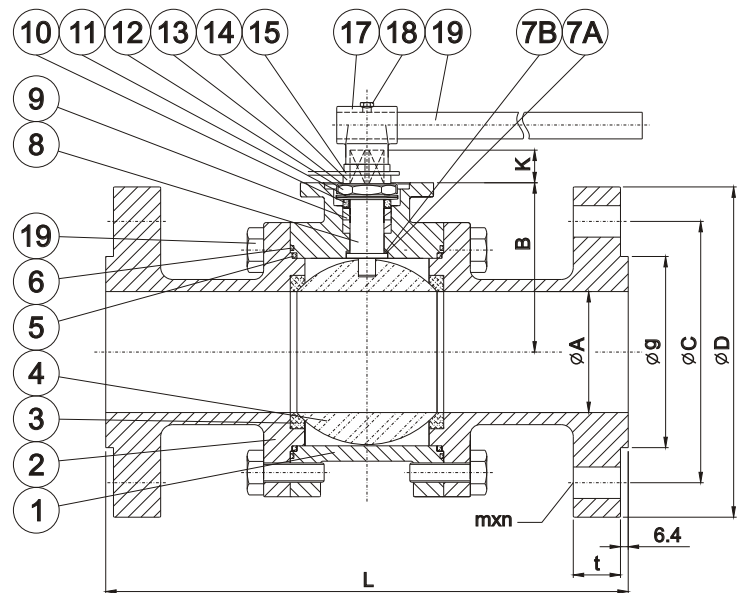
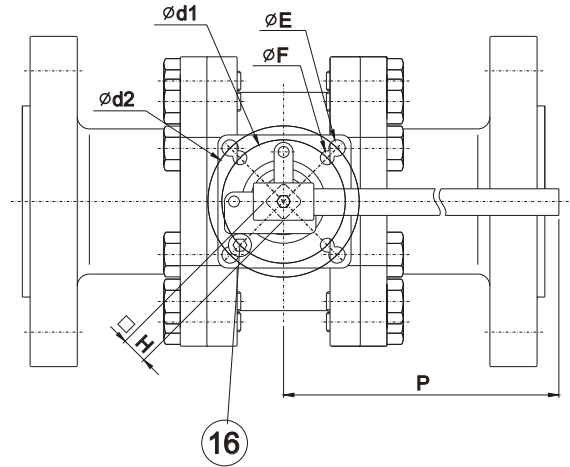

## MAX. OPERATING PRESSURE

Body Rating (Non-Shock)

VALVE SIZE	MAX. PRESSURE RATING
1/4"~1/2"	UP TO 5000 psi
3/4" & 1"	UP TO 4500 psi
1-1/4" & 1-1/2"	UP TO 4000 psi
2"	UP TO 3000 psi

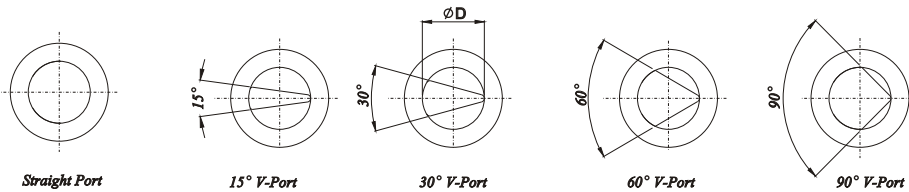

## DIMENSIONS (mm) / ASME600 (2-1/2" to 4")

SIZE	A	B	K	d1	d2	E	F	H	P	L	g	C	D	t	m	n
2-1/2"	63.5	105	19	70	102	11.4	9.2	17	350	330	105	149.2	190	28.6	23	8
3"	78	119	23	102	125	13.5	11.4	22	350	356	127	168.3	210	31.8	23	8
4"	100	140	23	102	125	13.5	11.4	22	500	432	158	216	275	38.1	26	8

## DIMENSIONS (mm) / ASME900 (2-1/2" to 4")

SIZE	A	B	K	d1	d2	E	F	H	P	L	g	C	D	t	m	n
2-1/2"	63.5	105	19	70	102	11.4	9.2	17	350	419	105	190.5	245	41.3	29	8
3"	78	119	23	102	125	13.5	11.4	22	350	381	127	190.5	240	38.1	26	8
4"	100	140	23	102	125	13.5	11.4	22	500	457	158	235	290	44.5	32	8

## PRESSURE/ TEMPERATURE

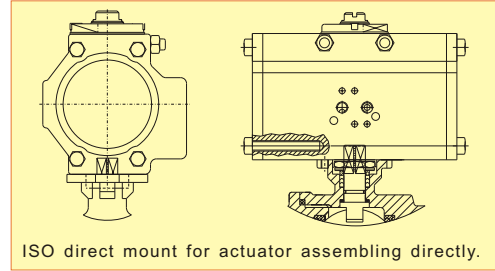
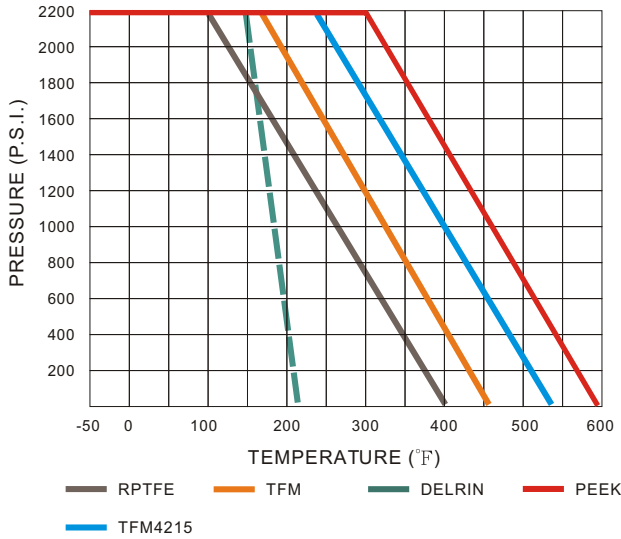

## BREAK-TORQUE VALUE (Nm/ at 2000 psi)

SIZE	1/4"	3/8"	1/2"	3/4"	1"	1 1/4"	1 1/2"	2"	2-1/2"	3"	4"
SEAT	TFM	TFM	TFM	TFM	TFM	TFM	TFM	TFM	DELIN	DELIN	DELIN
GREASE	8	8	12	15	18	25	47	83	165	250	380

Note 1: The greases ZIPSON use including lubricant & anti-seize grease are both SILICONE-FREE.

Note 2: Strongly suggest increasing at least 30%~40% for safety factor for mounting actuator.

**Zipson**  
Manufacturer of Valves

**Zipson**  
Manufacturer of Valves

### VALVE HANDLE WITH LIMIT SWITCH BOX

ZIPSON ball valve with ISO 5211 mounting pad can be with compact design for valve handle & limit switch box.

Available Type: 201D/ 302F/ 305D/ 306D/ 305F/ 306F/ 207S/ 207F/ 107S

### Suggestion!

1. As dismantle the ball valve, don't forget to replace new Repair Kits, especially the gasket to prevent from leaking.
2. PTFE is better than RPTFE (+15% Glass) as operate the valve by actuator, for Glass fiber will hurt the ball and cause the torque value increasing after over 500 times operation. Another good option is TFM or PTFE+25% Carbon.
3. Before welding the valves, make sure the ends were dismantled. And welding the dismantled ends. After all the ends be cool, assemble the ends & use new gasket to prevent from leaking.