

Gate Valves



◆ CAST STEEL GATE VALVE DESIGN STRUCTURE AND FEATURE

Design and manufacture conform to API 600, API 6D & ASME B 16.34 Test and check conform to API 598.

◆ ADOPT THE FOLLOWING STRUCTURE

Full bore

Flexible or rigid disc or soft seal structure

Self-centering gland or plate Renewable seat

Bolted bonnet, spiral wound eight-square gasket

sealing bonnet or pressure seal bonnet



◆ ACCORDING TO THE FOLLOWING STANDARD

Flange ends conform to ASME B 16.5 & ASME B 16.47A

Butt-welding end conform to ASME B 16.25

Face to face dimension conform to ASME B 16.10, API 600, API 6D

Operation type: electrical, pneumatic, hydraulic and gear etc

Gate Valve



**Z40 H
Y TYPE**

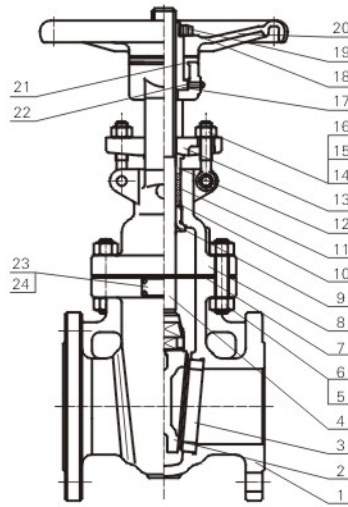

MAIN PARTS MATERIAL SHEET

Item	Part name	WCB	C5	WC6	CF8	CF8M
1	Body	A216 WCB	A217 C5	A217 WC6	A351 CF8	A351 CF8M
2	Wedge disc	A216 WCB/STL.6	A217 C5/STL.6	A217 WC6/STL.6	A351 CF8	A351 CF8M
3	Seat	A105/STL.6	A182 F11/STL.6	A182 F11/STL.6	A182 F304/STL.6	A182F 316/STL 6
4	Stem	A182 F6a	A182 F6a	A182 F6a	A182 304	A479 316
5	Bolt	A193 B7	A193 B7	A193 B7	A193 B8	A193 B8M
6	Nut	A194 2H	A194 2H	A194 2H	A194 8	A194 8M
7	Gasket 150Lb	304+flexible graphite				316+flexible graphite
	Gasket 300Lb	304+flexible graphite				Spiral wound
	Gasket ≥600Lb	F304				Spiral wound
8	Bonnet	A216 WCB	A217 C5	A217 WC6	A351 CF8	A351 CF8M
9	Backseat	A182 F6a	A182 F6a	A182 F6a	A182 F6a	A182 F316
10	Packing	304+flexible graphite				Pillar 6610+6528
11	Distance Ring	A182 F6a	A182 F6a	A182 F6a	A182 F304	A182 F316
12	Packing gland	A182 F6a	A182 F6a	A182 F6a	A182 F304	A182 F316
13	Packing plate	A216 WCB	A216 WCB	A216 WCB	A351 CF8	A351 CF8
14	Eye bolt	A193 B7	A193 B7	A193 B7	A193 B8	A193 B8
15	Nut	A194 2H	A194 2H	A194 2H	A194 8	A194 8
16	Pin	1035	1035	1035	304	304
17	Stem nut	A439 Type D2	A439 Type D2	A439 Type D2	A439 Type D2	A439 Type D2
18	Locking nut	1035	1035	1035	1035	1035
19	Locking screw	1035	1035	1035	1035	1035
20	Hand wheel	AISI 1118	AISI 1118	AISI 1118	AISI 1118	AISI 1118
21	Bearing gland	1035	1035	1035	1035	1035
22	Oil cap	Finished product	Finished product	Finished product	Finished product	Finished product
23	Nameplate	AISI 304	AISI 304	AISI 304	AISI 304	AISI 304
24	Rivet	AL	AL	AL	AL	AL

Note: the distance ring should be installed if user require

Gate Valves

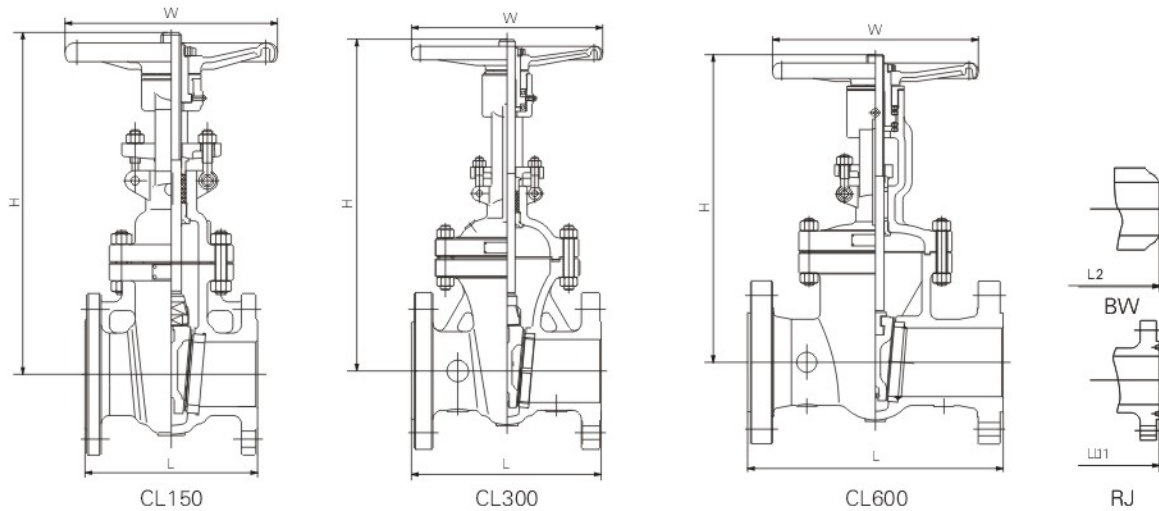

CL150

Spec (NPS)	in	2	2 1/2	3	4	5	6	8	10	12	14	16	18	20	24	28	30	32	36	40	42	48	60	
L		178	190	203	229	254	267	292	330	356	381	406	432	457	508	610	610	660	711	762	787	914	1067	
Face to face(mm)	L1	191	203	216	241	267	279	305	343	368	394	419	445	470	521	-	-	-	-	-	-	-	-	-
	L2	216	241	283	305	381	403	419	457	502	572	610	660	711	813	914	914	965	1060	1067	1118	-	-	-
Center height(mm)	H	341	371	402	472	530	587	743	904	1047	1172	1297	1433	1590	1898	2050	2330	2533	2800	-	-	-	-	-
Hand wheel diameter(mm)	W	200	200	250	280	300	300	350	400	450	500	600	680	750	800	-	-	-	-	-	-	-	-	-
Weight (Kg)		20	30	33	49	60	75	120	205	290	400	511	650	789	1200	1800	2560	3060	3500	-	-	-	-	-

CL300

Spec (NPS)	in	2	2 1/2	3	4	5	6	8	10	12	14	16	18	20	24	28	30	32	36
L		216	241	283	305	381	403	419	457	502	762	838	914	991	1143	1346	1397	1524	1727
Face to face(mm)	L1	232	257	298	321	397	419	435	473	518	778	854	930	1010	1165	1371	1422	1552	1755
	L2	216	241	283	305	381	403	419	457	502	762	838	914	991	1143	1346	1397	1524	1727
Center height(mm)	H	345	376	407	478	535	618	765	929	1094	1188	1329	1455	1860	2030	-	-	-	-
Hand wheel diameter(mm)	W	200	200	250	300	300	350	400	450	500	550	680	750	920	-	-	-	-	-
Weight (Kg)		24	36	47	69	89	123	196	333	440	710	950	1405	1720	2770	3312	4100	5200	6700

CL600

Spec (NPS)	in	2	2 1/2	3	4	5	6	8	10	12	14	16	18	20	24	28	30	32	36
L		292	330	356	432	508	559	660	787	838	889	991	1092	1194	1397	1549	1651	1778	2083
Face to face(mm)	L1	295	333	359	435	511	562	664	791	841	892	994	1095	1200	1407	1562	1664	1794	2096
	L2	292	330	356	432	508	559	660	787	838	889	991	1092	1194	1397	1549	1651	1778	2083
Center height(mm)	H	377	443	465	525	610	672	820	983	1120	1283	1429	1572	1757	1985	2230	2475	2300	2950
Hand wheel diameter(mm)	W	200	250	280	300	400	450	500	680	750	700	-	-	-	-	-	-	-	-
Weight (Kg)		39	52	88	114	-	285	413	650	800	1140	1700	2268	2850	3500	-	-	-	-

Gate Valve

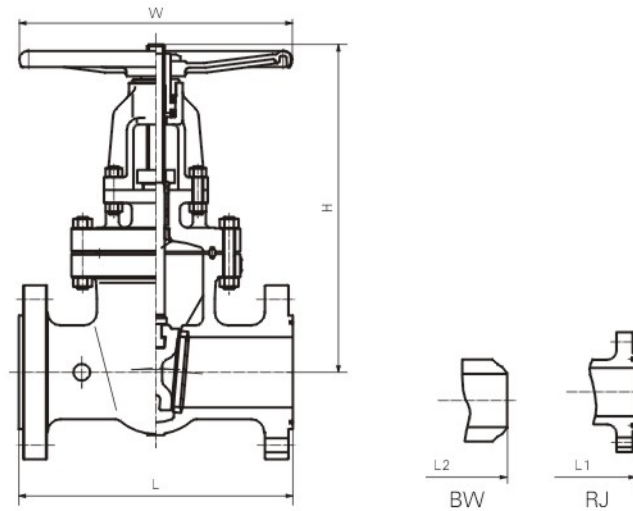

CL900

Spec (NPS)	in	2	2 1/2	3	4	5	6	8	10	12	14	16	18	20	24
Face to face(mm)	L	368	419	381	457	559	610	737	838	965	1029	1130	1219	1321	1549
	L1	371	422	384	460	562	613	740	841	968	1039	1140	1232	1334	1568
	L2	368	419	381	457	559	610	737	838	965	1029	1130	1219	1321	1549
Center height(mm)	H	445	480	513	613	730	834	875	1040	1150	1360	1520	1830	2100	2610
Hand wheel diameter(mm)	W	300	300	350	400	500	600	600	650	700	-	-	-	-	-
Weight (Kg)		72	101	130	197	285	404	650	1376	1177	1500	1920	-	-	-

CL1500

Spec (NPS)	in	2	2 1/2	3	4	5	6	8	10	12	14	16	18	20	24
Face to face(mm)	L	368	419	470	546	673	705	832	991	1130	1257	1384	1537	1664	1943
	L1	371	422	473	549	676	711	842	1001	1146	1276	1406	1559	1686	1971
	L2	368	419	470	546	673	705	832	911	1130	1257	1384	1537	1664	1943
Center height(mm)	H	462	512	550	752	927	1120	1390	1524	1850	2180	2210	-	-	-
Hand wheel diameter(mm)	W	300	350	400	550	550	600	700	800	-	-	-	-	-	-
Weight (Kg)		85	130	170	304	-	646	1100	1600	2106	2700	3500	-	-	-

CL2500

Spec (NPS)	in	2	2 1/2	3	4	5	6	8	10	12	14	16	18	20	24
Face to face(mm)	L	451	508	578	673	794	914	1022	1270	1422					
	L1	454	514	584	683	807	927	1038	1292	1444					
	L2	451	508	578	673	794	914	1022	1270	1422					
Center height(mm)	H	520	630	730	880	1020	1120	1350	1600	1900					
Hand wheel diameter(mm)	W	300	350	400	500	600	700	800	-	-					
Weight (Kg)		-	-	-	-	-	-	-	-	-					

Gate Valves



PZ⁵₉ 41Y TYPE

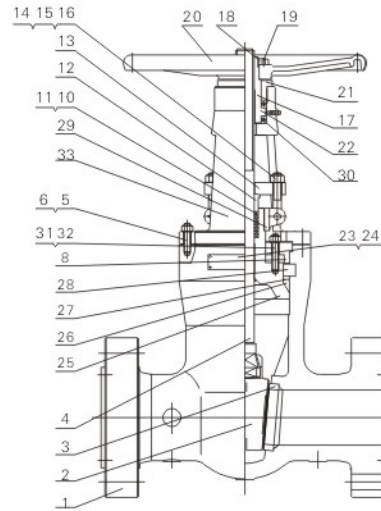

MAIN PARTS MATERIAL SHEET

Item	Part name	WCB	C5	WC6	CF8	CF8M
1	Body	A216 WCB	A217 C5	A217 WC6	A351 CF8	A351 CF8M
2	Wedge disc	A216 WCB/STL.6	A217 C5/STL.6	A217 WC6/STL.6	A351 CF8	A351 CF8M
3	Seat	A105/STL.6	A182 F11/STL.6	182 F11/STL.6	A182 F304	A182 F316
4	Stem	A182 F6a	A182 F6a	A182 F6a	A182 F304	A182 F316
5	Bolt	A193 B7	A193 B7	A193 B7	A193 B8	A193 B8M
6	Nut	A194 2H	A194 2H	A194 2H	A194 8	A194 8M
8	Bonnet	A216 WCB	A216 WCB	A216 WCB	A351 CF8	A351 CF8
10	Packing	304+flexible graphite				Pillar 6610+6528
11	Distance ring	A182 F6a	A182 F6a	A182 F6a	A182 F304	A182 F316
12	Packing gland	A182 F6a	A182 F6a	A182 F6a	A182 F304	A182 F316
13	Packing plate	A216 WCB	A216 WCB	A216 WCB	A351 CF8	A351 CF8
14	Eye bolt	A193 B7	A193 B7	A193 B7	A193 B8	A193 B8
15	Nut	A194 2H	A194 2H	A194 2H	A194 8	A194 8
16	Pin	1035	1035	1035	304	304
17	Stem bolt	A439 Type D2	A439 Type D2	A439 Type D2	A439 Type D2	A439 Type D2
18	Locking nut	1035	1035	1035	1035	1035
19	Locking screw	1035	1035	1035	1035	1035
20	Hand wheel	AISI 1118	AISI 1118	AISI 1118	AISI 1118	AISI 1118
21	Bearing gland	1035	1035	1035	1035	1035
22	Oil cup	Finished product	Finished product	Finished product	Finished product	Finished product
23	Nameplate	AISI 304	AISI 304	AISI 304	AISI 304	AISI 304
24	Rivet	AL	AL	AL	AL	AL
25	Pressure seal seat	A216 WCB	A217 C5	A217 WC6	A351 CF8	A351 CF8M
26	Pressure seal gasket	304+flexible graphite				
27	Pressure seal ring	A182 F6a	A182 F6a	A182 F6a	A182 F304	A182 F316
28	Segment ring	A182 F6a	A182 F11	A182 F11	A182 F304	A182 F316
29	Hanger Roke	A216 WCB	A216 WCB	A216 WCB	A351 CF8	A351 CF8
30	Bearing	40Cr	40Cr	40Cr	40Cr	40Cr
31	Hanger bolt	A193 B7	A193 B7	A193 B7	A193 B8	A193 B8M
32	Nut	A194 2H	A194 2H	A194 2H	A194 8	A194 8M
33	Roke	A216 WCB	A216 WCB	A216 WCB	A351 CF8	A351 CF8

Note: the distance ring should be installed if user require

Gate Valve

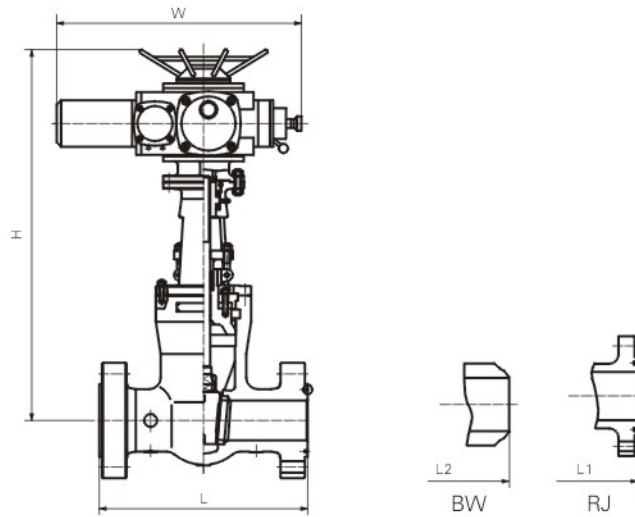

CL900

Spec (NPS)	in	2	2 1/2	3	4	6	8	10	12	14	16
Face to face(mm)	L	368	419	381	457	610	737	838	965	1029	1130
	L1	371	422	384	460	613	740	841	968	1039	1140
	L2	216	254	305	356	508	660	787	914	991	1092
Center height(mm)	H	445	252	660	666	928	-	-	-	-	-
Hand wheel diameter(mm)	W	300	300	350	400	600	-	-	-	-	1960
Weight (Kg)		50	74	90	110	195	505	745	1060	1410	-

CL1500

Spec (NPS)	in	2	2 1/2	3	4	6	8	10	12	14	16
Face to face(mm)	L	368	419	470	546	705	832	991	1130	1257	1384
	L1	371	422	473	549	711	842	1001	1146	1276	1406
	L2	216	254	305	406	559	711	864	991	1067	1104
Center height(mm)	H	485	554	672	768	-	-	-	-	-	-
Hand wheel diameter(mm)	W	300	350	400	560	-	-	-	-	-	-
Weight (Kg)		50	74	90	158	350	690	1030	1460	1810	2760

CL2500

Spec (NPS)	in	2	2 1/2	3	4	6	8	10	12	14	16
Face to face(mm)	L	451	508	578	673	914	1022	1270	1422		
	L1	454	514	584	683	927	1038	1292	1444		
	L2	279	330	368	457	610	762	914	1041		
Center height(mm)	H	594	753	840	880	-	-	-	-		
Hand wheel diameter(mm)	W	350	400	560	600	-	-	-	-		
Weight (Kg)		60	100	110	200	530	750	1610	3010		