

Forged steel gate valves

BTL valves are available in three bonnet designs. The first design is the Bolted Bonnet, with male–female joint, spiral wound gasket, made in F304L/graphite. Ring joint gasket are also available on request. The second design is the welded bonnet, with a threaded and seal welded joint. On request a full penetration strength welded joint is available, The third design is the pressure seal bonnet, with a threaded and pressure seal bonnet joint.

Construction is as follows

- ※ Full port or conventional port;
- ※ Outside screw and yoke (OS & Y);
- ※ Two piece self-aligning packing gland;
- ※ Bolted bonnet & spiral wound gasket seal bonnet;
- ※ Bolted bonnet with spiral-wound gasket, threaded and seal welded bonnet or threaded and pressure seal bonnet;
- ※ Integral backseat;
- ※ Socket weld ends to ASME B16.11;
- ※ Screwed ends (NPT) to ANSI/ASME B1.20.1.



Female threaded and socket welded gate valves

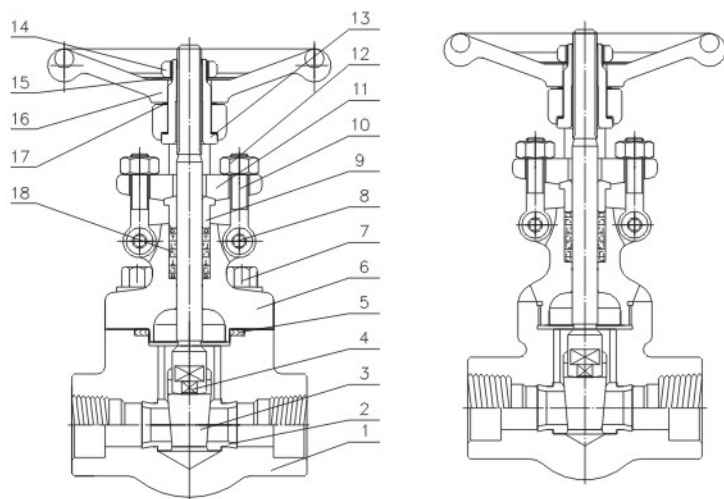

Application standards

- 1、 Design and manufacture conform to API 602、 BS5352、 ANSI B16.34;
- 2、 Connection ends conform to:
 - 1)Socket welded dimension conform to ANSI B16.11;JB/T1751
 - 2)Screw ends dimension conform to ANSI B1.20.1;JB/T7306
 - 3)Butt-welded conform to ANSI B16.25;JB/T12224
 - 4)Flanged ends conform to ANSI B16.5;JB79
- 3、 Test and inspection conform to: API 598; GB/T13927; JB/T9092
- 4、 Structure features:
 - Bolted bonnet, outside screw and yoke
 - Welded bonnet, outside screw and yoke
- 5、 Materials conform to ANIS/ASTM.
- 6、 Main materials: A105; LF2; F5; F11; F22; 304(L); 316(L); F347; F321; F51; Monel; 20 Alloy.

Carbon steel temperature–pressure rate

CL150–285 P.S.I @ 100° F
 CL300–740 P.S.I @ 100° F
 CL600–1480 P.S.I @ 100° F
 CL800–1975 P.S.I @ 100° F
 CL1500–3705 P.S.I @ 100° F

Main part materials list

NO.	Part name	A105/F6a	A105/F6aHFS	LF2/304	F11/F6aHF	F304(L)/304(L)	F316(L)/316(L)	F51/F51
1	Body	A105	A105	LF2	F11	F304(L)	F316(L)	F51
2	Seat	410	410HF	304	410HF	304(L)	316(L)	F51
3	Wedge	F6a	F6a	F304	F6aHF	F304(L)	F316(L)	F51
4	Stem	F6a	F6a	F304	F6a	F304(L)	F316(L)	F51
5	Gasket	304+ Flexible graphite	304+ Flexible graphite	304+ Flexible graphite	304+ Flexible graphite	304+ Flexible graphite	316+ Flexible graphite	316+ Flexible graphite
6	Bonnet	A105	A105	LF2	F11	F304(L)	F316(L)	F51
7	Bolt	B7	B7	L7	B16	B8(M)	B8(M)	B8M
8	Pin	410	410	410	410	304	304	304
9	Gland	410	410	304	410	304	316	F51
10	Gland eyebolt	B7	B7	L7	B16	B8(M)	B8(M)	B8M
11	Gland flange	A105	A105	LF2	F11	F304	F304	F304
12	Hex nut	2H	2H	7	4	8(M)	8(M)	8M
13	Stem nut	410	410	410	410	410	410	410
14	Locking nut	35	35	35	35	35	35	35
15	Nameplate	AL	AL	AL	AL	AL	AL	AL
16	Handwheel	A197	A197	A197	A197	A197	A197	A197
17	Lubricating gasket	410	410	410	410	410	410	410
18	Packing	Graphite	Graphite	Graphite	Graphite	Graphite	Graphite	Graphite

Female threaded and socket welded gate valves

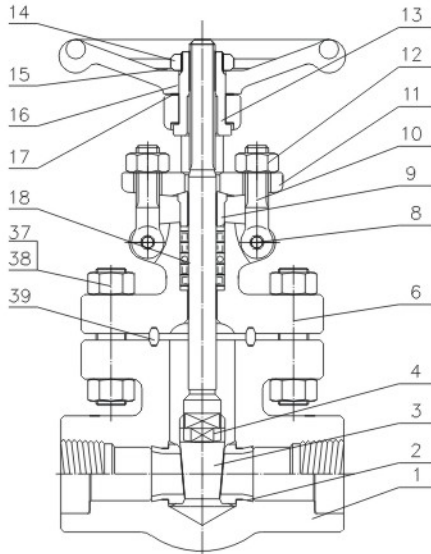

Application standards

- 1、 Design and manufacture conform to API 602、 BS5352、 ANSI B16.34;
- 2、 Connection ends conform to:
 - 1)Socket welded ends conform to ANSI B16.11;JB/T1751
 - 2)Screw ends conform to ANSI B1.20.1;JB/T7306
 - 3)Butt-welded ends conform to ANSI B16.25;JB/T12224
 - 4)Flanged ends conform to ANSI B16.5;JB79
- 3、 Test and inspection conform to: API 598; GB/T13927; JB/T9092
- 4、 Structure features:
 - Bolted bonnet, outside screw and yoke
 - Welded bonnet, outside screw and yoke
- 5、 Materials conform to ANSI/ASTM.
- 6、 Main materials:
 - A105; LF2; F5; F11; F22; 304(L); 316(L); F347; F321; F51; Monel; 20 Alloy.

Carbon steel temperature–pressure rate

CL150–285 P.S.I @ 100° F
 CL300–740 P.S.I @ 100° F
 CL600–1480 P.S.I @ 100° F
 CL800–1975 P.S.I @ 100° F
 CL1500–3705 P.S.I @ 100° F

Main part materials list

NO.	Part name	A105/F6a	A105/F6aHFS	LF2/304	F11/F6aHF	F304(L)/304(L)	F316(L)/316(L)	F51/F51
1	Body	A105	A105	LF2	F11	F304(L)	F316(L)	F51
2	Seat	410	410HF	304	410HF	304(L)	316(L)	F51
3	Wedge	F6a	F6a	F304	F6aHF	F304(L)	F316(L)	F51
4	Stem	F6a	F6a	F304	F6a	F304(L)	F316(L)	F51
6	Bonnet	A105	A105	LF2	F11	F304(L)	F316(L)	F51
8	Pin	410	410	410	410	304	304	304
9	Gland	410	410	304	410	304	316	F51
10	Gland eyebolt	B7	B7	L7	B16	B8(M)	B8(M)	B8M
11	Gland flange	A105	A105	LF2	F11	F304	F304	F304
12	Hex nut	2H	2H	7	4	8(M)	8(M)	8M
13	Stem nut	410	410	410	410	410	410	410
14	Locking nut	35	35	35	35	35	35	35
15	Nameplate	AL	AL	AL	AL	AL	AL	AL
16	Handwheel	A197	A197	A197	A197	A197	A197	A197
17	Lubricating gasket	410	410	410	410	410	410	410
18	Packing	Graphite	Graphite	Graphite	Graphite	Graphite	Graphite	Graphite
37	Screwed stud	B7	B7	L7	B16	B8(M)	B8(M)	B8(M)
38	Nut	2H	2H	7	4	8(M)	8(M)	8(M)
39	Metal ring	304	304	304	304	304(L)	316(L)	F51

Pressure sealing gate valves

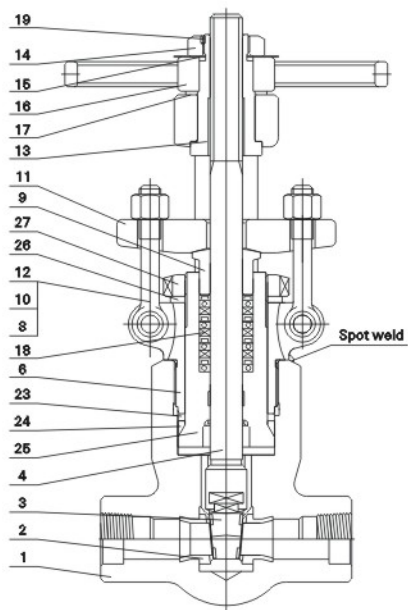

Application standards

- 1、 Design and manufacture conform to
API 602、 BS5352、 ANSI B16.34
- 2、 Connection ends conform to:
 - 1)Socket welded dimension conform to ANSI B16.11;JB/T1751
 - 2)Screw ends dimension conform to ANSI B1.20.1;JB/T7306
 - 3)Butt-welded conform to ANSI B16.25;JB/T12224
 - 4)Flanged ends conform to ANSI B16.5;JB79
- 3、 Test and inspection conform to:
API 598; GB/T13927; JB/T9092
- 4、 Structure features:
A threaded and pressure seal bonnet
- 5、 Materials conform to ANIS/ASTM.
- 6、 Main materials:
A105; LF2; F5; F11; F22; 304(L); 316(L); F347; F321;
F91; Monel; 20 Alloy.

Carbon steel temperature–pressure rate

CL1500–3705 P.S.I @ 100° F
CL2500–6170 P.S.I @ 100° F
CL4500–11110P.S.I @ 100° F

Main part materials list

NO.	Part name	A105/F6a	A105/F6aHFS	LF2/304	F11/F6aHF	F304(L)/304(L)	F316(L)/316(L)	F91/410 HF
1	Body	A105	A105	LF2	F11	F304(L)	F316(L)	F91
2	Seat	410	410HF	304	410HF	304(L)	316(L)	F91HF
3	Wedge	F6a	F6a	F304	F6aHF	F304(L)	F316(L)	F91HF
4	Stem	F6a	F6a	F304	F6a	F304(L)	F316(L)	F91
6	Bonnet	A105	A105	LF2	F11	F304(L)	F316(L)	F91
8	Pin	410	410	410	410	304	304	410
9	Gland	410	410	304	410	304	316	F91
10	Gland eyebolt	B7	B7	L7	B16	B8(M)	B8(M)	B8
11	Gland flange	A105	A105	LF2	F11	F304	F304	F91
12	Hex nut	2H	2H	7	4	8(M)	8(M)	8
13	Stem nut	410	410	410	410	410	410	410
14	Locking nut	35	35	35	35	35	35	35
15	Nameplate	AL	AL	AL	AL	AL	AL	AL
16	Handwheel	A197	A197	A197	A197	A197	A197	A190
17	Lubricating gasket	410	410	410	410	410	410	410
18	Packing	Graphite	Graphite	Graphite	Graphite	Graphite	Graphite	Graphite
19	Stop nut	35	35	35	35	35	35	35
23	Seal gasket	420	420	304	304	304(L)	316(L)	420
24	P.S.ring	304	304	304	304	304	316	316
25	P.S.seat	420	420	304	304	304(L)	316(L)	F91
26	Nut pad	410	410	410	410	410	410	410
27	Packing nut	Cast steel	Cast steel	Cast steel	Cast steel	Stainless steel	Stainless steel	Cast steel

Female threaded and socket welded gate valves

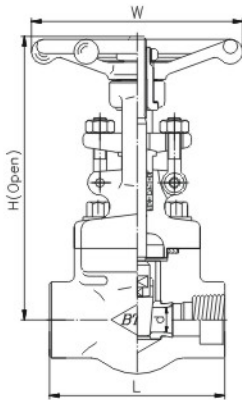

CL800

Bolted bonnet, full bore and reduced bore outside screw and yoke(OS & Y)
Threaded, butt-welded or socket welded ends; design to API 602

Specification (NPS)	R.P	-	1/2	3/4	1	1 1/4	1 1/2	2	2 1/2	3
	F.P	1/4	3/8	1/2	3/4	1	1 1/4	1 1/2	2	2 1/2
Face to face	L	73	73	80	100	114	120	130	145	180
Handwheel diameter	W	100	100	100	125	160	160	180	200	220
Height	H	144	144	150	182	216	235	270	300	370
Flow port dimension	d	9.5	9.5	13	17.5	24	29	36.5	44	51
Weight(Kg)		1.7	1.7	1.9	3.1	4.8	5.9	8.5	12.2	24

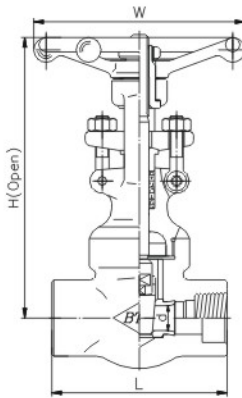

CL800

Welded bonnet, full bore and reduced bore outside screw and yoke(OS & Y)
Threaded, butt-welded or socket welded ends; design to API 602

Specification (NPS)	R.P	-	1/2	3/4	1	1 1/4	1 1/2	2	2 1/2	3
	F.P	1/4	3/8	1/2	3/4	1	1 1/4	1 1/2	2	2 1/2
Face to face	L	73	73	80	100	114	120	130	145	180
Handwheel diameter	W	100	100	100	125	160	160	180	200	220
Height	H	142	142	145	182	212	230	263	300	370
Flow port dimension	d	9.5	9.5	13	17.5	24	29	36.5	44	51
Weight(Kg)		1.4	1.4	1.6	2.6	4.5	5.4	8.4	12.1	22

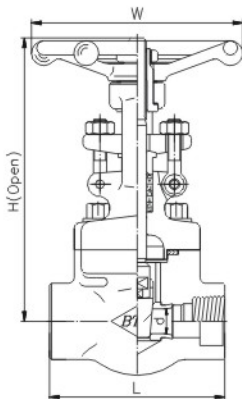

CL900-CL1500

Bolted bonnet, full bore and reduced bore outside screw and yoke(OS&Y)
Threaded, butt-welded or socket welded ends; design to API 602

Specification (NPS)	R.P	-	1/2	3/4	1	1 1/4	1 1/2	2	2 1/2	3
	F.P	1/4	3/8	1/2	3/4	1	1 1/4	1 1/2	2	2 1/2
Face to face	L	80	100	100	114	120	130	140	180	-
Handwheel diameter	W	100	125	125	160	160	180	180	220	-
Height	H	145	180	180	209	230	250	290	400	-
Flow port dimension	d	9.5	13	13	17.5	24	29	36.5	44	-
Weight(Kg)		2.4	3.4	3.4	5.1	5.4	7.6	11	22	-

Female threaded and socket welded gate valves

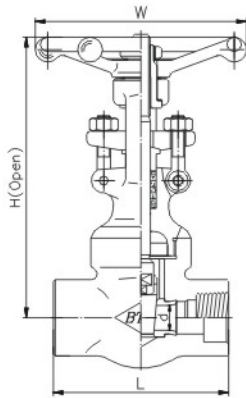

CL900-CL1500

Welded bonnet, full bore and reduced bore outside screw and yoke(OS&Y)
Threaded, butt-welded or socket welded ends; design to API 602

Specification (NPS)	R.P	-	1/2	3/4	1	1 1/4	1 1/2	2	2 1/2	3
	F.P	1/4	3/8	1/2	3/4	1	1 1/4	1 1/2	2	2 1/2
Face to face	L	80	100	100	114	120	130	140	180	-
Handwheel diameter	W	100	125	125	160	160	180	180	220	-
Height	H	147	182	182	206	225	246	282	370	-
Flow port dimension	d	9.5	13	13	17.5	24	29	36.5	45	-
Weight(Kg)		2.4	3.0	3.0	5.0	5.3	8.7	11	22.8	-

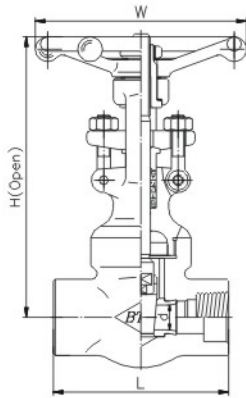

CL2500

Welded bonnet, full bore outside screw and yoke (OS & Y)
Socket welded ends, design conform to ASME B16.34

Specification(NPS)	F.P	1/4	3/8	1/2	3/4	1	1 1/4	2
Face to face	L	-	114	114	114	120	-	-
Handwheel diameter	W	-	160	160	160	160	-	-
Height	H	-	204	204	204	221	-	-
Flow port dimension	d	-	13	13	13	17.5	-	-
Weight(Kg)		-	8	8.5	8.7	8.8	-	-

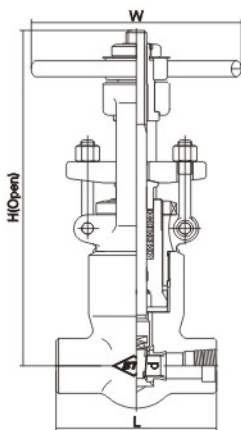

CL1500-CL2500

Pressure seal bonnet, full bore outside screw and yoke(OS & Y)
Socket welded ends, design conform to ASME B16.34

Specification(NPS)	F.P	3/8	1/2	3/4	1	1 1/4	1 1/2	2	
Face to face	L	CL900~1500	140	140	140	140	178	178	216
		CL2500	186	186	186	186	216	216	279
Handwheel diameter	W	CL900~1500	200	200	200	200	280	280	300
		CL2500	200	200	200	200	280	280	300
Height	H	CL900~1500	308	308	315	315	446	446	540
		CL2500	321	321	321	330	456	456	550
Flow port dimension		CL900~1500	13.5	13.5	18	18	29	36	40
		CL2500	13.5	13.5	18	18	29	29	36
Weight(Kg)		CL900~1500	11.5	11.5	10.8	10.5	19.6	21.0	55.2
		CL2500	12.0	12.1	11.8	11.0	26.8	21.8	60.0

Forged steel flange gate valves

CL150-300-600 Bolted bonnet, reduced bore outside screw and yoke(OS & Y) welded flange or butt-welded ends; design to API602;BS5352

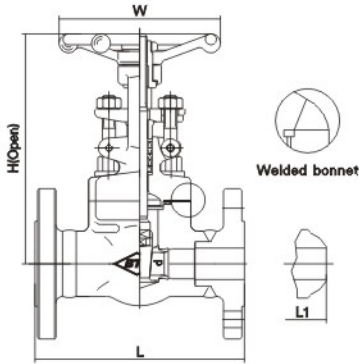

Specification(NPS)		1/4	3/8	1/2	3/4	1	1 1/4	1 1/2	2	2 1/2		
Face to face	CL150	-	-	108	117	127	140	165	178	190		
	CL300	L(RF)		-	-	140	152	165	178	190	216	241
	CL600	L1(BW)		-	-	165	190	216	229	241	292	330
Handwheel diameter		W		-	-	100	100	125	160	160	180	200
Height	CL150	H		-	-	144	150	182	216	235	270	300
	CL300,CL600	H		-	-	144	150	182	216	235	270	300
Height (angle dimension)		d		-	-	9.5	13	17.5	24	29	36.5	44
Weight (Kg)	CL150	RF	-	-	2.6	3.3	4.9	8.4	9.0	12.1	24	
		BW	-	-	2.0	3.8	4.2	7.8	8.0	12	19.2	
	CL300	RF	-	-	3.2	4.7	6.3	9.6	11.4	15.4	26.2	
		BW	-	-	2.8	4.1	5.7	8.1	9.2	13.1	23	
	CL600	RF	-	-	3.5	4.8	6.3	9.6	10.1	13.9	32	
		BW	-	-	2.9	4.0	5.7	8.1	8.9	11.8	28	

If you want to order one piece body, please contact with sales department

CL900-CL1500 Welded bonnet, full bore outside screw and yoke(OS & Y) welded flange or butt-welded ends; design to BS 5352

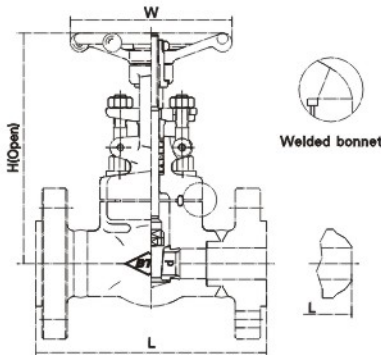

Specification(NPS)		1/4	3/8	1/2	3/4	1	1 1/4	1 1/2	2
Face to face	L(RF),L1(BW)	-	-	216	229	254	279	305	368
	L(RTJ)	-	-	216	229	254	279	305	371
Handwheel diameter	W	-	-	125	125	160	160	180	180
Height	H	-	-	180	180	209	230	250	270
Flow port dimension	d	-	-	13	13	17.5	24	29	36.5
Weight(Kg)		-	-	5.1	8.9	10.1	13.7	21.5	28.2

If you want to order one piece body, please contact with sale department

CL2500 Pressure seal gate valves, full bore outside screw and yoke(OS & Y) welded flange or butt-welded ends; design to ASME B16.34

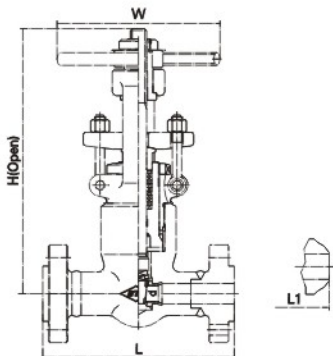

Specification(NPS)		1/4	3/8	1/2	3/4	1	1 1/4	1 1/2	2
Face to face	L(RF),L1(BW)	-	-	264	273	308	-	384	451
	L(RTJ)	-	-	264	273	308	-	387	454
Handwheel diameter	W	-	-	200	200	200	-	280	300
Height	H	-	-	321	321	330	-	456	550
Flow port dimension	d	-	-	13.5	18	18	-	29	36
Weight(Kg)		-	-	13.1	13.0	13.7	-	29.7	63.2

Chosen devices and varieties of gate valves

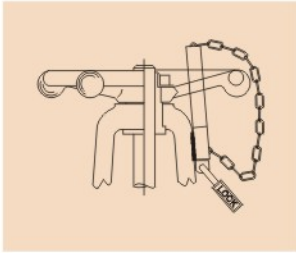

Locking device

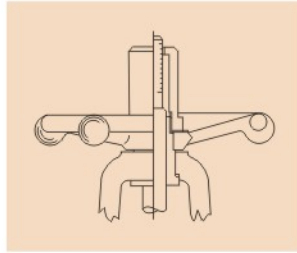

Position indicator

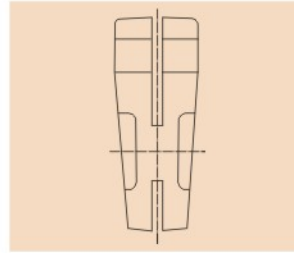

Flexible wedge

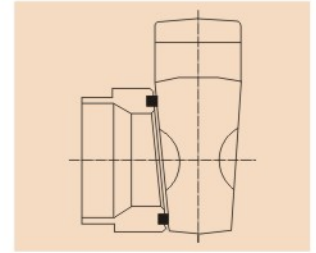

Insert PTFE seat

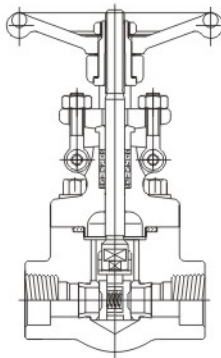

Dynamic double-wedge gate valves

	CLASS	Materials
API 6D Outside screw and yoke	600	Carbon Steel, Cryogenic Carbon Steel/ Alloy Steel, Stainless steel
	900/1500	
	2500	

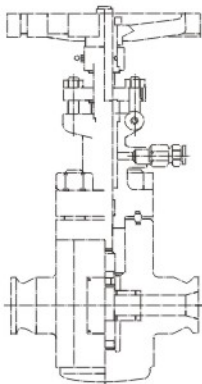

Flat gate valves

	CLASS	Materials
API 6D Outside screw and yoke	600	Carbon Steel, Cryogenic Carbon Steel/ Alloy Steel, Stainless steel
	900/1500	
	2500	

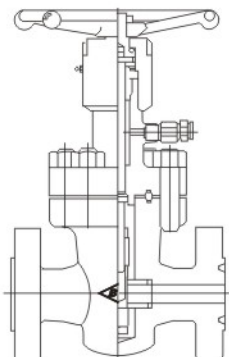

Flat gate valves

	CLASS	Materials
API 6D Outside screw and yoke	3000	Carbon Steel, Cryogenic Carbon Steel/ Alloy Steel, Stainless steel
	5000	
	10000	

Special purposes gate valves

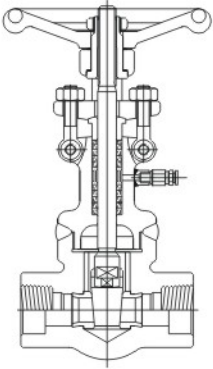

- ※Welded bonnet
- ※OS & Y
- ※Packing
- ※Distance ring
- ※Injector sealing gum valves
- ※Solid wedge

Vacuum gate valves

	Temperature- pressure rate	Body/bonnet	Materials Trim	Bolt
CLASS 800 API 602-BS 5352 Reduced bore and full bore	1975 psi @ 100° F	Cast steel	13Cr	B7

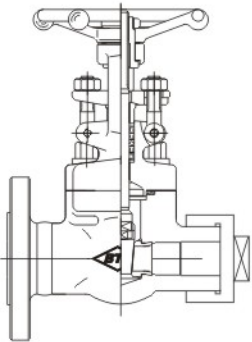

- ※Bolted
- ※OS & Y
- ※Cap fitting connection
- ※Solid wedge

For venting and/or releasing media

	Temperature- pressure rate	Body/bonnet	Materials Trim	Bolt
CLASS 800 API 602-BS 5352 Reduced port and full bore	1975 psi @ 100° F	Cast steel	13Cr	B7

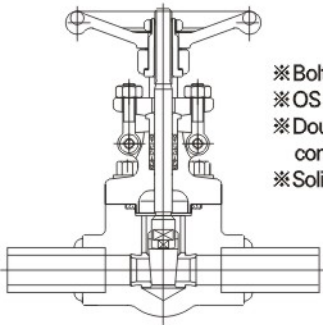

- ※Bolted bonnet
- ※OS & Y
- ※Double end pipe connection
- ※Solid wedge

Coupling pipe valves

	Temperature- pressure rate	Body/bonnet	Materials Trim	Bolt
CLASS 800 API 602-BS 5352 Reduced bore and full bore	1975 psi @ 100° F	Cast steel	13Cr	B7

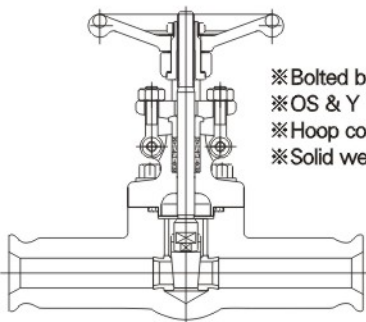

- ※Bolted bonnet
- ※OS & Y
- ※Hoop connection
- ※Solid wedge

Hoop gate valves

	Temperature- pressure rate	Body/bonnet	Materials Trim	Bolt
CLASS 800 API 602-BS 5352 Reduced bore and full bore	1975 psi @ 100° F	Cast steel	13Cr	B7