

Bellow Gate Valve

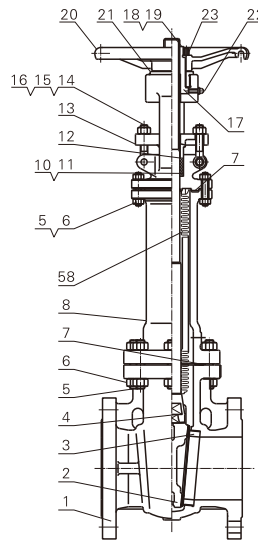

WZ40H Type



Main parts material sheet

Item	Part name	WCB	CF8	CF3	CF3M	CE3MN
1	Body	A216 WCB	A351 CF8	A351 CF3	A351 CF3M	CE3MN
2	Wedge	A216 WCB	A351 CF8	A351 CF3	A351 CF3M	CE3MN
3	Seat	A105	A182 F304	A182 F304L	A182 F316L	F53
4	Stem	A182 F6a	A182 F304	A182 F304L	A182 F316L	F53
5	Bolt	A193 B7	A193 B8	A193 B8	A193 B8M	A193 B8M
6	Nut	A194 2H	A194 8	A194 8	A194 8M	A194 8M
7	Gasket	304+flexible graphite	304+flexible graphite	304+flexible graphite	316+flexible graphite	316+flexible graphite
8	Bonnet	A216 WCB	A351 Cf8	A351 Cf3	A351 CF3M	A351 CE3MN
10	Packing	304+flexible graphite	304+flexible graphite	304+flexible graphite	316+flexible graphite	316+flexible graphite
11	Distance ring	A182 F6a	A182 F304	A182 F304	A182 F316	F53
12	Packing gland	A182 F6a	A182 F304	A182 F304	A182 F316	F53
13	Packing plate	A216 WCB	A351 CF8	A351 CF8	A351 CF8	A351 CF8
14	Eye bolt	A193 B7	A193 B8	A193 B8	A193 B8M	A193 B8M
15	Nut	A194 2H	A194 8	A194 8	A194 8M	A194 8M
16	Pin	1035	304	304	304	304
17	Stem bolt	A439 type D2	A439 type D2	A439 type D2	A439 type D2	A439 type D2
18	Locking nut	1035	1035	1035	1035	1035
19	Locking screw	1035	1035	1035	1035	1035
20	Hand wheel	Ducerle LI0m	Ducerle L10m	Ducerle L10m	Ducerle L10m	Ducerle L10m
21	Bearing gland	1035	1035	1035	1035	1035
22	Oil cup	Finished product	Finished product	Finished product	Finished product	Finished product
23	Nameplate	AL	AL	AL	AL	AL
58	Bellow	F321	F321	F321	F316L	F53

Note: the distance ring should be installed if user require

Bellow Gate Valve

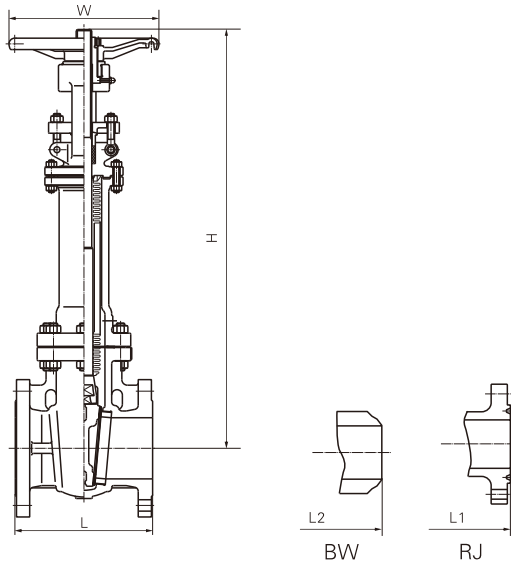

CL150

Spec (NAP)	in	2	2 1/2	3	4	5	6	8	10	12	14	16	18	20	24
Face to face(mm)	L	178	190	203	229	254	267	292	330	356	381	406	432	457	508
	L1	191	203	216	241	267	279	305	343	368	394	419	445	470	521
	L2	216	241	283	305	381	403	419	457	502	572	610	660	711	813
Center height(mm)	H	440	520	570	690	810	920	1200	1430	1650	1920	2120	2450	2700	3200
Hand wheel diameter (mm)	W	200	200	250	280	300	300	350	400	450	500	600	680	750	800
Weight (Kg)		30	50	65	80	95	122	160	260	340	500	610	780	900	1350

CL300

Spec (NAP)	in	2	2 1/2	3	4	5	6	8	10	12	14	16	18	20	24
Face to face(mm)	L	216	241	283	305	381	403	419	457	502	762	838	914	991	1143
	L1	232	257	298	321	397	419	435	473	518	778	854	930	1010	1165
	L2	216	241	283	305	381	403	419	457	502	762	838	914	991	1143
Center height(mm)	H	450	560	590	730	850	960	1250	1500	1720	2010	2250	2620	2900	3360
Hand wheel diameter (mm)	W	200	200	250	300	300	350	400	450	500	550	680	750	920	-
Weight (Kg)		35	55	70	85	100	125	175	290	365	540	650	820	930	1400

CL600

Spec (NAP)	in	2 1/2	3	4	5	6	8	10	12	14	16	18	20	24	
Face to face(mm)	L	292	330	356	432	508	559	660	787	838	889	991	1092	1194	1397
	L1	295	333	359	435	511	562	664	791	841	892	994	1095	1200	1407
	L2	292	330	356	432	508	559	660	787	838	889	991	1092	1194	1397
Center height(mm)	H	465	585	600	750	870	980	1270	1525	1750	2140	2270	2650	2930	3390
Hand wheel diameter (mm)	W	200	250	280	300	400	450	500	680	750	700	-	-	-	-
Weight (Kg)		45	65	80	95	125	135	185	310	395	575	690	850	970	1460