

Rp	Nb	DESIGNATION		MATERIAL
01	1	CORPS EN LIGNE	INLINE BODY	1.4408 CF8M
03	1	CORPS DE CAPACITE	CAPACITY BODY	1.4408 CF8M
04	1	TOURNANT SPHERIQUE	BALL	1.4404 AISI 316L
05	1	TIGE	STEM	1.4404 AISI 316L
06	1	SIEGE AMONT	INLET BALL SEAT	PTFE
07	2	INSERT	INSERT	PTFE
08	1	JOINT DE CORPS	BODY GASKET	PTFE
09	1	BAGUE DE FROTTEMENT	THRUST WASHER	PTFE
10	1	SIEGE AVAL	OUTLET BALL SEAT	PTFE
11		GARNITURE	GLAND PACKING	PTFE
12	1	RESSORT DE LIAISON	SPRING	1.4310 AISI 302
13	1	FOULOIR DE P.E	GLAND	ASTM A743 CD4 MCU
14	4	GOUJON DE CORPS	CAP BODY	A 193 gr B8
15	4	ECROU DE CORPS	CAP NUT	A 194 gr 8
16	2	VIS DE P.E	GLANG BOLT	304
17	1	BUTEE D'ARRET	STOPPER	304
18	1	LEVIER DE MANOEUVRE	HANDLE	FONTE DUCTILE
19	1	CIRCLIPS	SNAP RING	304
20	4	RONDELLE W	WASHER W	INOX STAINLESS STEEL
21	1	BAGUE DE COLLECTAGE	COLLECTING RING	PTFE
22	1	RONDELLE	WASHER	INOX STAINLESS STEEL
23	1	TUBE DE SORTIE	END TUBE	PTFE
24	1	JOINT DE SIEGE	SEAT O'RING	FPM OU/OR FFKM
25	1	EMBOUIT ADAPT. FLACON	END BOTTLE ADAPTER	PTFE-VERRE PTFE-GLASS
26	1	VIS	SCREW	INOX STAINLESS STEEL
32	1	GOUPILLE	PIN	INOX

**DESCRIPTION**

- ROBINET A TOURNANT SPHERIQUE CAPACITIF
- RACCORDEMENT A BRIDES INTEGRALES
- CAPACITE 25,50 OU 100 ml
- EMBOUIT D'ADAPTATION USINE SELON FLACON
- MATERIEL CONFORME AUX DIRECTIVES 97/23 CE & ATEN 94/9 CE

**OPTIONS**

- AUTRES DN, MATERIAUX, RACCORDEMENTS ET CAPACITES SUR DEMANDE
- FLACON AUTO-OBTURABLE
- ADAPTATION POUR MOTORISATION

**RACCORDEMENTS CONNECTIONS**

LES DIMENSIONS DES BRIDES SONT EN ACCORD AVEC LA NORME NF EN 1092-1 POUR LES BRIDES DESIGNEES PN ET AVEC LA NF EN 1759-1 POUR CELLES DESIGNEES CLASS. LES ROBINETS GN40 ET GN300 PEUVENT ETRE INSTALLEES SUR DES BRIDES PN40 ET CLASS 300 MAIS LES LIMITES D'UTILISATION SONT CELLES DU PN16

DIMENSIONS OF FLANGES ACCORDING TO NF EN 1092-1 FOR DESIGNED PN AND NF EN 1759-1 FOR FLANGES DESIGNED CLASS. THE SAMPLING VALVES GN40 AND GN300 COULD BE INSTALLED ON THE FLANGES PN40 AND CLASS 300 BUT THEIR LIMITS ARE AS THE VALVES PN16

ND	DN	PN16	GN40	CLASS150	GN300	H	MASSE Wt(Kg)
3.4"	20	✓	✓	✓	✓	150	8 Kg
1"	25	✓	✓	✓	✓	150	9 Kg
1.14"	32	✓	✓	✓	✓	150	10 Kg
1.12"	40	✓	✓	✓	✓	160	13 Kg
2"	50	✓	✓	✓	✓	160	14 Kg
3"	80	✓	✓	✓	✓	185	20 Kg
4"	100	✓	✓	✓	✓	185	35 Kg
6"	150	✓	✓	✓	✓	215	55 Kg

**DESCRIPTION**

- SAMPLING BALL VALVE WITH CAPACITY CONNECTION INTEGRAL FLANGES
- CAPACITY 25,50 OR 100 ml
- ADAPTATION LND MACHINING ACCORDING TO BOTTLE SIZE
- MATERIEL CONFORME AUX DIRECTIVES 97/23 CE & ATEN 94/9 CE

**OPTIONS**

- OTHER MATERIALS CONNECTIONS AND CAPACITY ON REQUEST
- TIGHT BOTTLE
- AUTOMOUNTING

**LIMITES PRESS./TEMP. - PRESSURE, TEMP. LIMITS**

RACCORDEMENTS CONNECTIONS	RELATION PS / TS					
	20°C	50°C	100°C	150°C	180°C	TS
PN16 / GN40						PS (bar)
CLASS 150 / GN300	16	16	14,9	13,5	11	

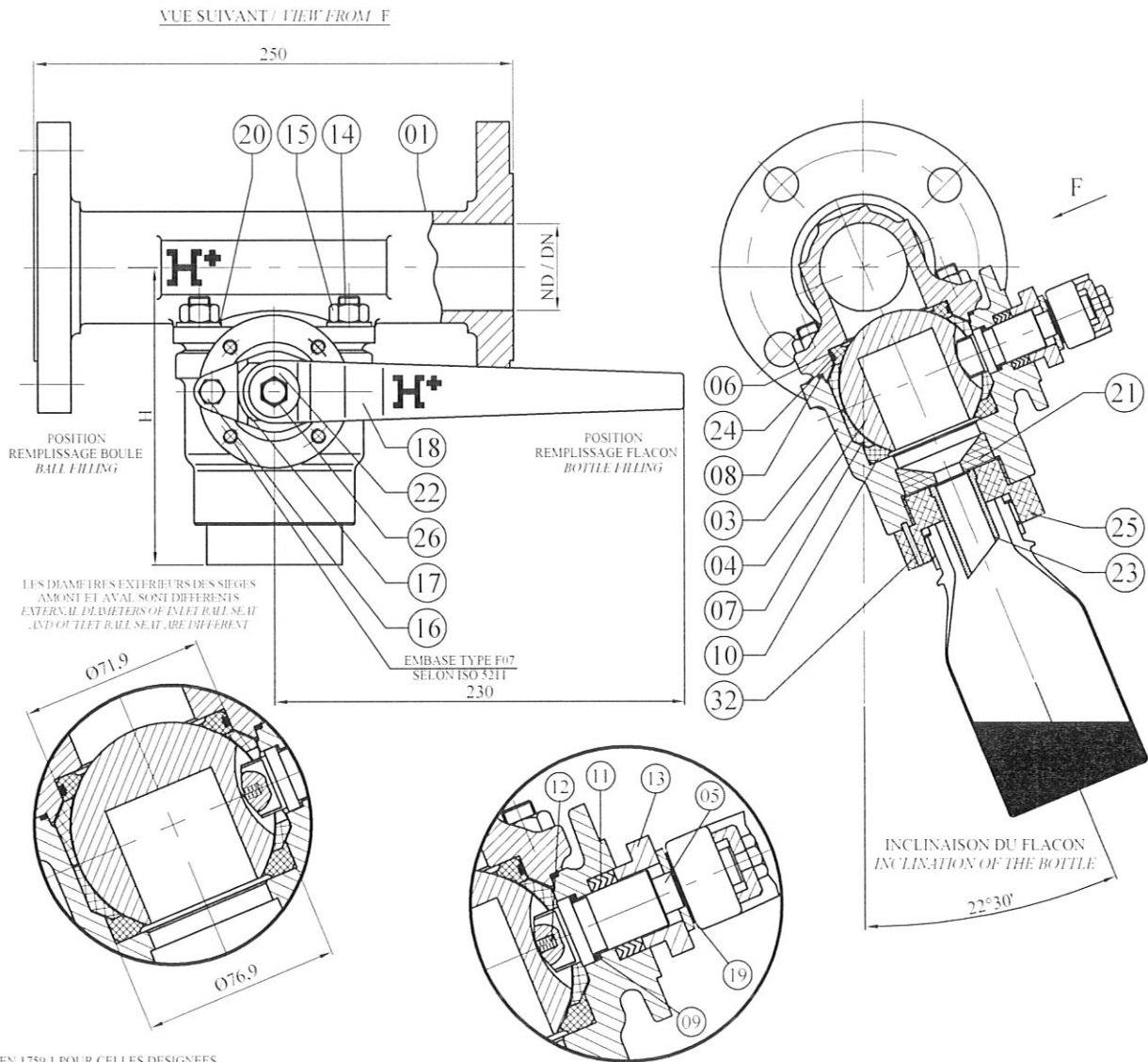

CE DOCUMENT PEUT ETRE MODIFIE SANS AVIS PREALABLE - ALL SPECIFICATIONS SUBJECT TO CHANGE WITHOUT NOTICE

J	10.02.10	MISE A JOUR / UP DATING (FM291)	OZIL	SCHMUNCK
		<b>ROBINET PRISE D'ECHANTILLON</b> <b>FIXED VOLUME SAMPLING CAVITY</b> <b>BALL VALVE - TYPE 2102HI</b> DN/ND 20 à / to 150	<b>2800</b>	

457 Impasse Les collines  
93300 CHISSY-LE MINES  
Tel: 33 (0)4 78 43 91 52  
Fax: 33 (0)4 78 43 91 01  
www.hvalves.com