

ZIPSON'S SJ-Series the steam jacket ball valve are designed for the ball valves on the media to prevent from cooling down. The cool media will become solid, and will be very hard to operate the stem & ball.

The steam jacket ball valve with very well design to help the high temperature steam flow over the valve ball & body parts to keep the media liquid.

Zipson's steam jacket ball valve is designed for easy replacement. The 2-piece, 3-piece, multi-way design will let the user to dismantle the valve for replacing the repair kits or clean the valve if necessary.

For the steam jacket ball valve, the option with cavity filler will effectively help to decrease the remainder in the cavity of the valve body. This PTFE filler will fill the cavity in the valve body over 90%. The other option for steam jacket ball valve is PTFE coating. The PTFE coating will be coated upon the surface of valve body/ bonnet/ end/ ball/ stem. The 40-70 um PTFE coating will keep these steel parts from sticking, and simplify to clean the ball valve.



OPTION

- * with PTFE Cavity filler
- * with PTFE/ PFA coating
- * with bracket & adaptor for cooling the automation

SPECIFICATION

- * Steam jacket were made by 316 or 304 steel plate.
- * Available for Zipson's 1/2/3-piece ball valve
- * Available for Zipson's 3/4-way ball valve
- * Easy replacement design
- * 100% test before shipment

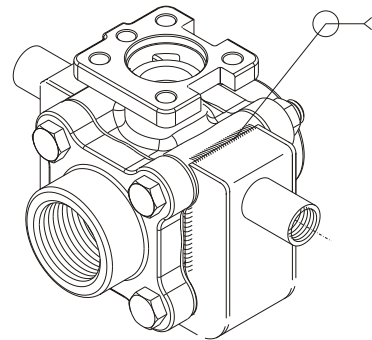

Heating Jacket for 3-piece ball valve
For encapsulated body design
Zipson 305D/ 306D/ 305F/ 306F/ 316T

3/4-WAY BALL VALVE WITH STEAM JACKET

Item 501F, 1/2"~2"

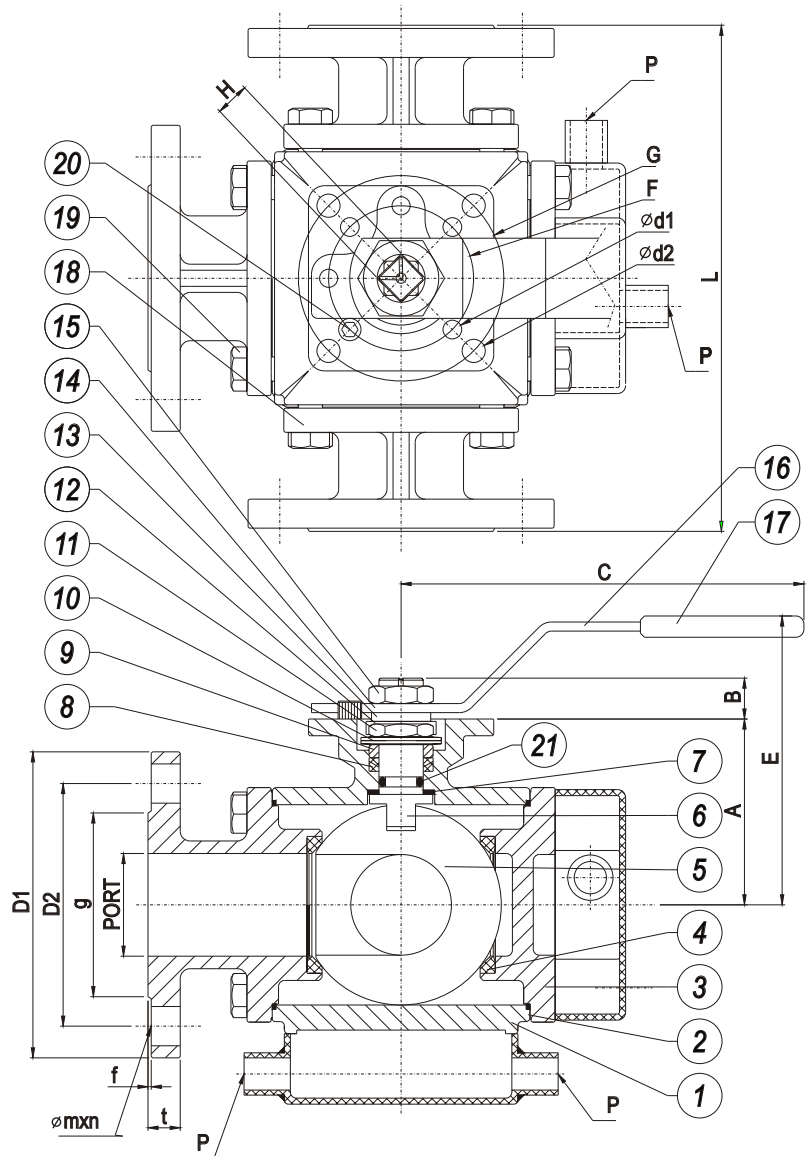
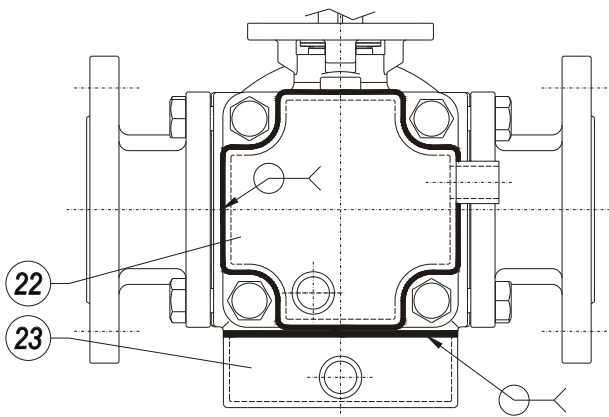

MATERIALS LIST, 1/2" to 2"

ITEM	PART NAME	MATERIALS
1	BODY	A351 Gr. CF8M
2	GASKET	PTFE
3	BLANK CAP	A351 Gr. CF8M
4	SEAT	PTFE
5	BALL	SS 316
6	STEM	SS 316
7	THRUST WASHER	RPTFE
8	STEM PACKING	PTFE
9	GLAND	SS 304
10	DISK WASHER	SS 301
11	STEM NUT	SS 304
12	NUT STOP	SS 304
13	SPACE WASHER	SS 304
14	STOPPER PLATE	SS 304
15	HANDLE NUT	SS 304
16	HANDLE	SS 304
17	SLEEVE	PLASTIC
18	FLANGE END	A351 Gr. CF8M
19	BOLTS	SS 304
20	STOP PIN	SS 304
21	O-RING	VITON
22	BLANK CAP JACKET	SS 304
23	BODY JACKET	SS 304

STEAM JACKET DESIGN
1/2" to 2"

DIMENSIONS (mm) / PN16 (1/2" to 2")

SIZE	A	B	C	d1	d2	E	F	G	H	Port	L	D1	D2	g	t	f	m	n	P
1/2"	41	11	130	6.0	6.0	62	36	42	9	15	160	95	65	45	14	2.0	14	4	3/8"NPT
3/4"	49	14	165	6.0	7.1	82	42	50	11	20	177	105	75	58	16	2.0	14	4	3/8"NPT
1"	55	14	165	6.0	7.1	89	42	50	11	25	190	115	85	68	16	2.0	14	4	3/8"NPT
1-1/4"	63	18	205	7.1	9.2	98	50	70	14	32	208	140	100	78	16	2.0	18	4	1/2"NPT
1-1/2"	74	18	205	7.1	9.2	108	50	70	14	38	234	150	110	88	16	3.0	18	4	1/2"NPT
2"	93	23	325	9.2	11.4	140	70	102	17	50	273	165	125	102	18	3.0	18	4	1/2"NPT

DIMENSIONS (mm) / ASME150 (1/2" to 2")

SIZE	A	B	C	d1	d2	E	F	G	H	Port	L	D1	D2	g	t	f	m	n	P
1/2"	41	11	130	6.0	6.0	62	36	42	9	15	152	89	60.5	35	11.2	1.6	16	4	3/8"NPT
3/4"	49	14	165	6.0	7.1	82	42	50	11	20	167	98	70	43	11.2	1.6	16	4	3/8"NPT
1"	55	14	165	6.0	7.1	89	42	50	11	25	190	108	79.5	51	11.2	1.6	16	4	3/8"NPT
1-1/4"	63	18	205	7.1	9.2	98	50	70	14	32	208	117	89	64	12.7	1.6	16	4	1/2"NPT
1-1/2"	74	18	205	7.1	9.2	108	50	70	14	38	220	127	98.5	73	14.3	1.6	16	4	1/2"NPT
2"	93	23	325	9.2	11.4	140	70	102	17	50	253	152	120.5	92	15.8	1.6	16	4	1/2"NPT

DIMENSIONS (mm) / ASME300 (1/2" to 2")

SIZE	A	B	C	d1	d2	E	F	G	H	Port	L	D1	D2	g	t	f	m	n	P
1/2"	41	11	130	6.0	6.0	62	36	42	9	15	160	95	66.5	35	14.5	1.6	16	4	3/8"NPT
3/4"	49	14	165	6.0	7.1	82	42	50	11	20	177	117	82.5	43	16.0	1.6	19	4	3/8"NPT
1"	55	14	165	6.0	7.1	89	42	50	11	25	200	124	89	51	17.5	1.6	19	4	3/8"NPT
1-1/4"	63	18	205	7.1	9.2	98	50	70	14	32	218	134	98.5	64	20.5	1.6	19	4	1/2"NPT
1-1/2"	74	18	205	7.1	9.2	108	50	70	14	38	234	156	114.5	73	22.5	1.6	22	4	1/2"NPT
2"	93	23	325	9.2	11.4	140	70	102	17	50	273	165	127	92	25.4	1.6	19	8	1/2"NPT

Item 501F, 2-1/2"~4"

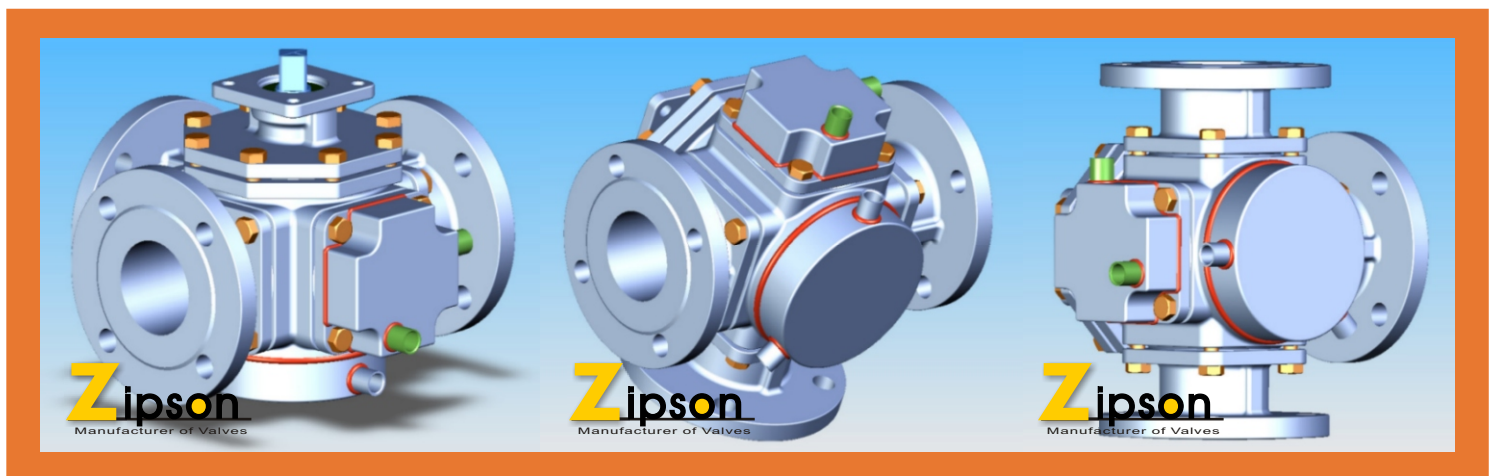

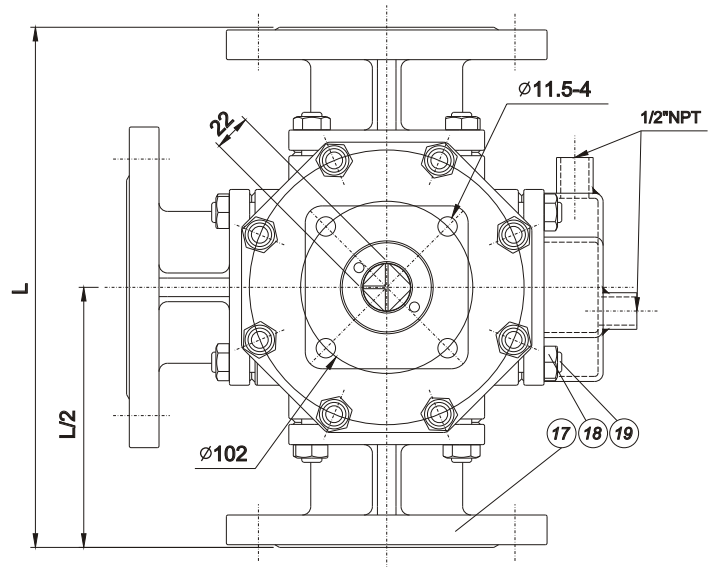
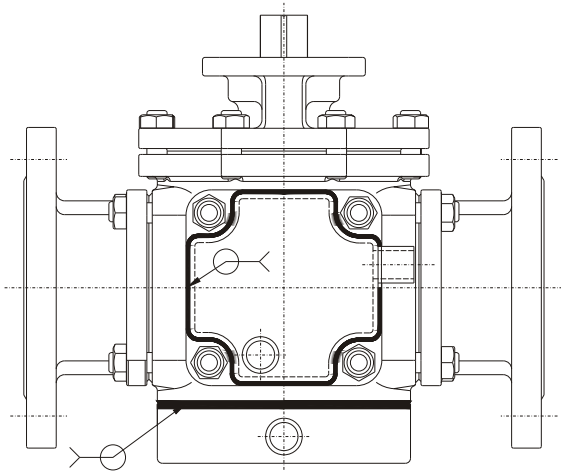

MATERIALS LIST, 2-1/2" to 4"

ITEM	PART NAME	MATERIALS
1	BLANK CAP	A351 Gr. CF8M
2	BODY	A351 Gr. CF8M
3	BALL & STEM	SS 316
4	HOUSING	PTFE + STAINLESS
5	SEATS	PTFE
6	GASKET	PTFE
7	O-RING	VITON
8	STEM PACKING	PTFE
9	GLAND WASHER	SS 304
10	DISK WASHER	SS 301
11	GLAND	SS 304
12	HANDLE HEAD	A351 Gr. CF8
13	STOP PIN	SS 304
14	STOP PIN NUT	SS 304
15	BOLT	SS 304
16	HANDLE	STEEL PIPE
17	FLANGE END	A351 Gr. CF8M
18	BOLTS	SS 304
19	BOLT NUTS	SS 304
20	BONNET	A351 Gr. CF8M
21	BONNET GASKET	PTFE
22	BODY JACKET	SS 304
23	BLANK CAP JACKET	SS 304

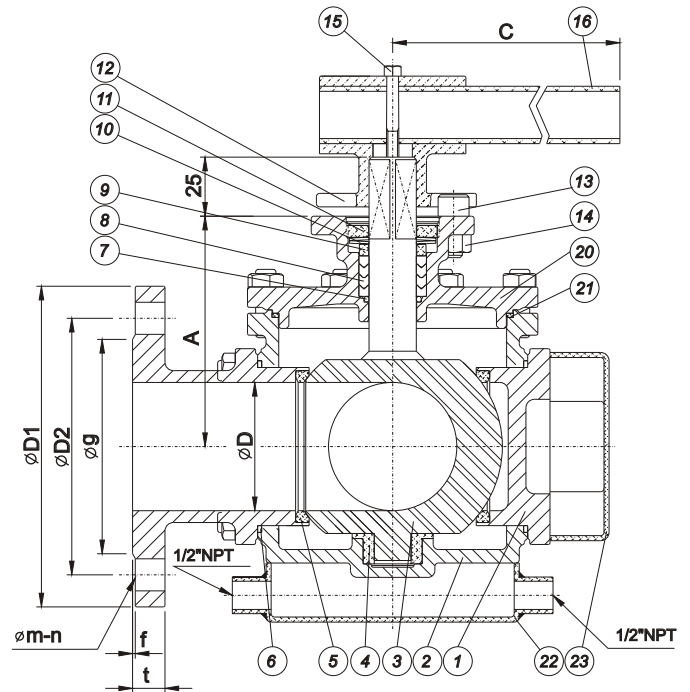

STEAM JACKET DESIGN
2-1/2" to 4"

DIMENSIONS (mm) / PN16 (2-1/2" to 4")

SIZE	A	C	D	H	L	D1	D2	g	t	f	m	n
2-1/2"	118.5	400	62	199	300	185	145	122	18	3.0	18	4
3"	136.5	500	76	217	305	200	160	138	20	3.0	18	8
4"	156.5	650	96	237	368.5	220	180	158	20	3.0	18	8

DIMENSIONS (mm) / ASME150 (2-1/2" to 4")

SIZE	A	C	D	H	L	D1	D2	g	t	f	m	n
2-1/2"	118.5	400	62	199	300	178	139.5	105	17.8	1.6	19	4
3"	136.5	500	76	217	305	190	152.5	127	19.1	1.6	19	4
4"	156.5	650	96	237	368.5	229	190.5	157	24	1.6	19	8

DIMENSIONS (mm) / ASME300 (2-1/2" to 4")

SIZE	A	C	D	H	L	D1	D2	g	t	f	m	n
2-1/2"	118.5	400	62	199	300	190	149	105	25.4	1.6	22	8
3"	136.5	500	76	217	330.4	210	168	127	28.6	1.6	22	8
4"	156.5	650	96	237	393.8	254	200	157	32	1.6	22	8

1-PIECE FLANGED BALL VALVE WITH STEAM JACKET

Item 107S, ASME150, 1/2"~4"

MATERIALS LIST, 2-1/2" to 4"

ITEM	PART NAME	MATERIALS
1	BODY	A351 Gr. CF8M
2	GASKET	PTFE
3	INSERT CAP	A351 Gr. CF8M
4	BALL	SS316
5	BALL SEATS	PTFE
6	STEM	SS316
7	THRUST WASHER	RPTFE
8	ANTISTATIC DEVICE	SS316
9	O-RING	VITON
10	STEM PACKING	PTFE
11	GLAND WASHER	SS 304
12	DISK WASHER	SS 301
13	STEM NUT	SS 304
14	NUT LOCK	SS 304
15	GLAND WASHER	SS 304
16	POSITION SCREW	SS 304
17	HANDLE NUT	SS 304
18	HANDLE	SS 304
19	HANDLE COVER	PLASTIC
20	SET BOLT	SS 304
21	LEVER HEAD	CF8
22	LEVER	STEEL PIPE
23	STOPPER	SS 304
24	JACKET	SS 304

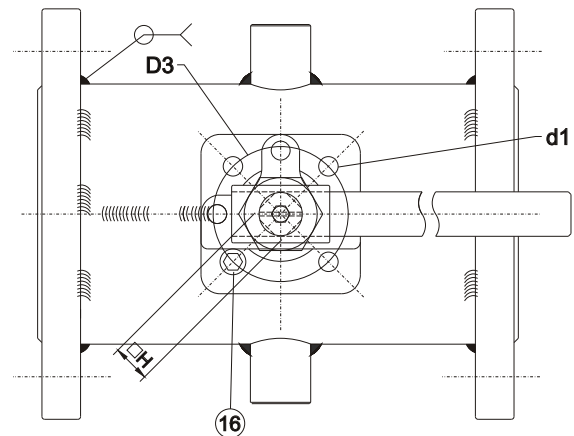
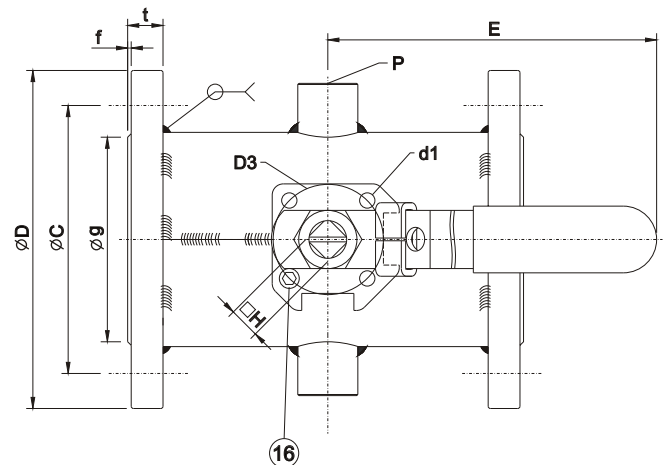

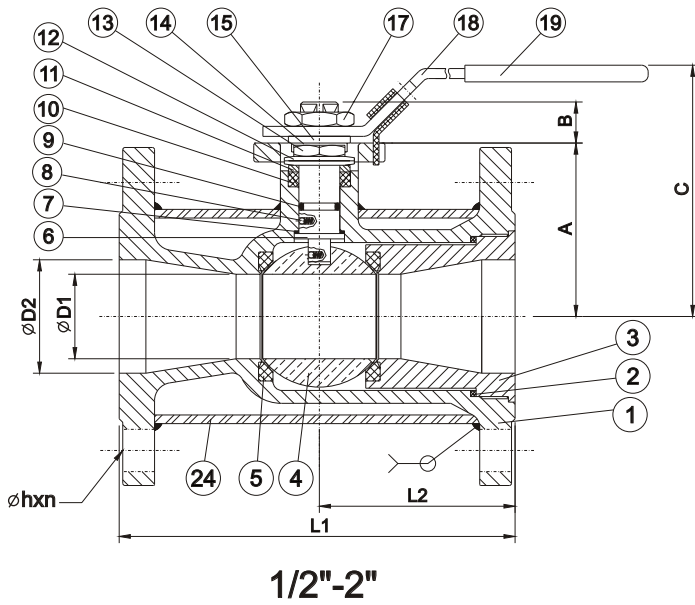

1/2"-2"

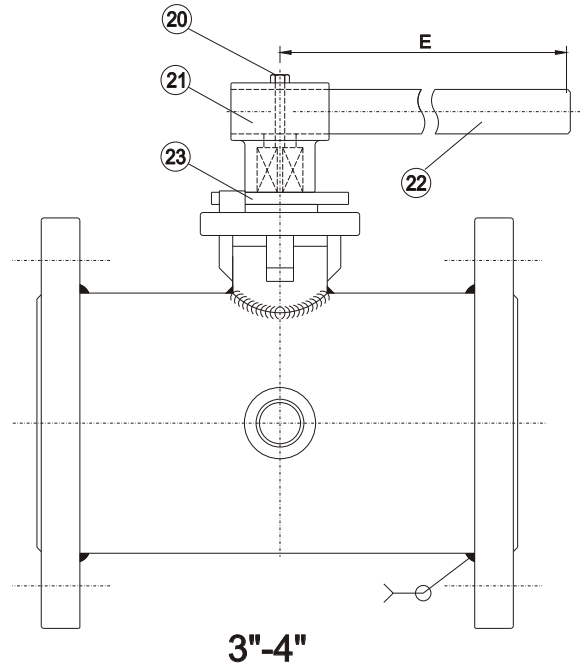

3"-4"

DIMENSIONS (mm)

SIZE	A	B	C	D1	D2	D3	d1	E	H	L1	L2	FLANGE DIMENSIONS (CLASS 150)							P
												D	BOLTHOLE			t	g	f	
													C	h	n				
1/2"	47	11	80	12.5	15	F3/F4	6/6	130	9	108	48	89	60.5	16	4	11.5	35	1.6	3/8"NPT
3/4"	53	11	80	15	20	F3/F4	6/6	130	9	117	50	98	70	16	4	11.5	43	1.6	3/8"NPT
1"	58	11	82	20	25.4	F3/F4	6/6	130	9	127	50	108	79.5	16	4	11.5	51	1.6	3/8"NPT
1-1/2"	65	14	95	31.8	38.1	F5	7	165	11	165	60	127	98.5	16	4	14.3	73	1.6	1/2"NPT
2"	77	18	120	38.1	50.8	F5	7	205	14	178	75	152	120.5	19	4	15.9	92	1.6	1/2"NPT
3"	98	23	155	58	76.2	F7	9.2	340	17	203	85	190	152.5	19	4	19.1	127	1.6	1/2"NPT
4"	118	23	185	76	101.6	F7	9.2	340	17	229	95	229	190.5	19	8	24.0	157	1.6	1/2"NPT

2-PIECE FLANGED BALL VALVE WITH STEAM JACKET

