

**ADCAMAT PACKAGED AUTOMATIC PUMP
(Suitable for steam supply)
POPS-KD (Duplex)**

DESCRIPTION

The POPS-K packaged pump units can be used to lift or displace hot condensate and other liquids even in hazardous areas.

A POPS-KD (Duplex) packaged unit is comprised by two Adcamat pumps in parallel, a vented receiver and all auxiliary items, compactly mounted on a metal frame, piped and ready for connection.

For operating conditions and pumping capacities, please refer to the information sheet IS 9.101 E.

All connections are flanged EN 1092-1 PN16. Threaded flanges and/or other connection standards available on request.



How to order: i.e. ADCAMAT POPS-KD carbon steel packaged pump, steam operated, flanged PN16 DN 80x50.

CE MARKING – GROUP 2 (PED – European Directive)

PN16	Category
All sizes	2 (CE marked)

MATERIALS	
POS. N°	DESIGNATION
1	POPS pumps
2	Receiver
3	MWS1 wafer ball valve
4	IS16F strainer
5	RD40 disc check valve
6	M3i ball valve
7	Overflow
8	IS140 Y strainer
9	UCX41 + UBS20 steam trap
10	Metal frame

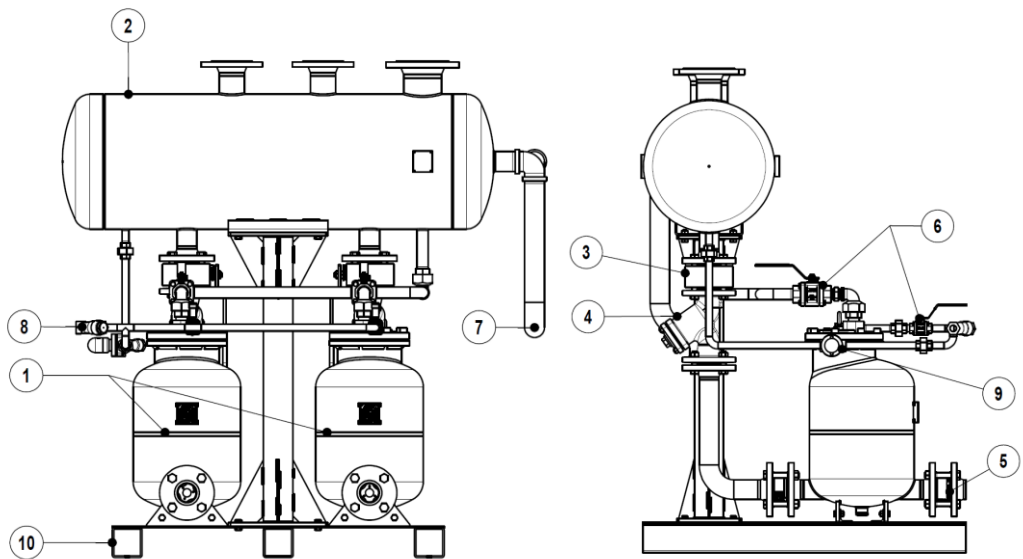

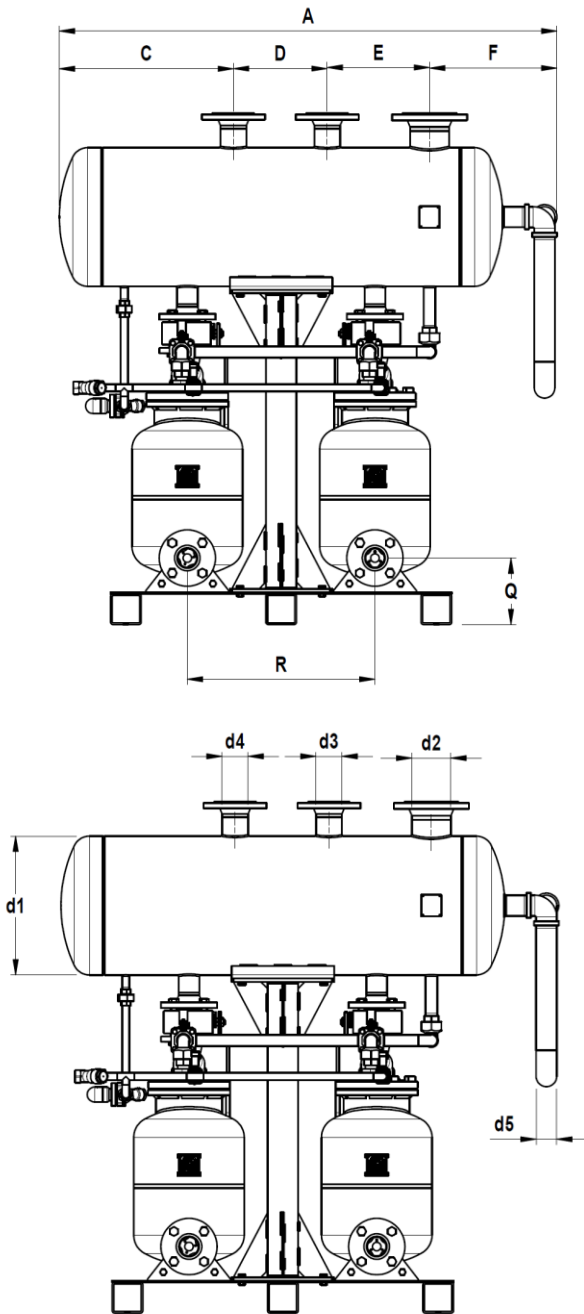

LIMITING CONDITIONS:
Receiver – Max. operating pressure: 0,5 bar.
Pump: See IS 9.101 E.

CONNECTIONS SIZE					
DN	d1 (mm)	d2	d3	d4	d5
2 x DN 50x50	406	DN 100	DN 65	DN 65	2"
2 x DN 80x50	406	DN 150	DN 80	DN 80	2"

d2 – vent; d3 and d4 – condensate inlets; d5 – overflow.

DIMENSIONS (mm)																	
DN	A	B	C	D	E	F	G	H	I	J	L	M	N	O	P	Q	R
2 x DN 50x50	1460	1497	510	275	300	374	0	150	309	31	1000	1000	205	795	693	195	550
2 x DN 80x50	1509	1509	555	275	300	378	96	175	303	44	1000	1000	205	795	703	208	550

Dimensions subject to change without notice. Consult factory for certified dimensions and weight.