

CENTRIFUGAL AIR AND DIRT SEPARATORS For liquid systems AS – AS/F

DESCRIPTION

The AS series centrifugal air and dirt separators were designed to be used in the flow line of a hydronic heater or cooling system. The operation is based on the principle of centrifugal force, instead of relying on low velocity separation, offering the advantage of efficient separation in a smaller vessel.

The ADCA AS units provide maximum separation efficiency while minimizing space requirements. The inside strainer protects against any dirt present in the system such as sand, welding residues, etc. The strainer screen position has a particular advantage compared with external pipe strainers because the dirt is removed from the water flow and is collected in the reservoir bottom, avoiding pressure drop increase.



OPTIONS: Galvanised and complete stainless steel construction.

USE: To remove air and dirt in hydronic heating, cooling and pumping systems.

AVAILABLE

MODELS: AS/S - carbon steel body.
AS/SZ - zinc plated body.
AS/SS - stainless steel body.
AS/SF - carbon steel with strainer.

SIZES: 1 1/4" to 2".
DN 32 to DN 300.

CONNECTIONS: Female screwed ISO 7/1 Rp (BS21).
Flanged EN 1092-1 or ANSI.
Special flanges upon request.

INSTALLATION: The AS separators should be installed at the highest temperature and lowest pressure points, where solubility is lower. Ideally, they should be installed after boilers or heat exchangers, before chillers and before pump suction. Horizontal installation, always with the drain discharge pointing downwards. The installation of an ADCA AE series air eliminator is recommended, to remove the air.

CE MARKING – GROUP 2 (PED – European Directive)

PN16	PN40	Category
DN 32 to DN 300	DN 32 to DN 200	SEP
–	DN 250 to DN 300	1 (CE Marked)

LIMITING CONDITIONS - AS/S *								
Rating	Pressure (bar)	Temp. (°C)	Rating	Pressure (bar)	Temp. (°C)	Rating	Pressure (bar)	Temp. (°C)
PN16	16	50	ANSI 150 lb	16	50	PN40 / ANSI 300 lb	40	50
	14	100		14	100		37	100
	13	195		13	195		31	239
	12	250		–	–		27	300

Minimum operating temperature: -10 °C; Design code: AD-Merkblatt.

* Ratings according to EN 1092-1:2018;

LIMITING CONDITIONS - AS/SS *								
Rating	Pressure (bar)	Temp. (°C)	Rating	Pressure (bar)	Temp. (°C)	Rating	Pressure (bar)	Temp. (°C)
PN16	16	50	ANSI 150 lb	16	50	PN40 / ANSI 300 lb	40	50
	14	100		16	100		40	100
	13	195		13	195		32	240
	12	250		–	–		30	300

Minimum operating temperature: -10 °C; Design code: AD-Merkblatt.

* Ratings according to EN 1092-1:2018;

MATERIALS	
DESIGNATION	MATERIAL
Body	EN 10216-2 / P235GH / 1.0325
Heads	EN 10028-2 / P265GH / 1.0425
Inlet / outlet pipes	EN 10216-2 / P235GH / 1.0325
EN flanges	EN 10222-2 / P250GH / 1.0460
ANSI flanges	ASTM A105 / 1.0432
Sockets	ASTM A105 / 1.0432
Internals	EN 10025-2 / S235JR / 1.0038
Strainer	AISI 304 / 1.4301

FLANGE CONNECTIONS			
RATING	SIZE	EN STANDARD	ANSI STANDARD
PN16 *	DN 32 to DN 50	EN 1092-1 PN40	ANSI B16.5 Cl. 150 lb
PN16	DN 65 to DN 300	EN 1092-1 PN16	ANSI B16.5 Cl. 150 lb
PN40	DN 32 to DN 300	EN 1092-1 PN40	ANSI B16.5 Cl. 300 lb

* Flanges EN 1092-1:2018 PN16 and PN40, from DN 32 to DN 50, have the same number and size of holes.

APPROXIMATE DIMENSIONS (mm) *																	
SIZE DN	A1 PN16	A PN16	A PN40	A 150 lb	A 300 lb	B	C	C1	D	D1	E	F **	F1 **	G	H **	VOL. (L)	WGT. (kg)
32	263	260	260	290	306	140	395	495	285	385	110	3/4"	1/2"	1/2"	3/4"	6	13
40	263	260	260	294	307	140	435	535	325	425	110	3/4"	1/2"	1/2"	3/4"	6,7	14,3
50	322	310	310	341	354	168	505	605	385	485	120	3/4"	1/2"	1/2"	3/4"	11,7	21
65	–	380	394	430	442	219	550	670	410	530	140	1"	3/4"	3/4"	1"	19,8	31,5
80	–	400	416	440	459	219	610	730	462	582	148	1"	3/4"	3/4"	1"	27	40
100	–	485	511	533	553	273	715	835	528	648	187	1 1/4"	3/4"	3/4"	1 1/4"	38	59,8
125	–	535	561	605	622	324	845	995	630	780	215	1 1/4"	1"	1"	1 1/4"	54	84
150	–	565	605	635	652	356	962	1131	692	841	290	1 1/2"	1"	1"	1 1/2"	79	161
200	–	605	657	685	703	406	1170	1320	880	1030	290	1 1/2"	1"	1"	1 1/2"	146	202
250	–	720	790	784	815	508	1540	1710	1140	1310	400	1 1/2"	1"	1"	1 1/2"	288	330
300	–	840	914	913	944	610	1700	1870	1172	1342	528	1 1/2"	1"	1"	1 1/2"	412	475

* Weight and volume refer to PN16 AS/SF design. Other ratings or designs may have slightly different volumes. For certified dimensions, consult factory.

** Screwed drain connection, as standard. Alternatively, they can be supplied with EN 1092-1 or ANSI flanges with the same class as the main dimensions.

Dimensions subject to change without notice.

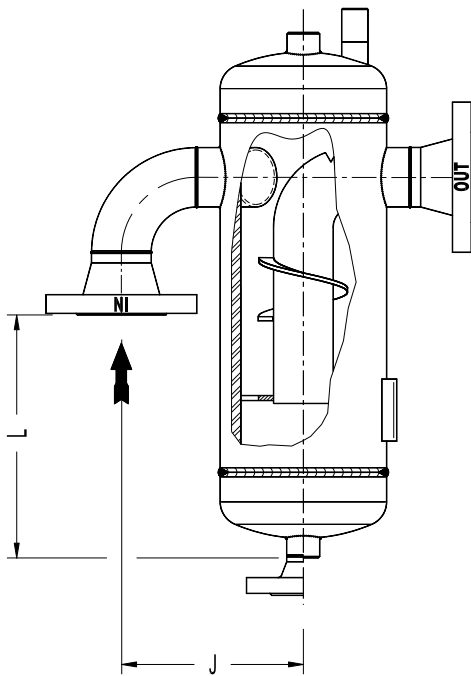
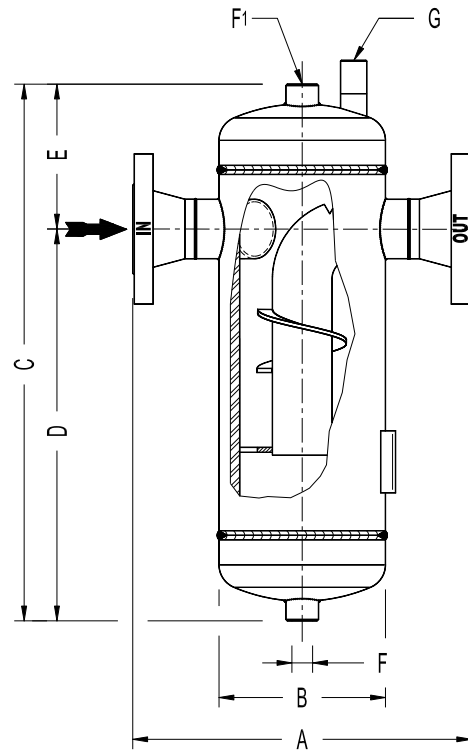
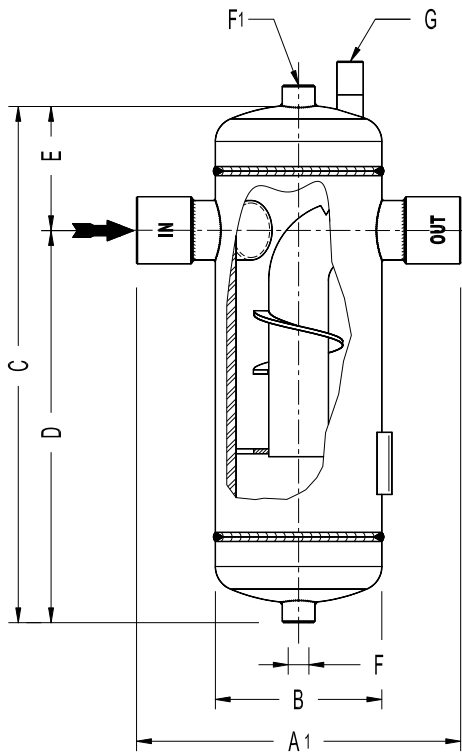

EVH version

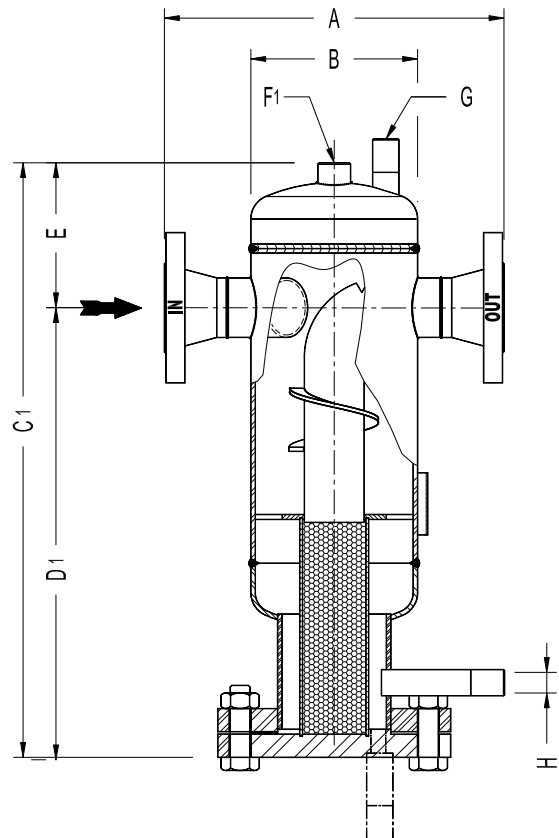

F	Drain connection
F1	Automatic air eliminator connection
G	Manual start-up air drain connection
H	Strainer drain connection