

TANK BLANKETING REGULATORS BKRI2 (Low pressure regulator)

DESCRIPTION

Tank blanketing valves are commonly used in tank storage systems to prevent and protect against explosions (avoiding flammable liquids being vented from vessel), to control product contamination against external air that may fill the vapour space, to reduce evaporation losses (consequently, production losses), to reduce internal corrosion (caused by air and moisture) and to prevent vacuum condition.

The blanketing process consists in covering the stored medium, usually a liquid, with a gas (normally N₂).

MAIN FEATURES

Compact design.
No rising stem, except when supplied with top cap.

STANDARD SURFACE FINISH

Internal movable parts and machined surfaces:

≤ 0,76 micron Ra – SF3.

Other surfaces: as casted.

Ultrasonic cleaning.

OPTIONS:

- Diaphragm leakage line connection.
- Gauge connection on body.
- External pulse line (recommended for low set pressures < 10 mbar or high flow).
- Dome loaded (for higher pressure control).
- Blanketing with vacuum.
- Top cap (adjusting screw sealing).
- ATEX version.

USE: Compressed air, nitrogen and other gases compatible with the construction.

AVAILABLE

MODELS: BKRI2 – Low pressure regulator.

SIZES: DN 15 and DN 25.

CONNECTIONS: Flanged EN 1092-1 PN16.

OUTLET SPRING

RANGES: 5 to 500 mbar (4000 mbar with dome load).

INSTALLATION: Vertical installation recommended (to allow draining) or horizontal as close to process as possible in order to prevent long pipe sections and flow restrictions.

For an economical consumption of blanketing gas, the pressure must be adjusted to remain slightly above the atmospheric pressure, while filling and emptying the vessel.

ORDER

REQUIREMENTS: Type of fluid.
Maximum operating temperature.
Inlet pressure and required outlet pressure.
Capacity (maximum and minimum).



CE MARKING (PED – European Directive)

PN16	Category
DN 15 to 25	SEP

CE MARKING – ATEX VERSION (ATEX – European Directive)

PN16	Category
DN 15 to 25	Ex h IIB T6...T3 Gb

AIR CAPACITIES (Nm ³ /h) Max. inlet pressure 6 bar – Seat Ø 8 mm										
SIZE DN	OUTLET PRESS.	INLET PRESSURE (barg)								
		0,1	0,5	0,8	1	2	3	4	5	6
15	5 to 10	3,5	18	28	37	56	77	92	111	128
15	10 to 50	3,5	18	28	37	56	77	92	111	128
15	20 to 200	–	18	28	37	56	77	92	111	128
15	50 to 500	–	–	–	37	56	77	92	111	128
25	5 to 10	4	20	32	40	63	85	102	125	140
25	10 to 50	4	20	32	40	63	85	102	125	140
25	20 to 200	–	20	32	40	63	85	102	125	140
25	50 to 500	–	–	–	40	63	85	102	125	140

Outlet pressure should not be more than 50% of the inlet, in order to reach the mentioned flow rates.

AIR CAPACITIES (Nm ³ /h) Max. inlet pressure 12 bar – Seat Ø 5 mm							
SIZE DN	OUTLET PRESS.	INLET PRESSURE (barg)					
		2	4	6	8	12	16
15	5 to 10	18	32	43	54	81	106
15	10 to 50	18	32	43	54	81	106
15	20 to 200	18	32	43	54	81	106
15	50 to 500	18	32	43	54	81	106
25	5 to 10	21	35	49	62	90	118
25	10 to 50	21	35	49	62	90	118
25	20 to 200	21	35	49	62	90	118
25	50 to 500	21	35	49	62	90	118

Outlet pressure should not be more than 50% of the inlet, in order to reach the mentioned flow rates.

DIMENSIONS (mm) FLANGES DIN EN PN16						
SIZE DN	A	B	C	D	d1	WGT. (kg)
15	130	47,5	243,5	230	1/4"	9,7
25	160	57,5	243,5	230	1/4"	10,8

LIMITING CONDITIONS		
Valve model	BKR12	
Body design conditions	PN16	
Max. upstream pressure	Seat Ø 5 mm	12 bar
	Seat Ø 8 mm	6 bar
Max. downstream pressure	500 mbar	
Min. downstream pressure	5 mbar	
Max. design temperature *	130 °C	

* Other on request.

Warning: Blanketing valves are not substitute of safety valves or vacuum relief valves.

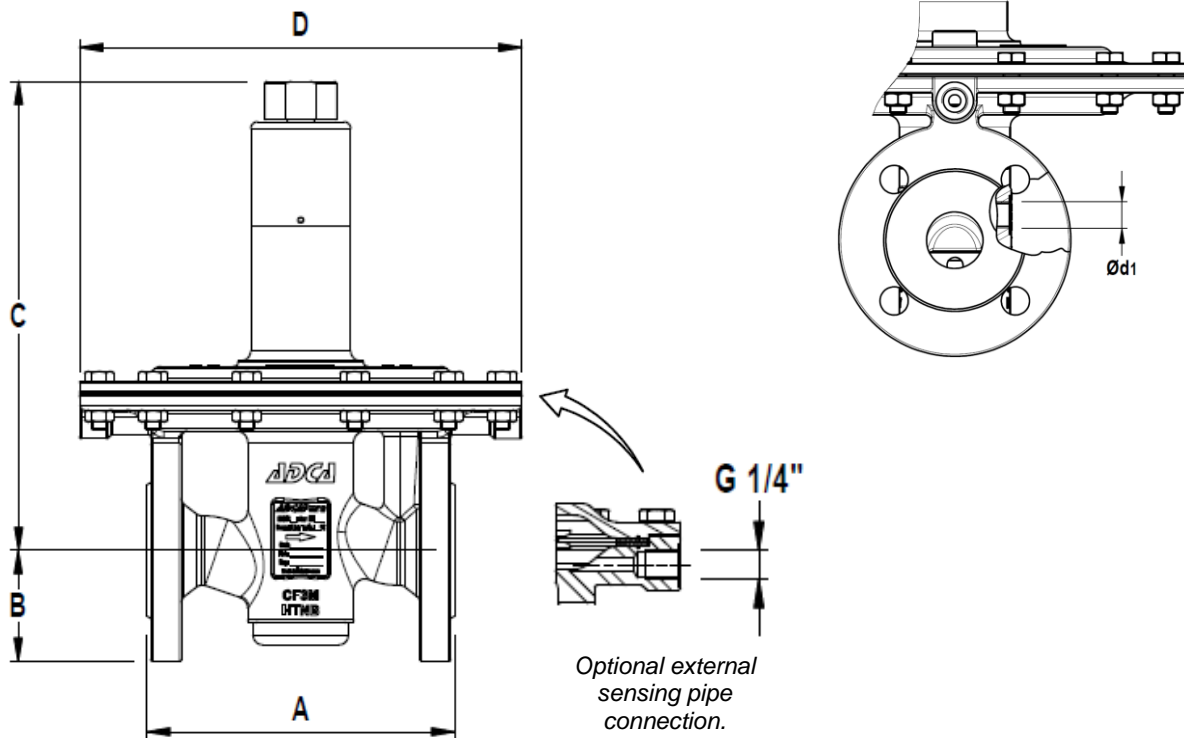

MATERIALS		
POS. N°	DESIGNATION	MATERIAL
1	Valve body	CF3M / 1.4409
2	Diaphragm top cover	CF3M / 1.4409
3	Seat cover	AISI 316L / 1.4404
4	* O-ring	EPDM
5	* Piston	AISI 316L / 1.4404
6	* Valve head	AISI 316L / 1.4404
7	* O-ring	EPDM
8	* Valve Spring	AISI 302 / 1.4300 (Polished)
9	Seat	AISI 316L / 1.4404
10	* O-ring	EPDM
11	Piston guide	PTFE
12	Stem	AISI 316L / 1.4404
13	Stem guide	PTFE
14	Retaining ring	Stainless steel A2
15	Diaphragm plate	AISI 316L / 1.4404
16	* O-ring	EPDM
17	Bolts	Stainless steel A2-70
18	Nuts	Stainless steel A2-70
19	Spring cover	AISI 316L / 1.4404
20	* Lower diaphragm	PTFE (Gylon)
21	* Upper diaphragm	EPDM
22	Diaphragm plate	AISI 316L / 1.4404
23	Nut	Stainless steel A2-70
24	Washer	AISI 316 / 1.4401
25	Lower spring guide	AISI 316L / 1.4404
26	* Regulating spring	AISI 302 / 1.4300
27	Top spring plate	AISI 316L / 1.4404
28	Adjustment screw	Brass /
29	Bearing	Corrosion resistant steel
30	* O-ring	NBR
31	Regulating nut	AISI 316L / 1.4404
32	Ext. bowed shaft ring	Stainless steel
33	Cover nut	Plastic

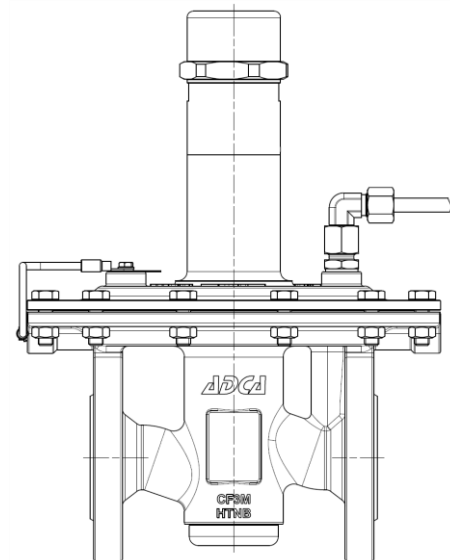
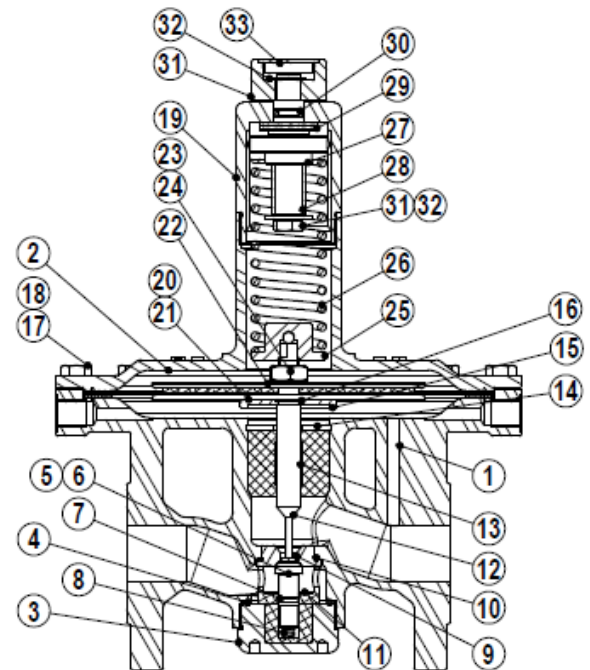

ATEX compliant version.

* Available spare parts;

FDA / USP Class VI seals certificate on request.

All valves have a serial number. In case of non standard valves, this number must be supplied if spare parts are ordered.

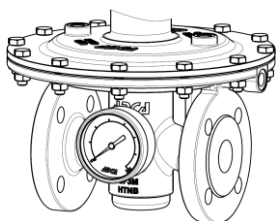

Optional pressure gauge connection.

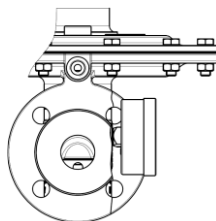

Optional top cap adjusting screw sealing.

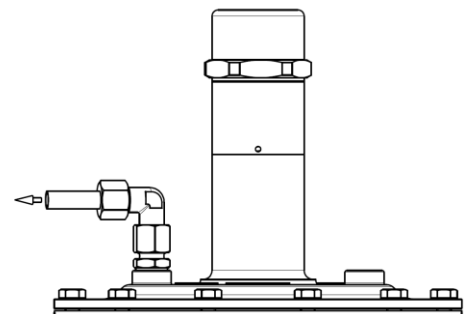
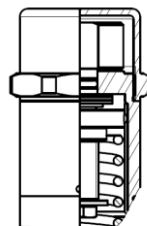

Optional 1/4" diaphragm leakage connection.

TYPICAL INSTALLATION

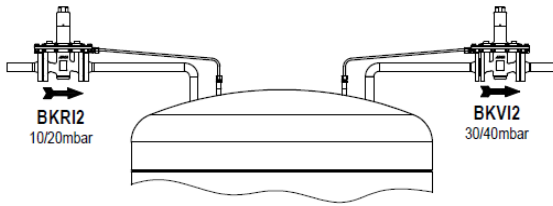

Blanketing with overpressure

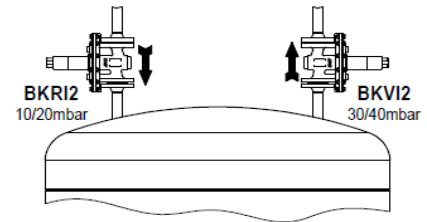

ORDERING CODES BKRI2													
Valve model	BRI	A	5	T	E	I	X	X	X	0	L	15	E
BKRI2 – CF3M / 1.4409 Blanketing low pressure regulator	BRI												
Outlet spring range													
Dome loaded for higher pressure control	A												
5 to 10 mbar	0												
10 to 50 mbar	1												
20 to 200 mbar	2												
50 to 500 mbar	3												
Valve seat orifice													
Seat diameter 5 mm	5												
Seat diameter 8 mm	8												
Diaphragm material													
PTFE (Gylon)				T									
Valve head													
EPDM					E								
Regulating knob, top cap and captured vent													
Stainless steel regulating knob						I							
Top cap (adjusting screw sealing)							T						
Stainless steel regulating knob w/ diaphragm cover leakage connection in case of diaphragm failure								L					
Top cap (adjusting screw sealing) w/ diaph. cover leakage connect. in case of diaphragm failure (a)									U				
Gauge port options													
Without gauge ports									X				
Threaded gauge port on the left side (rel. to the flow direction) – Downstream pressure										4			
Threaded gauge port on the right side (rel. to the flow direction) – Downstream pressure											3		
Threaded gauge port on both sides - Downstream pressure												2	
Surface finish, special services and options													
None													X
Mechanical polishing													P
Electropolishing													E
Special features													
None													X
External pulse line													
Internal pulse orifice (standard)												0	
External pulse line connection 1/4"													1
Pipe connection													
Flanged EN 1092-1 PN16													L
Size													
DN 15													15
DN 25													25
Special valves / Extras													
ATEX compliant version													EX
Full description or additional codes have to be added in case of a non standard combination													E

(a) Choose this option in case of ATEX compliant version.