

DOUBLE WINDOW SIGHT GLASS DW40S (Carbon steel)

DESCRIPTION

For monitoring the right operation of a steam trap, in order to avoid leakages of live steam and, consequently, great energy losses, a sight glass is recommended to be installed downstream of the steam trap.

The double window DW40 sight glasses have been designed for this particular application.

Connections are female screwed or flanged.

OPTIONS: Mica shield discs for use with steam.

USE: Condensate pipes, downstream of the steam traps.

AVAILABLE MODELS: DW40S.

SIZES: 1/2" to 2"; DN 15 to DN 50.

CONNECTIONS: Female screwed ISO 7/1 Rp (BS21).
NPT (ANSI B1.20.1).
Flanged EN 1092-1 or ANSI.

INSTALLATION: Horizontal or vertical installation.
See IMI – Installation and maintenance instructions.



1/2" - 1"



1 1/4" - 2"



BODY LIMITING CONDITIONS			
ALLOWABLE PRESSURES			RELATED TEMP.
PN40 / ANSI 300 lb	PN25	ANSI 150 lb	
40 bar	25 bar	19,3 bar	-10 / 50 °C
37,1 bar	23,2 bar	17,7 bar	100 °C
35,2 bar	22 bar	15,8 bar	150 °C
33,3 bar	20,8 bar	14 bar	200 °C
28,7 bar	17,9 bar	11,7 bar	280 °C

For applications with steam, use mica shield discs.

CE MARKING – GROUP 2 (PED – European Directive)			
PN40 / ANSI 300 lb	PN25	ANSI 150 lb	Category
1/2" to 1" – DN 15 to DN 25	1 1/4" to 1 1/2" – DN 32 to DN 40	1/2" to 2"	SEP
–	2" – DN 50	–	1 (CE Marked)

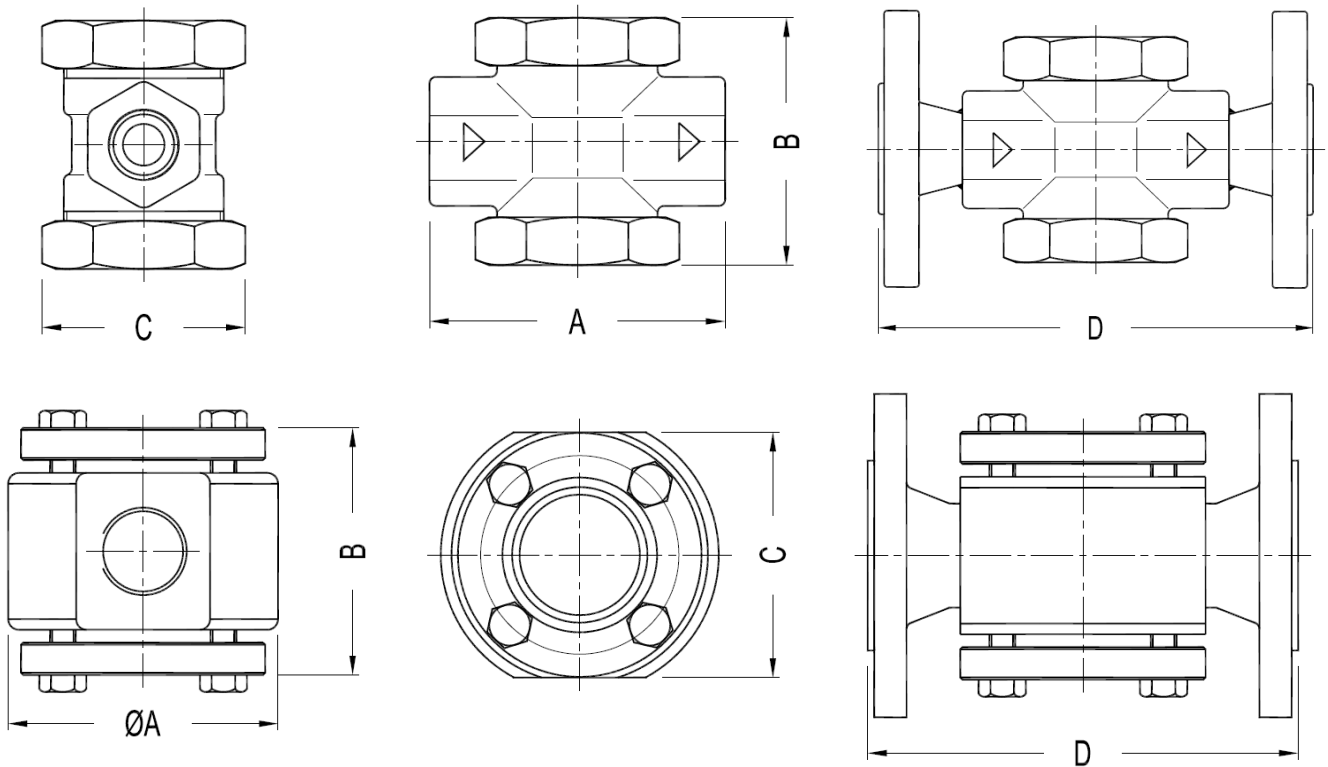

DIMENSIONS						
SCREWED				FLANGED *		
SIZES	A	B	C	WGT. (kg)	D	WGT. (kg)
1/2" – DN 15	90	80	60	1,25	150	2,8
3/4" – DN 20	90	80	60	1,25	150	3,4
1" – DN 25	100	87	65	2,1	160	4,7
1 1/4" – DN 32	130	115	114	6,2	180	9,5
1 1/2" – DN 40	130	115	114	6,5	200	10,5
2" – DN 50	130	125	114	7,5	230	12,5

* Values refer to EN1092-1 flanges. For other versions, consult factory.

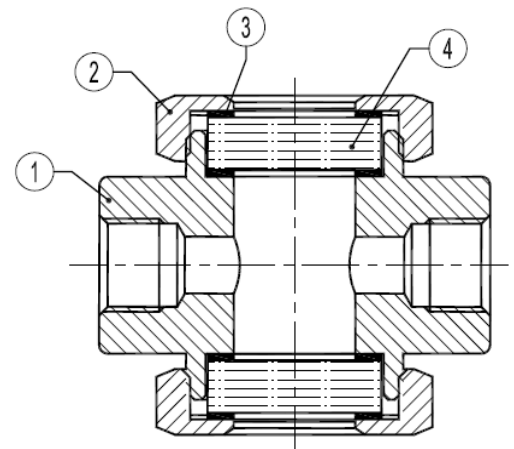

MATERIALS			
POS. Nº	DESIGNATION	1/2" to 1" DN 15 to DN 25	1 1/4" to 2" DN 32 to DN 50
1	Body	P250GH / 1.0460	S355J2G3 / 1.0570 P250GH / 1.0460
2	Glass nut / flange	P250GH / 1.0460	S355J2G3 / 1.0570
3	* Gasket	Stainless steel / Graphite	Stainless steel / Graphite
4	* Window glass	Tempered borosilicate glass	Tempered borosilicate glass
5	Bolts	–	Steel 8.8

* Available spare parts.

