

COMPRESSED AIR BALL FLOAT TRAPS FA21SS (Stainless Steel)

DESCRIPTION

The FA21SS series compressed air float traps are specially designed for draining water from high pressure compressed air and gas lines.

Usual applications include aftercoolers, separators and compressed air and gas mains.

An air balance pipe must be fitted, to allow the air trapped in the FA21SS body to escape, avoiding obstructing the condensate flow.

Connections are flanged or female screwed.



MAIN FEATURES

Modulating discharge.

Unaffected by sudden or wide load and pressure changes.

OPTIONS: Equalizing and drain plug on body.
Lifting lever.

USE: Compressed air and non corrosive gases compatible with the construction.

AVAILABLE MODELS:

FA21SS-21.

SIZES: 1/2" to 1", DN 15 to DN 25.

CONNECTIONS: Female screwed ISO 7/1Rp (BS21).
Flanged EN1092-1 PN40 or ANSI.

INSTALLATION: Horizontal or vertical installation.

APPLICATION LIMITS	
Min. liquid specific weight	0,75 kg/dm ³
Maximum working diff. pressure	21 bar

CE MARKING – GROUP 2 (PED – European Directive)	
PN25	Category
1/2" to 1" – DN 15 to 25	SEP

BODY LIMITING CONDITIONS		
FLANGED PN25 / ANSI 300 lb *	FLANGED ANSI 150 lb **	RELATED TEMP.
ALLOW. PRESS.	ALLOW. PRESS.	
25 bar	16 bar	100 °C
22,7 bar	14,8 bar	150 °C
21 bar	13,6 bar	200 °C
19,8 bar	12 bar	250 °C

PMO – Max. operating press. 21 bar;

TMO – Max. operating temp. 200 °C;

* According to EN1092-1:2018; ** According to EN1759-1:2004;
Body limiting conditions PN25 or below, depending on the type of connections adopted. Rating PN25 for thread, SW and BW.

FLOW RATE CAPACITY (kg/h)																
MODEL	SIZE	DIFFERENTIAL PRESSURE (bar)														
		0,5	1	1,5	2	3	4,5	6	7	8	9	10	12	14	16	21
FA21SS	1/2" to 1" DN 15 to 25	75	100	125	155	180	220	255	275	290	305	320	345	375	420	480

DIMENSIONS (mm)

SIZE	Screwed					PN16/40		ANSI 150 lb		ANSI 300 lb	
	A	B	C	D	WGT. (kg)	F	WGT. (kg)	F	WGT. (kg)	F	WGT. (kg)
1/2" – DN 15	95	178	23	128	5,2	150	6,7	150	6,2	150	7
3/4" – DN 20	95	178	23	128	5,2	150	7,4	150	6,6	150	8,2
1" – DN 25	95	178	23	128	5,2	160	7,8	160	7,4	160	9

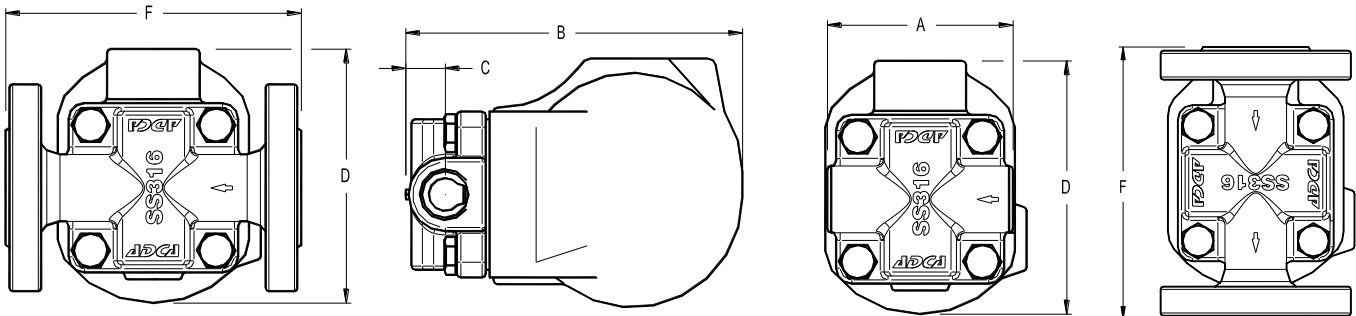
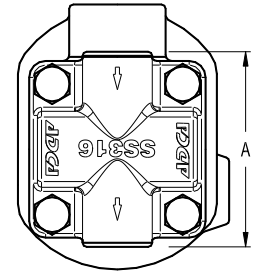

MATERIALS

POS. N°	DESIGNATION	MATERIAL
1	Body	CF8M / 1.4408
2	Cover	CF8M / 1.4408
3	* Gasket	Stainless steel / Graphite
4	* Seat	AISI 410 / 1.4006
5	* Valve	Viton
		** AISI 410 / 1.4006
6	* Lever	AISI 304 / 1.4301
7	* Float	AISI 304 / 1.4301
8	** Compression fitting	St. steel or Steel Fe/Zn
9	Bolts	Stainless steel A2-70

* Available spare parts. ** Optional.

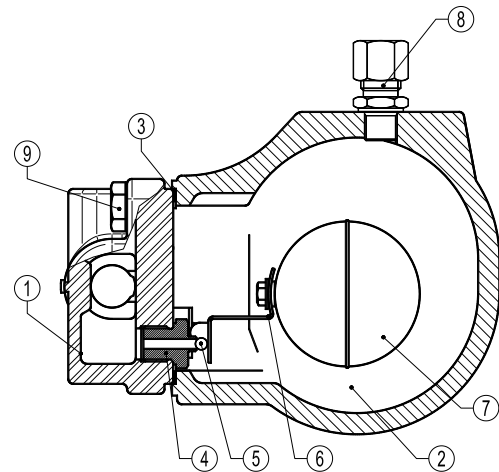

TYPICAL INSTALLATION

