

CULINARY STEAM FILTER ISC20I

DESCRIPTION

The ISC20I high efficiency filters are used to remove contaminated particles from gases such as steam and compressed air.

The optimized construction of these units offers low differential pressure at high flow rates.

All sizes are built in two halves, joined by a sanitary clamp ferrule according to DIN 32676 Series A, with drain connection on bottom.

The filter elements (replaceable) are made of sintered austenitic stainless steel.

MAIN FEATURES

Several retention rates available.

Good durability against aggressive gases.

Porosity level is more than 50% ensuring high particle and dirt load capacity as well as good flow rate at a low differential pressure.

Regeneration by ultrasonic bath.

STANDARD SURFACE FINISH

Internal parts: $\leq 0,76$ micron Ra – SF3.

External: Satin bead blast finish – 1,6 micron Ra.

Other surface conditions see IS PV20.00 E – Technical information.

OPTIONS: Different kinds of connections and dimensions.

USE: Steam, compressed air and other gases (Group 2).

AVAILABLE MODELS: ISC20I – 1.4404 (AISI 316L).

RETENTION RATES: 1, 5 and 25 micron.

SIZES: 1/4" to 2" threaded.
DN 10 to DN 80 flanged.

PIPE CONNECTIONS: Threaded BSP or NPT.
Flanged EN PN16 or ANSI class 150 lb.
Welded ends and other connections on request.

INSTALLATION: Horizontal installation always with the drain connection pointing downwards.
See IMI, installation and maintenance instructions.



CE MARKING (PED – European Directive)		
Ps 16 bar	PS 12 bar	Category
1/4" to 1 1/2" ; DN 10 to DN 40	/	SEP
2"L to 2 1/2" ; DN 50L to DN 65	/	1
/	3" ; DN 80	2

STEAM FILTER DATA INQUIRY	
Steam flow rate	kg/h
Saturated steam operating pressure	bar
Allowable pressure drop (0,07 bar max. recommended)	bar
Housing material	1.4301 or 1.4404
Size	DN
Pipe connections	BSP, Flanged PN16, ...
Filter element retention rate	1, 5 or 25 micron

LIMITING CONDITIONS		
Maximum allowable pressure	DN 10 to 65	16 bar
	DN 80	12 bar
Maximum allowable temperature	200 °C	
Minimum allowable temperature	- 20 °C	
Maximum operating pressure	EPM	8,5 bar @ 178 °C
	FLUORAZ	10 bar @ 200 °C
Minimum operating temperature	0 °C	
Maximum differential pressure	5 bar	
Maximum cold hydraulic	DN 10 to 65	20,8 bar
	DN 80	15,6 bar

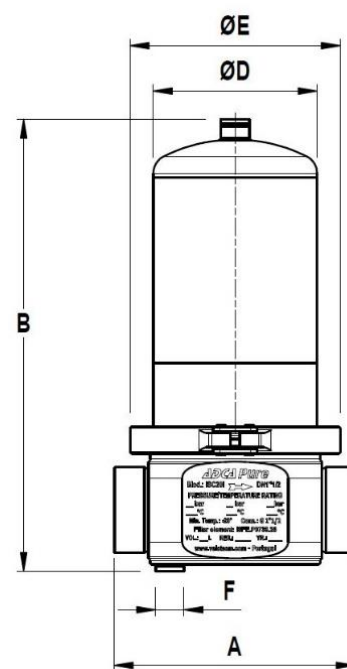
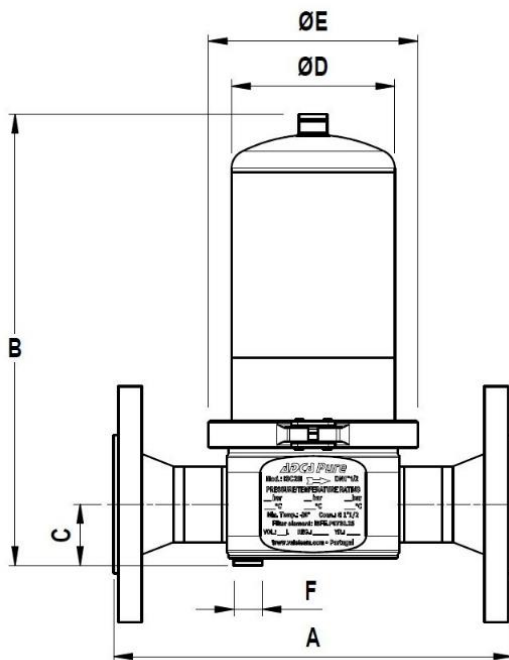

APPROXIMATE DIMENSIONS (mm)											
SIZE a)	A Screwed	A Tube weld	A Flanged PN16	A Flanged 150 lb	B	C	D	E	F	VOL. * (L)	WGT. ** (kg)
1/4"–DN 08	99	99	/	/	143	22,5	70	104	1/4"	0,34	3,3
3/8"–DN 10	101	101	180	/	173	22,5	70	104	1/4"	0,45	4,6
1/2"–DN 15	107	107	180	203	180	24,5	70	104	1/4"	0,48	4,9
3/4"–DN 20	130	130	202	230	210	27,5	70	118	1/4"	0,88	7,2
1"–DN 25	136	136	212	247	217	30,5	85	118	1/4"	0,94	7,7
1 1/4"–DN 32	142	142	220	254	279	36	85	118	1/4"	1,05	9,7
1 1/2"–DN 40	154	154	254	294	287	39	104	133	1/4"	2,12	11,4
2" L–DN 50L	163	163	260	297	374	45,5	104	133	1/4"	2,79	13,8
2" H–DN 50H	163	163	260	297	501	45,5	104	133	1/4"	3,81	14,6
2 1/2"–DN 65	/	216	306	356	644	52	129	170	1/4"	8,11	22,5
3" L–DN 80L	/	240	340	380	924	59	154	198	1/4"	16,7	35,4
3" H–DN 80H	/	240	340	380	924	59	154	198	1/4"	16,7	35,4

a) Suffix L corresponds to low capacity design; suffix H corresponds to high capacity.

* Volume corresponds to class PN16 design. ** Weight corresponds to PN16 design.

Consult factory for certified dimensions. Dimensions subject to change without notice.

MATERIALS		
POS. N°	DESIGNATION	MATERIAL
1	Filter housing	AISI 316L / 1.4404
2	Filter housing cover	AISI 316L / 1.4404
3	*Seal	PTFE / TFM® Envelope gasket
4	Closing ring	AISI 304 / 1.4301
5	*Filter element	Sintered AISI 316L
	Filter end caps	AISI 304 / 1.4301
6	* Filter seal o-rings (2)	EPDM, EPM, FLUORAZ
7	Gasket	PTFE
8	Plug	AISI 304 / 1.4301

* Available spare parts.

FDA / USP Class VI seals certificates on request.

All filters have a serial number. In case of non-standard filters this number must be supplied if spare parts are ordered.

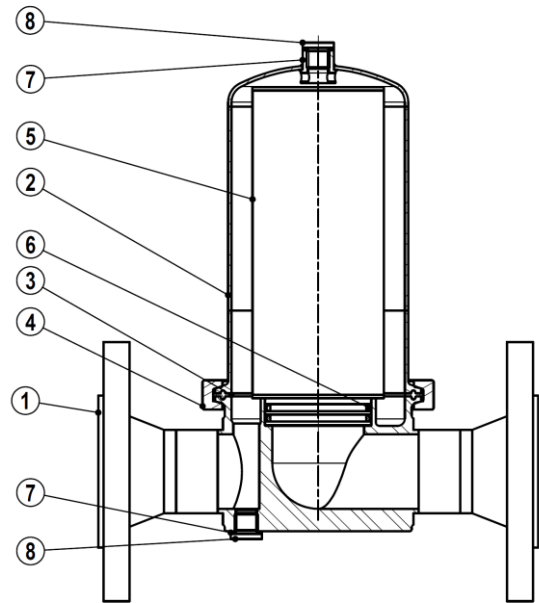

TYPICAL INSTALLATION – FILTERED STEAM PRESSURE REDUCING STATION

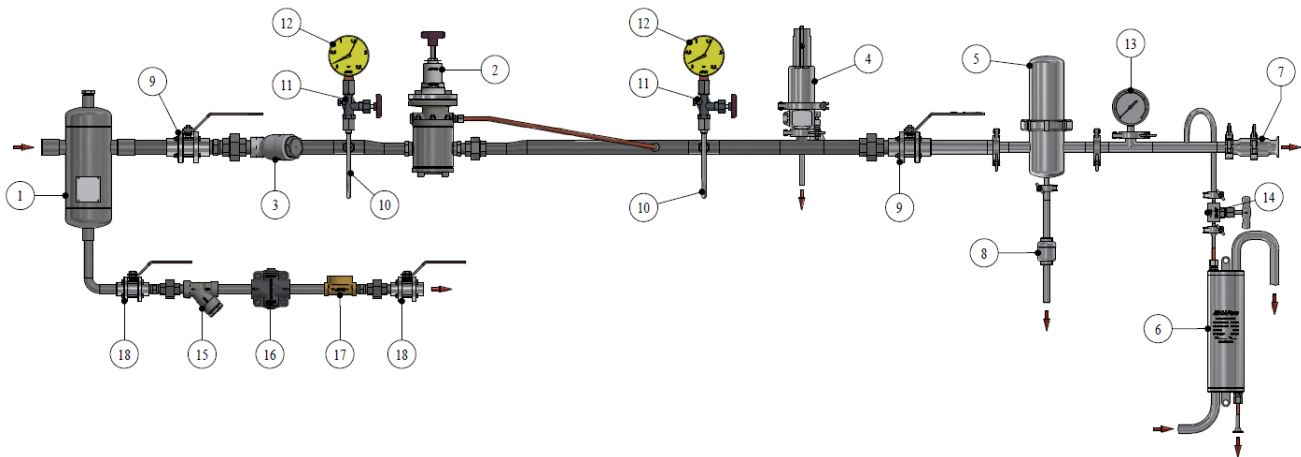

MATERIALS			
POS. N°	DESIGNATION	POS. N°	DESIGNATION
1	ADCA S16S Steam centrifugal humidity separator	10	ADCA GSU Gauge siphon
2	ADCA PRV47 Pilot operated pressure regulator	11	ADCA GC400 Gauge cock
3	ADCA IS140 Y Strainer	12	ADCA MAN100 Pressure gauge
4	Safety valve	13	ADCAPure SMAN-63R Pressure gauge
5	ADCAPure Culinary steam filter	14	ADCAPure NV400P Sanitary needle valve
6	ADCAPure SC32P Sample cooler	15	ADCA IS140 Y Strainer
7	ADCAPure SRT10	16	ADCA FLT17 Float and thermostatic steam trap
8	ADCA TSS22 Steam trap	17	ADCA SW12 Sight glass
9	ADCA M3i1 Three piece ball valve	18	ADCA M3S1 Three piece ball valve

ORDERING CODES – ISC20I FILTER HOUSING							
Filter model	ISC20I	.	T	A	.	08	
ISC20I Filter housing AISI 316L – 1.4404	ISC20I	.					
Housing seal material							
PTFE / TFM (Envelope gasket)			T				
Pipe connection							
Threaded BSP ISO 7/1 Rp				A			
Threaded NPT ANSI B1.20.1				C			
Tube weld				H			
Flanged EN1092-1 PN16				L			
Flanged ANSI B16.5 150 lb				U			
Size							
1/4" or DN 08						08	
3/8" or DN 10						10	
1/2" or DN 15						15	
...						...	
2"L or DN 50L						50L	
2"H or DN 50H						50H	
...						...	
Special / Extras a)							E

a) Full description or additional codes have to be added in case of non-standard combination.

ORDERING CODES – FILTER ELEMENT							
Filter element model	ISFE	.	P	0310	.	01	
ISFE Filter element AISI 316L – 1.4404	ISFE	.					
Filter to housing sealing o-rings							
Without sealing o-rings			X				
EPDM (up to 180 °C)			E				
EPM (up to 180 °C)			P				
FLUORAZ (up to 200 °C)			F				
Filter size according to housing DN connection							
1/4" or DN 08				0310			
3/8" or DN 10				0410			
1/2" or DN 15				0420			
3/4" or DN 20				0520			
1" or DN 25				0525			
1 1/4" or DN 32				0725			
1 1/2" or DN 40				0730			
2"L or DN 50L				1030			
2"H or DN 50H				1530			
2 1/2" or DN65				2030			
3"L or DN 80L				3030			
3"H or DN80H				3050			
Retention rate							
1 micron						01	
5 micron						05	
25 micron						25	
Special / Extras b)							E

b) Full description or additional codes have to be added in case of non-standard combination.

Order example:

1 Adcapure filter housing ISC20I PTFE / TFE seals 2"L threaded BSP 2" Code: ISC20I.TA.50L

1 ISFE filter element with 5 micron retention rate for the above mentioned filter Code: ISFE.P1030.05

Note: we recommend a second filter element as a spare part to ensure a minimum downtime when replacing the one in use after saturation.