

HYGIENIC BALL VALVES M3H FULL BORE (6" ASME BPE)

DESCRIPTION

M3H three piece body ball valves are isolating valves designed for use with clean steam, condensate and other gases and liquids used in high purity and aseptic processes. The valve is not designed as a control valve and should only be used as an isolating valve, fully open or fully closed. The product is mainly designed for the pharmaceutical, biotech, semiconductor, cosmetics, fine chemical, food and beverage industries.

MAIN FEATURES

Full bore floating ball design.
A351 CF3M body and ends with ferrite content of less than 2% and low sulphur between 0,005 and 0,017%.
Can be serviced without removal from pipeline.
Bidirectional.
Anti blow out proof stem.
ISO 5211 mounting.

STANDARD SURFACE FINISH

Internal wetted parts: $\leq 0,51$ micron Ra – SF1.
External: as casted.
Ultrasonic cleaning.

OPTIONS: Antistatic device.
Different sealing materials.
Degreased for oxygen use.
Tube weld with loose body flanges (360° rotation after installation).
Cavity filler.

USE: Clean steam, gases and liquids compatible with the construction.

AVAILABLE MODELS: M3H – Investment casting.

SIZES: 6".

CONNECTIONS: According to ASME BPE.
TC – Sanitary clamps.
ETO – Extended tube orbital welding.
TC / ETO – Combination.

PACKAGING: Assembling and packaging in a clean room certified according to ISO 14644-1.
The product is end capped and sealed with recyclable thermo-shrinkable plastic film, to avoid contamination.

INSTALLATION: See IMI, installation and maintenance instructions.



CE MARKING (PED – European Directive)	
PN16	Category
DN 150	1 (CE Marked)

MATERIALS		
POS. N°	DESIGNATION	MATERIAL
1	Valve body	CF3M / 1.4409
2	TC end connection	CF3M / 1.4409
3	Tube weld end conn.	CF3M / 1.4409
4	Stem	AISI 316L / 1.4404
5	* Valve ball	AISI 316L / 1.4404
6	* Standard seat	TFM 1600
7	* Cavity filler seat	TFM 1600
8	Body ring	AISI 316L / 1.4404
9	* Body seal	PTFE
10	* Stem seals	TFM 1600
11	* Stem thrust seal	TFM 1600 - PEEK
12	* Spacer	AISI 316 / 1.4401
13	Spring washer	AISI 304 / 1.4301
14	Compression nut	AISI 304 / 1.4301
15	* Lock washer	AISI 304 / 1.4301
16	Fixing screw	AISI 304 / 1.4301
17	Handle stopper pin	AISI 304 / 1.4301
18	Handle stopper	AISI 304 / 1.4301
19	Handle fixing bolt	AISI 304 / 1.4301
20	Handle	AISI 304 / 1.4301
21	Bracket	AISI 304 / 1.4301
22	Bracket stem	AISI 304 / 1.4301
23	Bracket bolts	AISI 304 / 1.4301
24	Gearbox	Cast iron

* Available spare parts.

Remarks: FDA / USP class VI seals certificate on request.

All valves have a serial number. In case of non-standard valves this number must be supplied if spare parts are ordered.

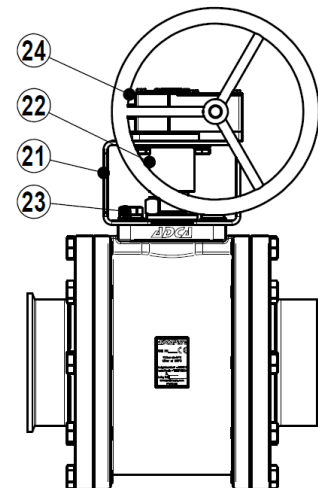
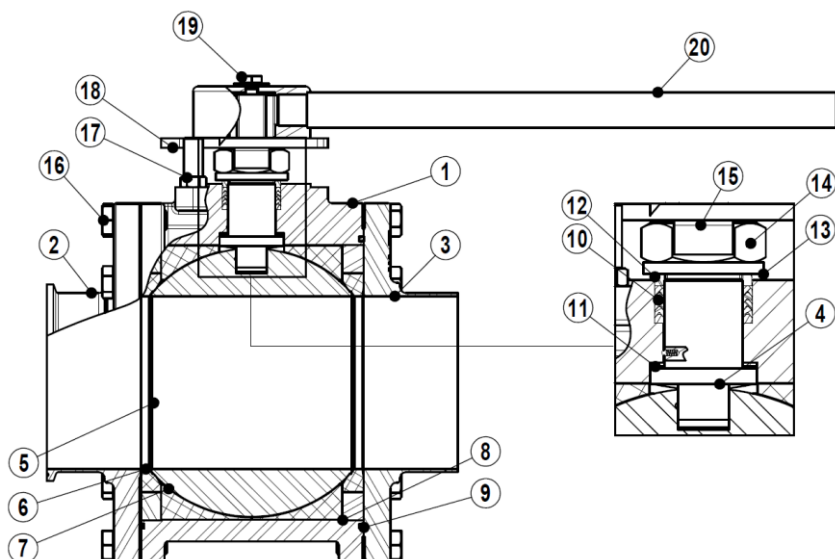
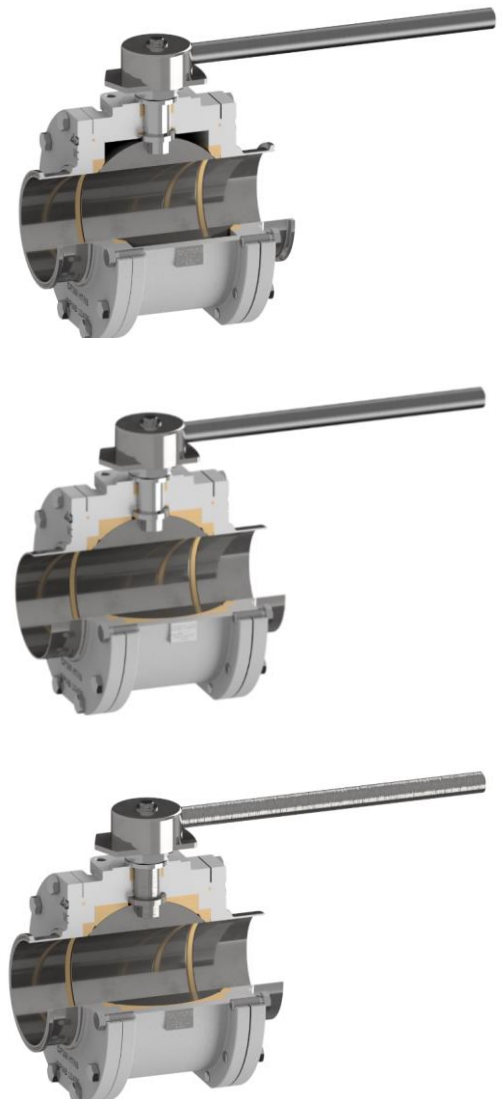

DIMENSIONS (mm) ASME BPE

SIZE	A1	A2	A3	A3.1	A3.2	B	C	D	D1	E	ØF	ØG	ØH	I	J	L	M	ØN	BALL PORT	ISO 5211	WGT. (kg)
6"	350	350	350	175	175	324	153	260	166	500	167	152	147	48	101	63	164	250	152,4	F14	94,9

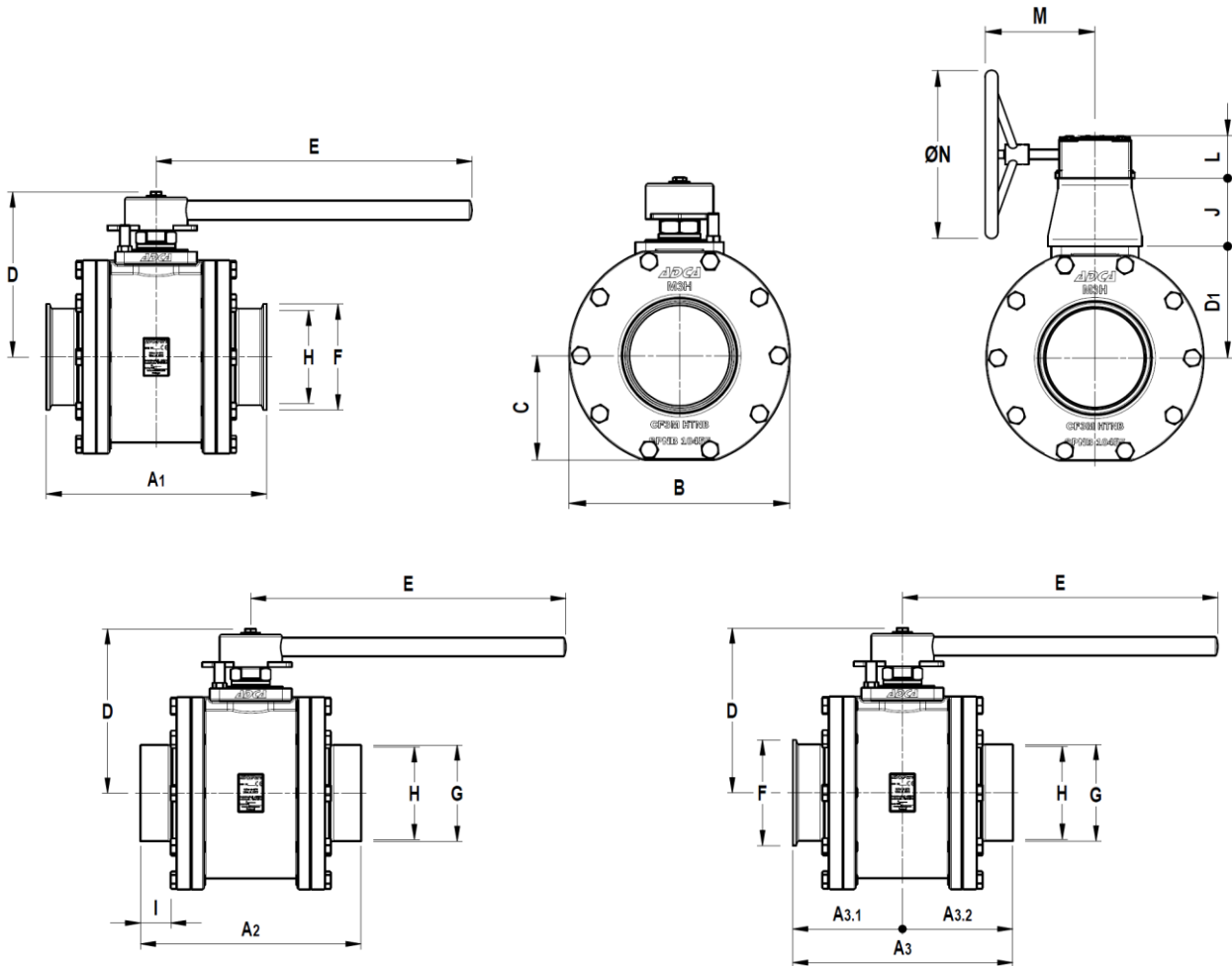

Tube weld easy and quick installation - optional

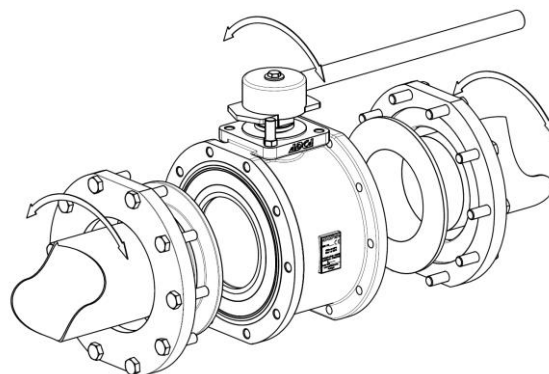

Loose body flanges make it possible to install the valve without aligning of welded end connections. After installation the valve can rotate on 360° for the desired orientation.

ORDERING CODES M3H											
Valve model		MH	.			F	F			CB	150
M3H 3 pieces ball valve CF3M		MH									
Lever handle											
Flat lever handle stainless steel / plastic cover											(*)
Flat lever handle stainless steel / plastic cover w/ lockable system											3
Bare stem											9
Material											
CF3M / 1.4409											(*)
Seat design											
Standard seats											(*)
Cavity fillers						F					
Seat material											
TFM 1600							F				
Surface finish, special services and options											
Standard surface finish (mechanical polishing)											(*)
Electropolishing											1
Oxygen cleaning											2
Antistatic device											
None											(*)
Antistatic device											A
End connections											
TC – Sanitary clamps ASME BPE										CB	
ETO – Extended tube orbital welding ASME BPE (360° rotation)										TB	
TC / ETO Combination ASME BPE (360° rotation)										CTB	
Ball port											
Full bore (standard)											(*)
True bore											NA
Size											
6"											150
Special valves / Extras											
Full description or additional codes have to be added in case of a non standard combination											E

(*) Omitted if a standard valve is requested.
 NA – Not available.