

HIGH ACCURACY PRESSURE REDUCING VALVE PRV300 1 1/2" – 2"; DN 40 – DN 50

DESCRIPTION

The ADCA PRV300 series direct acting, spring-loaded diaphragm sensing, balanced plug pressure reducing valves, are designed for use on compressed air, water and other gases or liquids compatible with the materials of construction.

They are suitable for high accuracy pressure reducing stations at the point of use on laundry machines, dyeing, food industries, sterilizers, etc.

Connections are female screwed or flanged.



MAIN FEATURES

- Compact design.
- Large high accuracy diaphragm.
- Balanced valve plug.
- Machined from barstock materials and investment casting.

- OPTIONS:**
- Different soft valves for water and gases.
 - Relieving – Internal relief valve to allow reduced outlet pressure in a no-flow condition.
 - Built-in strainer.
 - Outlet 1/4" gauge connection on body.
 - Regulating screw with top cap.

- USE:** Compressed air, water and other gases and liquids compatible with the construction.

- AVAILABLE MODELS:** PRV300/SS – Stainless steel.

- SIZES:** 1 1/2" and 2".
DN 40 and DN 50.

- CONNECTIONS:** Female screwed ISO7/1Rp (BS 21).
Flanged EN 1092-1 PN40 or ANSI.

- INSTALLATION:** Horizontal installation.
An "Y" strainer should be installed upstream the valve.
See IMI – Installation and maintenance instructions.

- ORDER REQUIREMENTS:** Type of fluid.
Maximum operating temperature.
Inlet pressure and required outlet pressure.
Capacity (maximum and minimum).

CAPACITIES		
Valve size	1 1/2" – DN 40	2" – DN 50
Kvs (m ³ /h)	12,7	13,7

LIMITING CONDITIONS	
Valve model	PRV300
Body design conditions	PN16
Max. upstream pressure	16 bar
Max. downstream pressure	1,7 bar
Min. downstream pressure	0,05 bar
Max. design temperature *	80 °C
Max. recommended reducing ratio	40:1

* Others on request.

CE MARKING – GROUP 2 (PED – European Directive)	
PN16	Category
1 1/2" to 2" – DN 40 to 50	SEP

DIMENSIONS (mm)								
Screwed					PN16			
SIZE	A	B	C	D	WGT. (kg)	E	F *	WGT. (kg)
1 1/2" - DN 40	195	90	305	270	23,2	75	320	28
2" - DN 50	205	90	305	270	23,6	82,5	320	28,7

* Different lenghts on request.

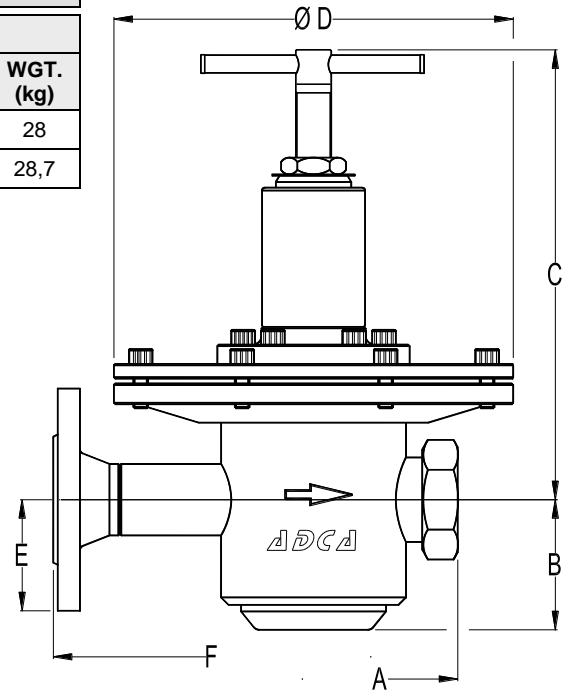

MATERIALS		
POS. Nº	DESIGNATION	MATERIAL
1	Valve body	AISI 316 / 1.4401 ; CF8M / 1.4408
2	Cover	AISI 316 / 1.4401
2A	Spring cover	AISI 316 / 1.4401 ; CF8M / 1.4408
2B	Bolts	Stainless steel A2-70
3	Seat cover	AISI 316 / 1.4401
4	* O-ring	NBR
5	* Piston valve	AISI 316 / 1.4401
6	* Valve head	NBR
6A	* Pushrod	AISI 316 / 1.4401
7	* O-ring	NBR
8	* Valve spring	Spring steel
9	Pusher disc	AISI 304 / 1.4301
10	* Diaphragm	Rubber
13	Spring plate	AISI 304 / 1.4301
14	Nut	Stainless steel A2-70
15	* Adjustment spring	Steel
16	Top spring plate	Brass
17	Adjustment screw	AISI 304 / 1.4301
18	Locknut	Stainless steel A2-70
20	Spring Id. plate	Aluminium

* Available spare parts.

Remarks: All valves have a serial number. In case of non-standard valves this number must be supplied if spare parts are ordered.

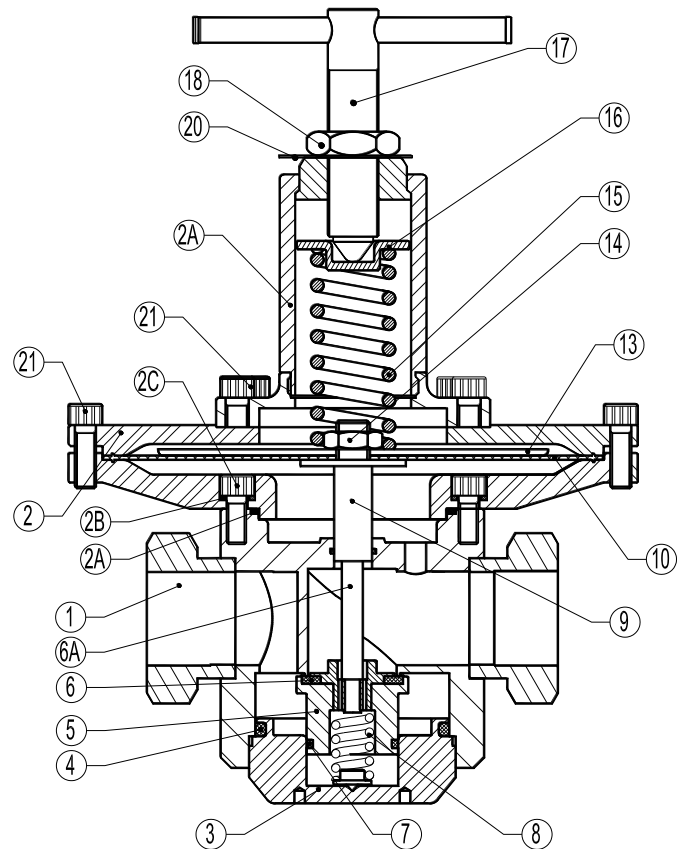

ORDERING CODES PRV300SS													
Valve model	R300	.	1	W	N	B	R		.			15	
PRV300SS – Diaphragm sensing	R300												
Outlet spring range													
N° 1 – 0,05 to 0,3 bar				1									
N° 2 – 0,2 to 1,7 bar				2									
Application													
Water				W									
Gases				G									
Oxygen (degreased)				O									
Seal material													
NBR					N								
EPDM					E								
PTFE					T								
FPM / Viton					V								
Maximum inlet pressure													
16 bar						B							
Diaphragm material													
Rubber /PTFE (Relieving or non-relieving)							R						
Gauge port 1/4"													
Without gauge ports								(1)					
Gauge port on the left side (relative to the flow direction)								4					
Gauge port on the right side (relative to the flow direction)								3					
Gauge ports on both sides								2					
Relieving													
Non-relieving								(1)					
Relieving (for non-dangerous gases only)								R					
Pipe connection													
Threaded BSP ISO 7/1 Rp												A	
Threaded NPT ANSI B1.20.1													C
Socket weld SW ANSI B16.11													H
Butt weld BW ANSI B16.25													I
Flanged EN 1092-1 PN40													N
Flanged EN 1092-1 PN63													O
Flanged ANSI B16.5 150 lb													U
Flanged ANSI B16.5 300 lb													V
Flanged ANSI B16.5 600 lb													W
Size													
1 1/2" or DN 40													40
2" or DN 50													50
Special valves / Extras													
Full description or additional codes have to be added in case of non-standard combination.												E	

(1) Omitted if a standard valve is requested.