

**PISTON SENSING PRESSURE REDUCING VALVE
PRV31SS
1/2" – 3/4" ; DN 15 – DN 20**

DESCRIPTION

The ADCA PRV31 series direct acting, spring-loaded piston sensing, balanced plug pressure reducing valves, are designed for use on compressed air, water and other gases or liquids compatible with the materials of construction.

They are suitable for pressure reducing stations at the point of use on laundry machines, dyeing, food industries, sterilizers, etc.

Connections are female screwed or flanged.

MAIN FEATURES

Compact design.
Balanced valve.
Machined from barstock materials or investment casting.

OPTIONS: Different soft valves for water and gases.
Relieving – Internal relief valve to allow reduced outlet pressure in a no-flow condition.
Built-in strainer.
Outlet 1/4" gauge connection on body.
Regulating screw with top cap.

USE: Compressed air, water and other gases and liquids compatible with the construction.

AVAILABLE MODELS: PRV31SS – Stainless steel.

SIZES: 1/2" and 3/4".
DN 15 and DN 20.

CONNECTIONS: Female screwed ISO7/1Rp (BS 21) or NPT.
Flanged EN 1092-1 PN40 – PN63.
Special flanges upon request.
Horizontal installation.

INSTALLATION: An "Y" strainer should be installed upstream of the valve.
See IMI – Installation and maintenance instructions.
Type of fluid.

ORDER REQUIREMENTS: Maximum operating temperature.
Inlet pressure and required outlet pressure.
Capacity (maximum and minimum).



CE MARKING – GROUP 2 (PED – European Directive)	
PN16 / PN63	Category
DN 15 to 20	SEP

CAPACITIES		
Valve size	1/2" – DN 15	3/4" – DN 20
Kvs (m ³ /h)	3	3,5

LIMITING CONDITIONS	
Valve model	PRV31SS
Body design conditions	PN63
Max. upstream pressure	50 bar
Max. downstream pressure	50 bar
Min. downstream pressure	3 bar
Max. design temperature *	80 °C
Max. recommended reducing ratio	40:1

* Other on request.

DIMENSIONS (mm)										
SIZE	Screwed				PN16/40			PN63/100		
	A	B	C	WGT. (kg)	D *	E	WGT. (kg)	D *	E	WGT. (kg)
1/2" – DN 15	80	38	175	2,6	150	47,5	4	210	52,5	4,9
3/4" – DN 20	80	38	175	2,6	150	52,5	4,7	230	70	6,9

* Different lengths on request.

Remarks: DN 15 PN16/40 face to face dimensions adopted as per DN 20.

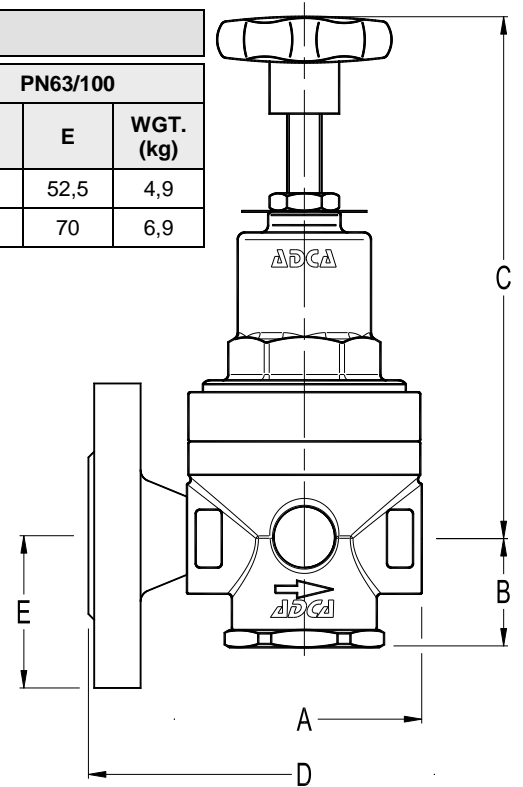

MATERIALS		
POS. Nº	DESIGNATION	MATERIAL
1	Valve body (a)	CF8M / 1.4408 (AISI 316 / 1.4401)
1A	Piston sleeve	AISI 316 / 1.4401
2	Top cover (a)	CF8M / 1.4408 (AISI 316 / 1.4401)
3	Seat cover (a)	CF8M / 1.4408 (AISI 316 / 1.4401)
4	* O-ring	NBR
5	* Piston valve	AISI 316 / 1.4401
6	* Valve head	NBR ; EPDM ; PTFE ; etc.
6A	Pushrod	AISI 316 / 1.4401
7	* O-ring	NBR ; EPDM ; PTFE ; etc.
8	* Valve spring	AISI 302 / 1.4300
8A	* Strainer screen	AISI 304 / 1.4301
9	Piston	AISI 316 / 1.4401
9A	* O-ring	NBR ; EPDM ; PTFE ; etc.
11A	* O-ring	NBR ; EPDM ; PTFE ; etc.
12	Gasket	Aluminium
13	Spring plate	AISI 304 / 1.4301
15	* Adjustment spring	Spring steel
16	Top spring plate	Brass
17	Adjustment screw	AISI 304 / 1.4301
18	Locknut	Stainless steel A2 – 70
19	Handwheel	Plastic
20	Spring id. plate	Aluminium

* Available spare parts.

Remarks: All valves have a serial number. In case of non standard valves this number must be supplied if spare parts are ordered.

(a) Bar stock execution on request.

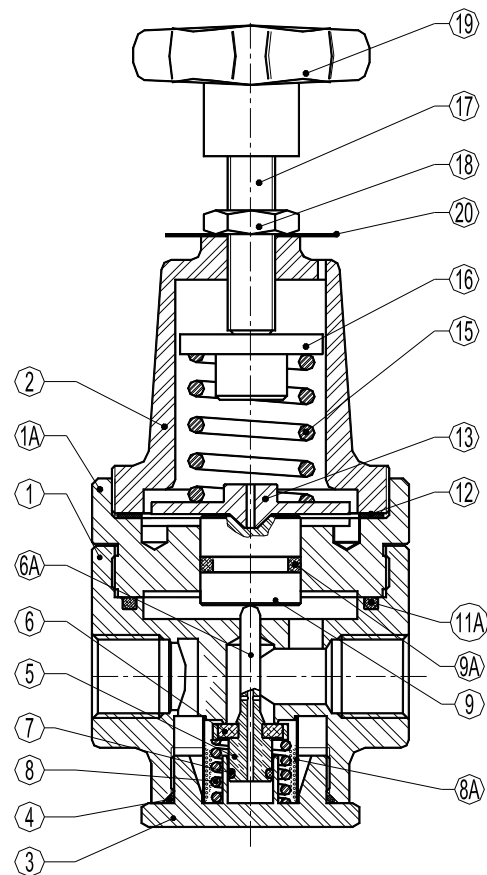

ORDERING CODES PRV31SS												
Valve model	R31	.	5	W	N	C		.	A	15		
PRV31SS – Piston sensing	R31											
Outlet spring range												
N°5 – 3 to 30 bar				5								
N°6 – 5 to 50 bar				6								
Application												
Water				W								
Gases				G								
Oxygen (degreased)				O								
Seal material												
NBR					N							
EPDM					E							
PTFE					T							
FPM / Viton					V							
Maximum inlet pressure												
30 bar						C						
50 bar						D						
Gauge port 1/4"												
Without gauge ports									(1)			
Gauge port on the left side (relative to the flow direction)									4			
Gauge port on the right side (relative to the flow direction)									3			
Gauge ports on both sides									2			
Relieving												
Non-relieving									(1)			
Relieving (only for non dangerous gases)									R			
Pipe connection												
Threaded BSP ISO 7/1										A		
Threaded NPT ANSI B1.20.1										C		
Socket weld SW ANSI B16.11										H		
Butt weld BW ANSI B16.25										I		
Flanged EN 1092-1 PN40										N		
Flanged EN 1092-1 PN63										O		
Flanged ANSI B16.5 150 lb										U		
Flanged ANSI B16.5 300 lb										V		
Flanged ANSI B16.5 600 lb										W		
Size												
1/2" or DN 15											15	
3/4" or DN 20											20	
Special valves / Extras												
Full description or additional codes have to be added in case of non-standard combination.												E

(1) Omitted if a standard valve is requested.