

## PILOT OPERATED PRESSURE REDUCING VALVES PRV47/2 DN 65 – DN 100

### DESCRIPTION

The ADCA PRV47/2 pilot operated pressure reducing valves are designed for use with steam, compressed air, nitrogen and other gases compatible with the construction materials. The PRV47/2 can be installed in pressure reducing stations throughout all industries, and provides sensitive and accurate control even when inlet pressure fluctuations or flow variations occur.

### MAIN FEATURES

Robust complete carbon steel construction.  
Suitable for dead end conditions.  
Guided piston and valve stem.  
Hardened plug.

**OPTIONS:** Soft faced valve plug for gases and steam.  
Special pressure top for low pressures.  
Stellited plug and seat.  
Balance pipe connected to the valve body.

**USE:** Saturated steam, compressed air and other gases (Group 2) compatible with the construction (except oxygen).

**AVAILABLE MODELS:** PRV47/2 – standard model for steam.  
PRV47/2G – compressed air and gases.

**VALVE SIZES:** DN 65 to DN 100.

**CONNECTIONS:** Flanged EN 1092-1.

**INSTALLATION:** Horizontal installation.  
An “Y” strainer, steam separator and steam trap should be installed upstream the valve.  
See IMI – Installation and maintenance instructions.  
Typical assembling drawing available.  
Special assembling design may be produced on request.

### ORDER

**REQUIREMENTS:** Type of fluid.  
Maximum operating temperature.  
Inlet and outlet pressure.  
Flow rate (maximum and minimum).



### USEFUL NOTES ON VALVE AND PIPE SIZING

A special low top assembly should be fitted for outlet pressures from 0,07 up to 0,5 bar (fig.2).  
Two regulators in parallel should be used on larger systems where minimum flow is less than 10% of maximum. If the flow is unknown it is possible to estimate it based on pipe sizing or equipment heat requirement – please consult.  
The balance pipe connection is recommended to enter the downstream pipe at a minimum of 1 meter from the valve. A spool piece can be supplied to house the balancing pipe.  
**HOW TO SELECT:** Never size the valve according to the pipe diameter in which it has to be fitted, but according to the required actual flow of fluid.  
Refer to valve calculation table or consult factory.

VALVE BODY LIMITING CONDITIONS		
PN16 *	PN40 *	RELATED TEMP.
ALLOW. PRESS.	ALLOW. PRESS.	
16 bar	40 bar	-10 / 50 °C
13,3 bar	33,3 bar	200 °C
12,1 bar	30,4 bar	250 °C
11 bar	27,6 bar	300 °C

\* Rating according to EN1092-1.

CE MARKING – GROUP 2 (PED – European Directive)		
PN16	PN40	Category
DN 65 to 100	DN 65 to 100	1 (CE Marked)

LIMITING CONDITIONS		
Body design conditions	PN16	PN40
Max. upstream pressure	13 bar	28 bar
Max. downstream pressure	13 bar	17 bar
Min. downstream pressure *	0,35 bar	0,35 bar
Max. operating temperature	250 °C	250 °C
Max. reducing ratio	See capacity table	
Rangeability	10:1	10:1
Max. cold hydraulic test	17 bar	17 bar
Max. hydraul. factory valve body test	24 bar	60 bar

\* 0,07 bar w/ low press. top (limited at 7 bar inlet).  
Pressure and temperature may change if soft sealing or soft piston rings are used.

**MATERIALS – PRV47/2 Carbon steel construction**

POS. Nº	DESIGNATION	MATERIAL
1	Valve body	ASTM A216WCB / 1.0619
1A	Piston housing	ASTM A216WCB / 1.0619
1B	Stem guide	Bronze B62 / ASTM B148.97
1C	* Gasket	Stainless steel / Graphite
1D	* Plain bearing	Bronze
2	Pilot valve body	CF8 / 1.4308
2A	Pilot valve body	CF8 / 1.4308
3	Top cover	CF8 / 1.4308
3A	Cover spring	CF8 / 1.4308
3B	Top cover	CF8 / 1.4308
3C	Cover nut	C45E / 1.1191
4	* Main valve seat	AISI 316 / 1.4401
5	* Main valve	Hardened stainless steel
5A	* Main valve (soft)	SS316 w/ PTFE/GR; Rulon
5B	* Valve stem	AISI 316 / 1.4401
5C	* Ball	AISI 440C / 1.4125
5D	* Plain bearing	Bronze
5E	* Spring pin	AISI 304 / 1.4301
6	* Main valve spring	AISI 302 / 1.4300
7	* Piston	Bronze B62 / ASTM B148.97
8	* Piston rings	Bronze / KFM / EPDM / NBR
9	Piston liner	AISI 304L / 1.4306
9A	* Gasket	Stainless steel / Graphite
10	Bottom cover	C45E / 1.1191
11	* Bottom cover gasket	Stainless steel / Graphite
12	* Diaphragm	AISI 301 / 1.4310
12A	* Low pressure diaphragm	AISI 301 / 1.4310
13	* Diaphragm gasket	Stainless steel / Graphite
13A	* Diaphragm gasket	Stainless steel / Graphite
14	* Pilot valve gasket	Stainless steel / Graphite
15	Lower spring carrier	Brass
16	* Adjustment spring	Steel
16A	Diaphragm spring	Stainless steel / Graphite
16B	* O-ring	EPDM
17	Top spring carrier	Brass
18	Locknut	AISI 304 / 1.4301
19	* Push rod	AISI 316 / 1.4401
19A	* Pilot valve (soft)	PTFE/GR; Rulon, etc.
20	* Pilot valve plug	Hardened stainless steel
20A	* Pilot valve seat	AISI 316 / 1.4401
21	* Pilot valve gasket	Copper
22	* Pilot valve spring	AISI 302 / 1.4300
24	Bolts	Steel 10.9
24C	Bolts	Steel 10.9
25	Compression fitting	Plated carbon steel
26	Balance pipe	Copper
27	Pilot valve strainer screen	AISI 304 / 1.4301
28	* Strainer nut	AISI 304 / 1.4301
29	Gasket	Copper
30	Studs	34CrNiMo6 / 1.6582
31	Nuts	Steel Cl.8
46	Spring id. plate	Aluminum
48	Handwheel	Plastic / Stainless steel
100	** Pressure regulator (relieving)	ADCA P10
105	Solenoid valve	Brass
107	* Strainer	ADCA IS100I (Stainless steel)

\* Available spare parts.

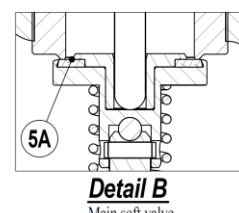
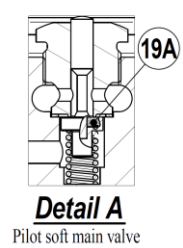
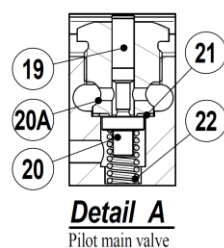
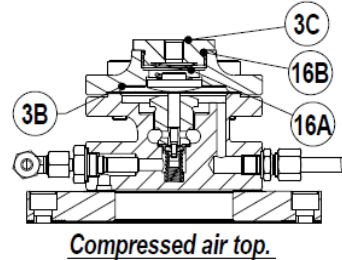
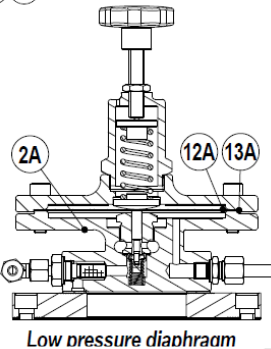
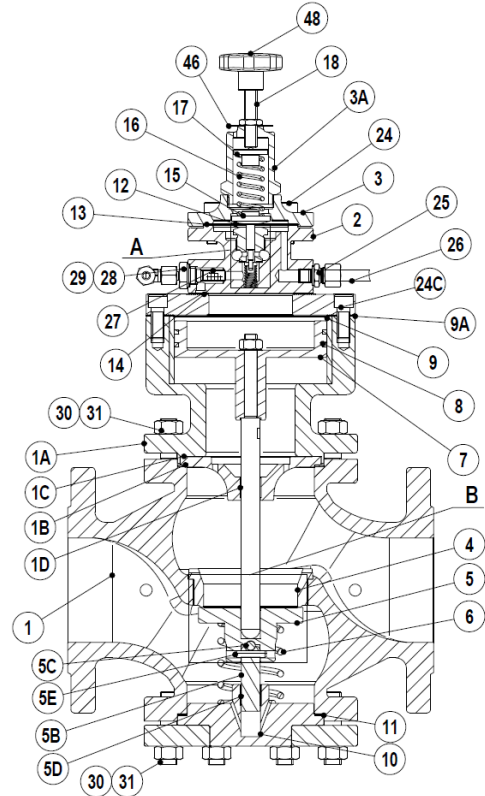

PRESSURE RANGES (bar)				
SPRING COLOUR	GREEN w/ 1 diaphragm	BLUE w/ 1 diaphragm	RED w/ 2 diaphragms	BLACK w/ 2 diaphragms
Red. Pressure	0,07 to 0,5 bar *	1,5 to 5,5 bar **	3,5 to 8,5 bar **	7 to 17 bar **
Red. Pressure	0,35 to 2 bar **	/	/	/

\* With low pressure top; \*\* Standard diaphragm.

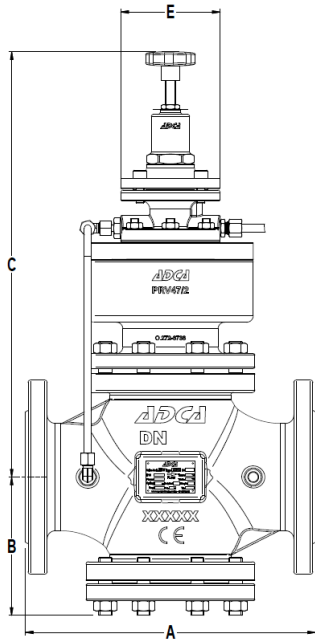

Fig. 1

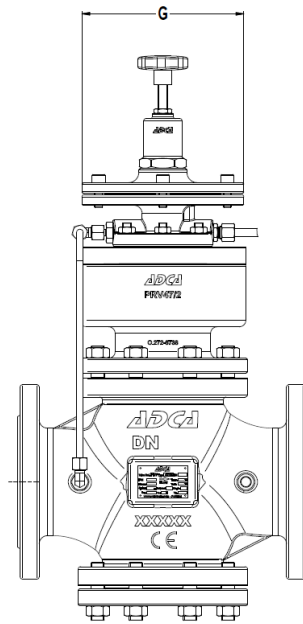

Fig. 2

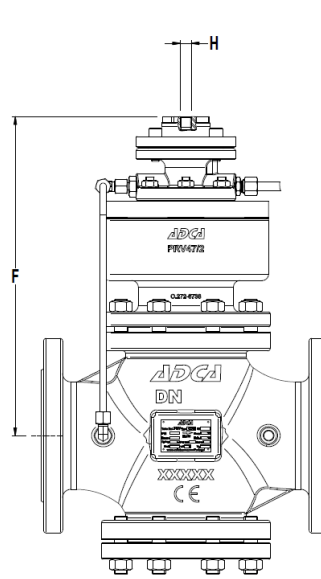

Fig. 3

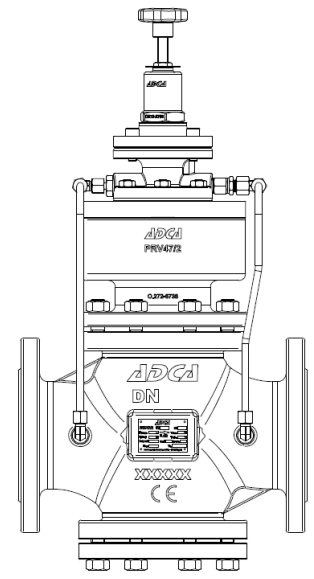

Fig. 4

Fig. 1 – Valve with standard diaphragm.  
Fig. 2 – Valve with low pressure top.

Fig. 3 – Valve with compressed air top.  
Fig. 4 – Valve with balance pipe on body.

DIMENSIONS – VALVE BODY (mm)								
DN	A	B	C	E	F	G	H	WEIGHT (kg)
65	290	150	470	120	340	195	1/4"	46,7
80	310	150	480	120	350	195	1/4"	56,7
100	350	168	515	120	386	195	1/4"	76,9

## EXAMPLE VERSIONS

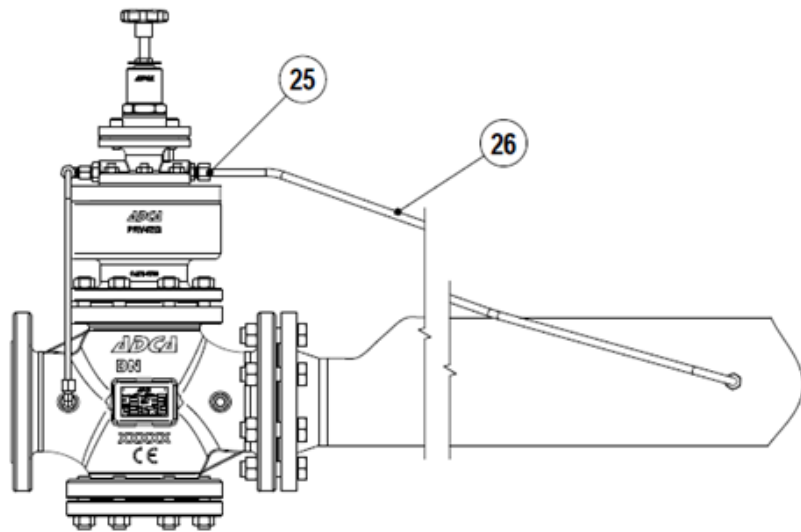

Fig.4

### PRV47/2 Standard for steam, compressed air or gases (Fig.4)

The high pressure upstream fluid enters the main valve and the pilot valve. By compressing the regulating spring over the diaphragm, the pilot valve opens, admitting regulated pressure to the piston chamber. The force exerted by the regulated pressure on top of the piston pushes it down, which in turn opens the main valve. The downstream pressure is then transmitted through the balance pipe, acting below the diaphragm.

Any downstream pressure increase deflects the diaphragm, and the pilot valve closes, thus shutting off regulated gas to the piston which in turn closes the main valve. When the correct downstream pressure is achieved, the valve opens again, repeating the process.

**Important:** the balance pipe (n° 26) must always be connected, unless the valve was supplied with the balance pipe connected to the valve body. However, the fitting of the balance pipe is still highly recommended when:

- The reduced pressure is below 55% of the inlet pressure (mandatory for pressure reductions greater than 10:1);
- Instability of reduced pressure occurs;
- When a low pressure top assembly is fitted.
- When difficult outlet pipe work conditions occur.

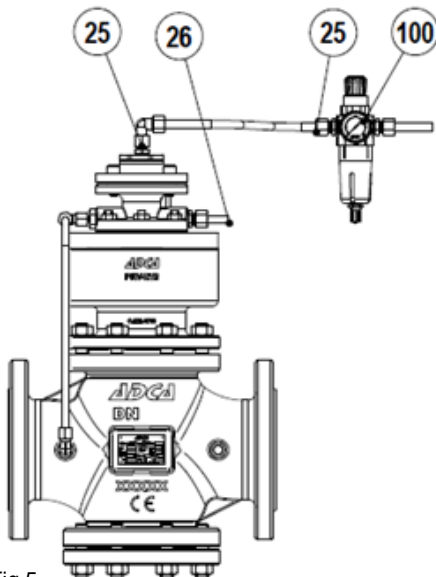

Fig.5

### PRV47/2 valve with compressed air top (air loaded pilot) (Fig.5)

The loading force is exerted on the pilot valve diaphragm by an external compressed air signal rather than by the regulating spring.

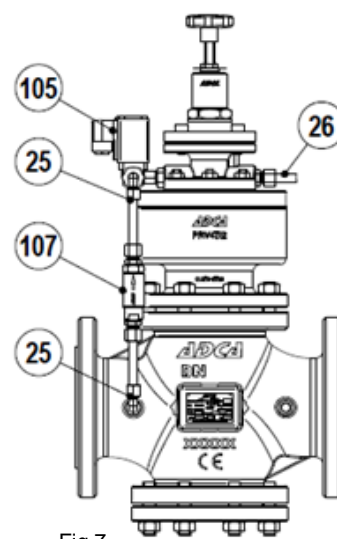

Fig.7

### PRV47/2E with solenoid valve for electric remote control (Fig.7)

This valve version operates like the standard valve but it allows a remote closing, by means of a switch or timer. When the solenoid valve closes, the pressure signal to the pilot valve is interrupted and thus the main valve also closes.

PRV47/2 – STEAM CAPACITY TABLE (kg/h)

INLET (barg)	OUTLET (barg)	SATURATED STEAM								
		DN 15	DN 20	DN 25	DN 32	DN 40	DN 50	DN 65	DN 80	DN 100
0,7	0,35	40	75	125	190	280	480	–	–	–
1	0,4	45	95	160	240	355	620	–	–	–
	0,6	40	83	140	210	308	535	–	–	–
2	0,4 ÷ 1	75	150	250	380	545	960	1490	1880	3390
	1,2	65	138	230	345	515	900	1335	1685	3022
	1,6	50	105	175	265	393	685	–	–	–
3	0,4 ÷ 1,5	100	200	335	510	750	1310	1980	2475	4358
	2	85	170	290	450	660	1155	1732	2175	3962
	2,2	80	165	277	416	613	1050	1585	1981	3616
	2,6	60	127	203	315	467	818	–	–	–
4	0,4 ÷ 2	125	250	420	630	920	1580	2530	3170	5696
	2,5	114	225	385	580	850	1465	2328	2923	5249
	3,2	92	183	309	482	708	1205	1735	2179	3913
	3,6	68	137	237	353	536	932	–	–	–
5	0,4 ÷ 2	150	310	512	755	1114	1895	3022	3765	6733
	3	144	295	488	743	1095	1835	2869	3615	6486
	4	115	225	373	578	846	1430	2130	2675	4852
	4,2	105	213	343	525	770	1342	–	–	–
6	0,4 ÷ 3	175	355	602	919	1358	2298	3566	4453	8021
	4	159	314	538	827	1217	2142	3219	4012	7229
	5	119	250	411	637	941	1644	2276	2870	5150
	5,2	109	217	360	568	839	1465	–	–	–
7	0,4 ÷ 3,5	197	410	670	1005	1540	2644	3959	4952	8911
	5	178	358	587	908	1345	2306	3513	4405	7921
	6	132	271	452	688	1027	1773	2764	3022	5416
	6,2	122	251	416	635	934	1618	–	–	–
8	0,4 ÷ 4	225	471	778	1169	1759	3043	4605	5745	10398
	5	221	339	730	1118	1659	2884	4305	5395	9704
	6	192	385	639	976	1451	2513	3761	4704	8467
	7	146	293	481	732	1085	1887	2727	3168	5695
	7,2	137	274	453	692	1011	1782	–	–	–
9	0,4 ÷ 5	251	518	856	1325	1923	3358	5051	6334	11387
	6	241	500	788	1222	1766	3095	4653	5794	10396
	7	206	398	679	1068	1559	2676	4060	5051	8961
	8	156	314	514	794	1142	2053	2671	3319	5991
	8,2	145	292	483	741	1090	1888	–	–	–
10	0,4 ÷ 5	275	561	944	1468	2127	3718	5592	7031	12377
	6	272	551	917	1419	2074	3619	5443	6830	12270
	7	252	508	838	1268	1871	3249	4951	6187	10891
	8	213	431	722	1118	1659	2831	4108	5149	9209
	9	163	333	548	843	1244	2152	2721	3466	6190
	9,2	150	298	493	756	1143	1929	–	–	–
12	1 ÷ 6	330	680	1124	1732	2541	4407	6631	8216	14850
	8	311	629	1023	1575	2332	4034	6090	7573	13862
	10	265	533	812	1271	1867	3202	4503	5592	9903
	11	175	364	568	924	1350	2359	2920	3612	6536
15	1 ÷ 8	408	839	1373	2138	3118	5403	8164	10393	18317
	12	339	656	1068	1629	2441	4250	6385	7986	14356
	14	199	401	662	1017	1503	2619	2968	3661	6438
17	1 ÷ 9	425	863	1460	2178	3165	5343	9204	11360	20290
	15	347	709	1190	1816	2694	4712	5870	7363	14855
	16	207	416	717	1217	1608	2824	3598	4312	6330
20	1 ÷ 12 (2÷12)*	541	4062	1774	2746	4001	6971	10390	13363	23765
	15	459	931	1552	2335	3476	6184	9156	11382	20298
	17	391	648	988	1748	2840	4698	6098	7628	9476
25	2,5 ÷ 12 (6÷12)*	685	1337	2191	3360	4971	8392	12870	15845	29200
	15	680	1320	2183	3356	4877	8284	12690	15710	29010
	17	641	1256	2084	3156	4670	7866	12370	14860	27720
28	5 ÷ 15 (6÷15)*	781	1521	3355	3864	5611	9862	14870	18380	33164
	17	763	1471	3259	3768	5506	9652	14340	17770	32665

For sizes from DN 15 to DN 50, please consult data sheet IS PRV47.10.

\* Minimum outlet pressures for the sizes DN 65 to DN 100.

ORDERING CODES PRV47											
<b>Valve model</b>	V47				S.	1			1.	A	15
PRV47 – standard steam use	V47										
PRV47G – compressed air and gases	V47G										
<b>Construction material</b>											
Standard steel construction	(1)										
Stainless steel construction	I										
<b>Remote control and pilots</b>											
Standard valve for external balance connection	(1)										
Valve with balance pipe connected to body	O										
Solenoid valve 220V for remote closure up to 10 bar – 180° for external balance connection	E										
Solenoid valve 220V for remote closure up to 10 bar – 180° with balance pipe on valve	EO										
Pressure sustaining / reducing for external balance connection <b>a)</b>	S										
Pressure sustaining / reducing with balance pipe on valve <b>a)</b>	SO										
Pressure sustaining / reducing / solenoid for external balance connection	Y										
Pressure sustaining / reducing / solenoid with balance pipe on valve	YO										
<b>Diaphragm type</b>											
Standard diaphragm	S.										
Low pressure diaphragm	L.										
<b>Outlet pressure</b>											
Green spring 0,35 to 2 bar – single diaphragm						1					
Blue spring 1,5 to 5,5 bar – single diaphragm						2					
Red spring 3,5 to 8,5 bar – double diaphragm						3					
Black spring 7 to 17 bar – double diaphragm						4					
Pneumatic control top 0,35 to 4 bar – single diaphragm						6					
Pneumatic control top 2 to 17 bar – double diaphragm						7					
<b>Piston rings</b>											
Bronze <b>c)</b>						(1)					
FKM <b>c)</b>						V					
EPDM <b>c)</b>						E					
NBR <b>c)</b>						N					
<b>Drain connection</b>											
Standard valve						(1)					
Drain connection 3/8"						D					
<b>Valve plug</b>											
Standard metal to metal with hardened plug									1.		
Stellited valve and plug									2.		
Soft plug – Virgin PTFE									3.		
Soft plug – PTFE/GR									4.		
Soft plug – Rulon									5.		
Soft plug – Viton									6.		
<b>Connections</b>											
Flanged EN 1092-1 PN16										L	
Flanged EN 1092-1 PN40										N	
<b>Size</b>											
DN 65											65
DN 80											80
DN 100											100
<b>Special valves / Extras</b>											
Full description or additional codes have to be added in case of non-standard combination.											E

(1) Omitted if a standard valve is requested.

**a)** PS7 sustaining valve, see catalog for spring range.

**c)** Valve limited to maximum operating temperature materials.