

PILOT OPERATED PRESSURE REDUCING VALVES PRV47 (Steel) and PRV47I (St. Steel)

DESCRIPTION

The ADCA PRV47 pilot operated pressure reducing valves are designed for use with steam, compressed air, nitrogen and other gases compatible with the construction materials. The PRV47 can be installed in pressure reducing stations throughout all industries, and provides sensitive and accurate control even when inlet pressure fluctuations or flow variations occur.

MAIN FEATURES

Robust complete steel or stainless steel construction.
Suitable for dead end conditions.
Guided piston and valve stem.
Hardened plug.

OPTIONS: Soft sealing.
 Low pressure top.
 Bottom cover drain connection.
 Stellited plug and seat.
 Internal balance orifice.

USE: Saturated steam, compressed air and other gases (Group 2) compatible with the construction (except oxygen).

AVAILABLE MODELS: PRV47 – standard model for steam.
 PRV47G – compressed air and gases.

VALVE SIZES: DN 15 to DN 50.

CONNECTIONS: Flanged EN1092-1 or ANSI.
 Threaded BSP, NPT or SW.

INSTALLATION: Horizontal installation.
 An “Y” strainer, a humidity separator and a steam trap should be installed upstream of the valve.
 See IMI – Installation and maintenance instructions.

ORDER REQUIREMENTS: Type of fluid.
 Maximum operating temperature.
 Inlet and outlet pressures.
 Flow rate (maximum and minimum).

BODY LIMITING CONDITIONS		
FLANGED PN40 / ANSI 300 lb *	FLANGED ANSI 150 lb **	RELATED TEMP.
ALLOW. PRESS.	ALLOW. PRESS.	
40 bar	19,3 bar	50 °C
37 bar	17,7 bar	100 °C
31 bar	12,5 bar	239 °C
28 bar	10,2 bar	300 °C

Minimum working temperature: -10 °C.

* Rating according to EN1092-1:2018.

** Rating according to EN1759-1:2004.



USEFUL NOTES ON VALVE AND PIPE SIZING

A special low top assembly should be fitted for outlet pressures ranging between 0,07 and 0,5 bar (Fig.2). Two regulators in parallel should be used on larger systems where minimum flow is less than 10% of the maximum. If the flow is unknown it is possible to estimate it, based on pipe sizing or equipment heat requirements – please consult factory.

The balance pipe is recommended to be connected in the downstream pipe at a minimum of 1 meter away from the valve. A spool piece can be supplied to house the balancing pipe.

HOW TO SELECT: Never size the valve according to the pipe diameter in which it has to be fitted, but according to the required actual flow of fluid. Refer to valve calculation table or consult factory.

LIMITING CONDITIONS	
Valve model	PRV47
Body design conditions	PN40
Max. upstream pressure (steam)	28 bar
Max. upstream pressure (air)	31 bar
Max. downstream pressure	17 bar
Min. downstream pressure *	0,35 bar
Max. operating temperature	250 °C
Max. reducing ratio	See capacity table
Rangeability	10:1
Max. cold hydraulic test	17 bar
Max. hydraul. factory valve body test	60 bar

* 0,07 bar w/ low press. top (limited to 7 bar inlet).

Press. and temp. may change if soft sealing or soft piston rings are used.

CE MARKING – GROUP 2 (PED – European Directive)	
PN40	Category
DN 15 to DN 32	SEP
DN 40 to DN 50	1 (CE Marked)

MATERIALS – PRV47 Steel construction

POS.	DESIGNATION	MATERIAL
1	Valve body	S355J2G3 / 1.0570 ; P250GH / 1.0460
2	Pilot valve body	CF8 / 1.4308
2A	Pilot valve body	CF8 / 1.4308
3	Top cover	CF8 / 1.4308
3A	Cover spring	CF8 / 1.4308
3B	Top cover	C45E / 1.1191
3C	Cover nut	C45E / 1.1191
4	* Main valve seat	AISI 316 / 1.4401
5	* Main valve	Hardened st. steel
5A	* Main valve (soft)	SS316 w/ PTFE/GR; Rulon
6	* Main valve spring	AISI 302 / 1.4300
7	* Piston	Bronze B62 / ASTM B148.97
8	* Piston Rings	Bronze / FKM / EPDM / NBR
9	Piston liner	AISI 304L / 1.4306
10	Bottom cover	S355J2G3 / 1.0570
11	* Bottom cover gasket	Stainless steel / Graphite
12	* Diaphragm	AISI 301 / 1.4310
12A	* Low press. diaphragm	AISI 301 / 1.4310
13	* Diaphragm gasket	Stainless steel / Graphite
13A	* Diaphragm gasket	Stainless steel / Graphite
14	* Pilot valve gasket	Stainless steel / Graphite
15	Lower spring carrier	Brass
16	* Adjustment spring	Steel
16A	Diaphragm spring	Stainless steel
17	Top spring carrier	Brass
18	Spring ID plate	Aluminium
19	* Pilot valve	AISI 316 / 1.4401
19A	* Pilot valve (soft)	PTFE/GR; Rulon, etc.
20	* Pilot valve seat	AISI 316 / 1.4401
20A	Pushrod	AISI 316 / 1.4401
21	* Pilot valve gasket	Copper
22	* Pilot valve spring	AISI 302 / 1.4300
23	Handwheel	Plastic / Stainless steel
23A	Locknut	AISI 304 / 1.4301
24	Bolts	Steel 10.9
24C	Bolts	Steel 10.9
24D	Studs	34CrNiMo / 1.6582
24E	Nuts	Steel 8.8
25	Compression fitting	Plated carbon steel
25A	Adapter	AISI 304 / 1.4301
25B	Plug	AISI 304 / 1.4301
25C	Gasket	Copper
26	Balance pipe	Copper
27	* Pilot valve strainer	AISI 304 / 1.4301
28	Strainer nut	AISI 304 / 1.4301
29	Gasket	Copper
100	** Press. regulator (relieving)	ADCA P10
102	** Steam trap	ADCA TH21
103	** Globe valve	ADCA GV32B
104	** Drain connect. nipple	Steel 1/2" x 3/8"
105	** Solenoid valve	Brass
106	** Sustaining valve	ADCA PS7
107	** Strainer	ADCA IS100I – Stainless steel

* Available spare parts; ** See pages 5 and 6.

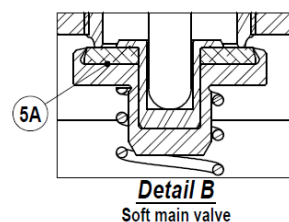
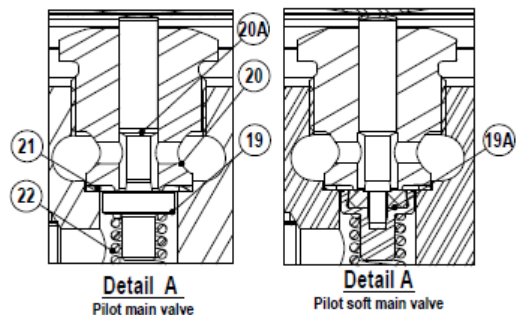
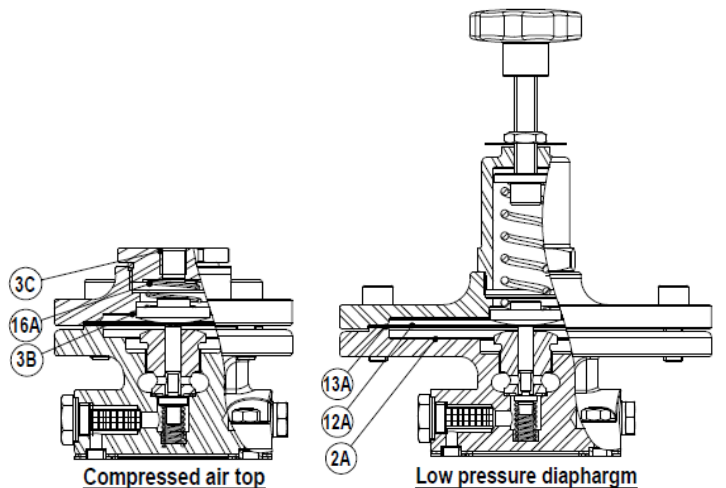
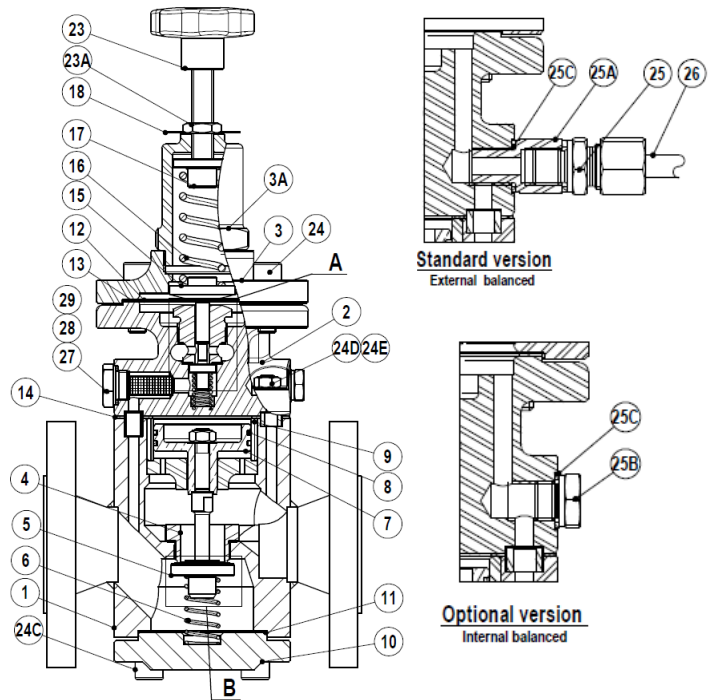

MATERIALS – PRV47I Stainless steel construction

POS. Nº	DESIGNATION	MATERIAL
1	Valve body	AISI 316 / 1.4401
2	Pilot valve body	CF8 / 1.4308
2A	Pilot valve body	CF8 / 1.4308
3	Top cover	CF8 / 1.4308
3A	Cover spring	CF8 / 1.4308
3B	Top cover	AISI 316 / 1.4401
3C	Cover nut	AISI 316 / 1.4401
4	* Main valve seat	AISI 316 / 1.4401
5	* Main valve	Hardened st. steel
5A	* Main valve (soft)	SS317 w/ PTFE/GR; Rulon
6	* Main valve spring	AISI 302 / 1.4300
7	* Piston	Stainless steel
8	* Piston Rings	Bronze / FKM / EPDM / NBR
9	Piston liner	AISI 304L / 1.4306
10	Bottom cover	AISI 316 / 1.4401
11	* Bottom cover gasket	Stainless steel / Graphite / PTFE
12	* Diaphragm	AISI 301 / 1.4310
12A	* Low press. diaphragm	AISI 301 / 1.4310
13	* Diaphragm gasket	Stainless steel / Graphite
13A	* Diaphragm gasket	Stainless steel / Graphite
14	* Pilot valve gasket	Stainless steel / Graphite
15	Lower spring carrier	Brass / Stainless steel
16	* Adjustment spring	Steel / Stainless steel
16A	Diaphragm spring	Stainless steel
17	Top spring carrier	Brass
18	Spring ID plate	Aluminium / Stainless steel
19	* Pilot valve	AISI 316 / 1.4401
19A	* Pilot valve (soft)	PTFE/GR; Rulon, etc.
20	* Pilot valve seat	AISI 316 / 1.4401
20A	Pushrod	AISI 316 / 1.4401
21	* Pilot valve gasket	Copper / PTFE
22	* Pilot valve spring	AISI 302 / 1.4300
23	Handwheel	Plastic / Stainless steel
23A	Locknut	AISI 304 / 1.4301
24	Bolts	Stainless steel A-4
24C	Bolts	Stainless steel A-4
24D	Studs	34CrNiMo / 1.6582
24E	Nuts	Steel 8.8
25	Compression fitting	Stainless steel
25A	Adapter	AISI 304 / 1.4301
25B	Plug	AISI 304 / 1.4301
25C	Gasket	Copper
26	Balance pipe	Stainless steel
27	* Pilot valve strainer	AISI 304 / 1.4301
28	Strainer nut	AISI 304 / 1.4301
29	Gasket	Copper / PTFE
100	** Press. regulator (relieving)	ADCA P10
102	** Steam trap	ADCA TH21
103	** Globe valve	ADCA GV32B
104	** Drain connect. nipple	Stainless steel 1/2" x 3/8"
105	Solenoid valve	Stainless steel
106	Sustaining valve	ADCA PS7
107	Strainer	ADCA IS100I – Stainless steel

* Available spare parts.; ** See pages 5 and 6.

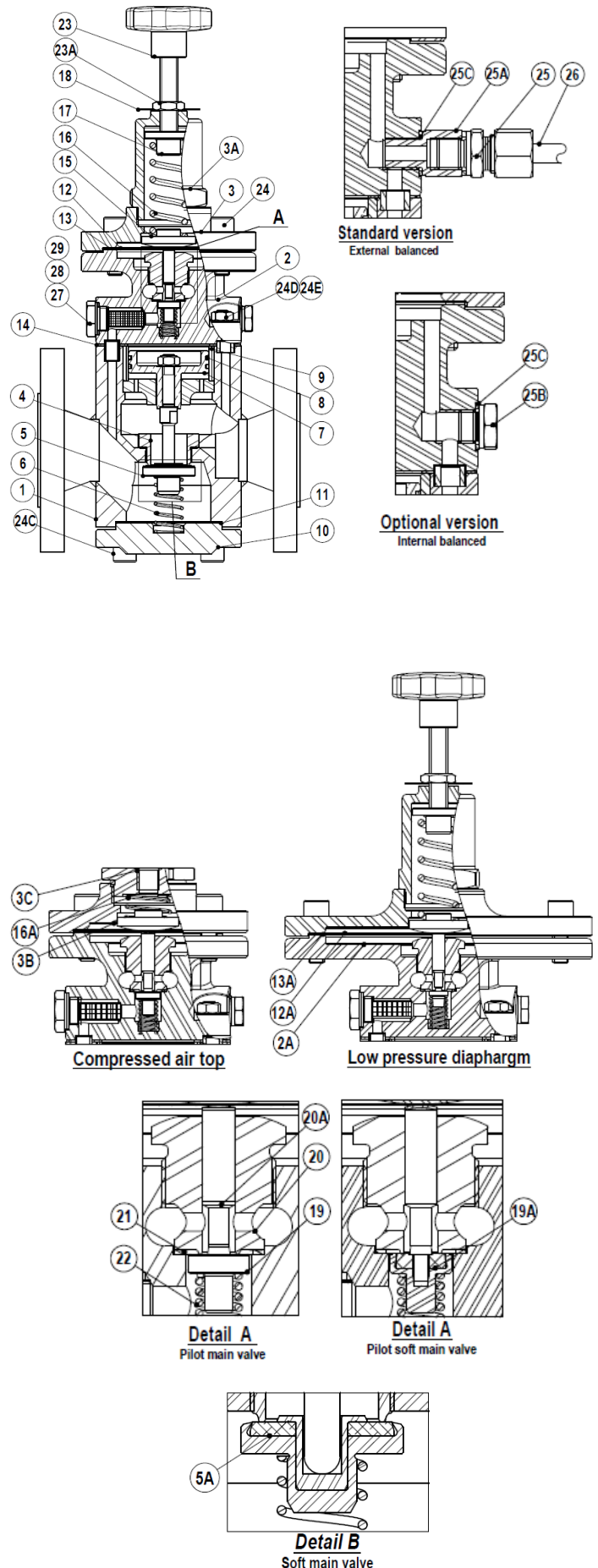

PRESSURE RANGES (bar)				
SPRING COLOUR	GREEN w/ 1 diaphragm	BLUE w/ 1 diaphragm	RED w/ 2 diaphragms	BLACK w/ 2 diaphragms
Red. Pressure	0,07 to 0,5 bar *	1,5 to 5,5 bar **	3,5 to 8,5 bar **	7 to 17 bar **
Red. Pressure	0,35 to 2 bar **	–	–	–

*With low pressure top; **Standard diaphragm.

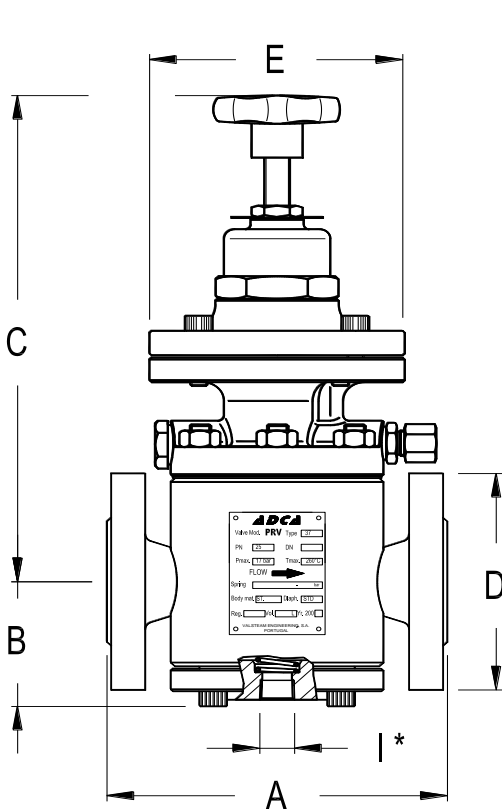

Fig.1

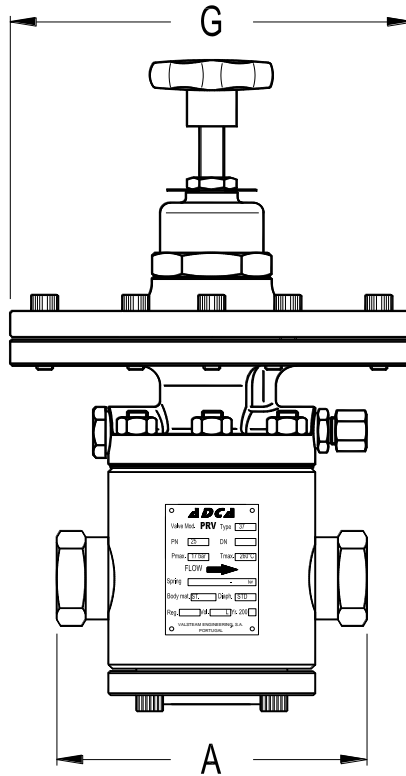

Fig.2

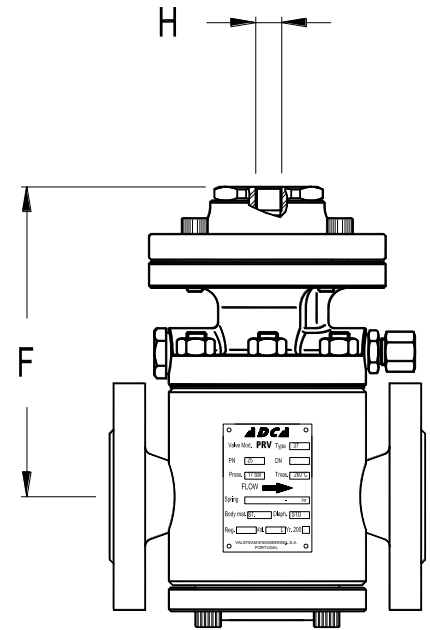

Fig.3

Fig. 1 - Valve with standard diaphragm; Fig. 2 - Valve with low pressure top; Fig. 3 - Valve with compressed air top.

* Drain connection (option) for steam trapping. This drain connection does not replace the humidity separator, but can be useful if, for example, the valve stops operating for large periods of time.

DIMENSIONS (mm)													
SIZE DN	A PN40 Flanges	A ANSI 150 lb Flanges	A ANSI 300 lb Flanges	A Threaded	B	C	D	E	F	G	H	I	WEIGHT (kg) *
15	150	184	190	140	56	275	95	120	162	195	1/4"	3/8"	13
20	150	184	194	140	56	287	105	120	174	195	1/4"	3/8"	13,5
25	160	184	197	150	56	287	115	120	174	195	1/4"	3/8"	14
32	180	-	-	170	68	299	140	120	186	195	1/4"	3/8"	18
40	200	222	235	190	75	307	150	130	194	195	1/4"	3/8"	22
50	230	254	267	230	84	323	165	160	210	195	1/4"	3/8"	31

* Approximated values, consult factory for certified weights.

EXAMPLE VERSIONS

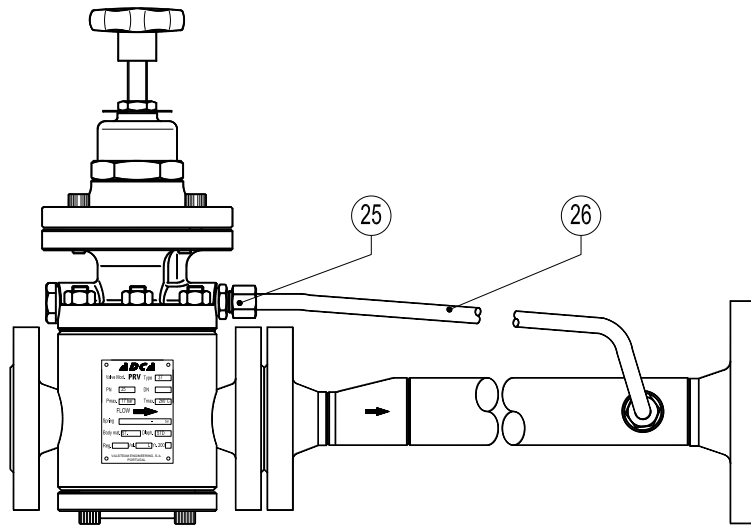

Fig.4

PRV47 standard, for steam, compressed air or gases (Fig.4)

The high pressure upstream fluid enters the main valve and the pilot valve. By compressing the regulating spring over the diaphragm, the pilot valve opens, admitting regulated pressure to the piston chamber. The force exerted by the regulated pressure on top of the piston pushes it down, which in turn opens the main valve. The downstream pressure is then transmitted through the balance pipe, acting below the diaphragm.

Any downstream pressure increase deflects the diaphragm, and the pilot valve closes, thus shutting off regulated gas to the piston which in turn closes the main valve. When the correct downstream pressure is achieved, the valve opens again, repeating the process.

Important: the balance pipe (n° 26) must always be connected, unless the valve was supplied with the balance connection inside the valve body. However, the fitting of the balance pipe is still highly recommended when:

- The reduced pressure is below 55% of the inlet pressure (mandatory for pressure reductions greater than 10:1);
- Instability of reduced pressure occurs;
- When a low pressure top assembly is fitted.
- When difficult outlet pipe work conditions occur.

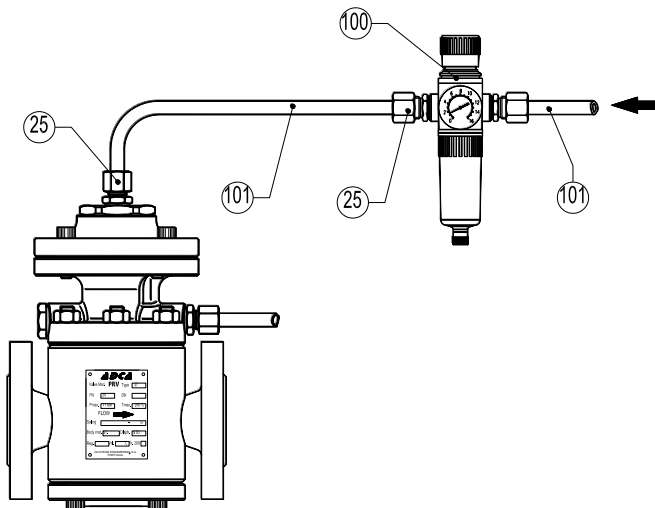

Fig.5

PRV47 valve with compressed air top (air loaded pilot) (Fig.5)

The loading force is exerted on the pilot valve diaphragm by an external compressed air signal rather than by the regulating spring.

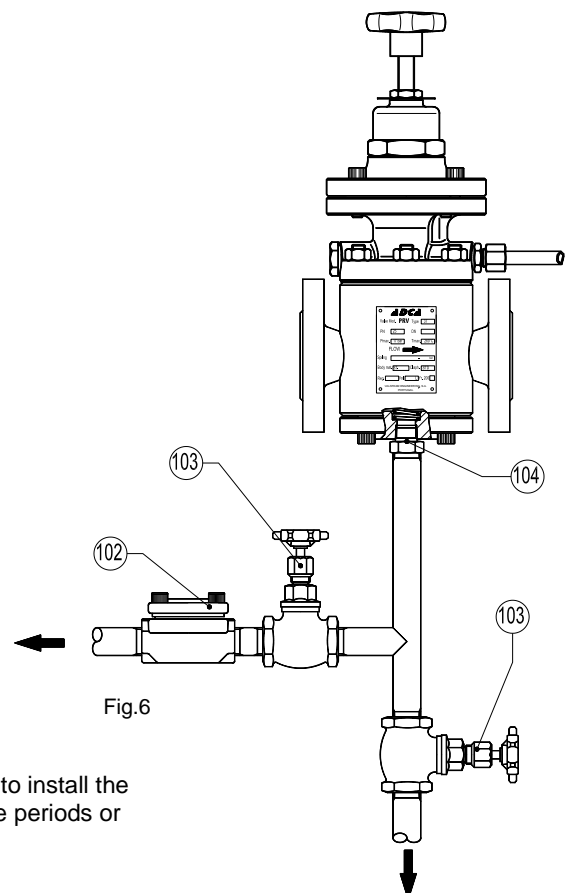

Fig.6

PRV47 with drain connection (Fig.6)

The optional drain connection is specially recommended when it isn't possible to install the humidity separator close to the valve, when the valve is on no-flow during large periods or for system cleaning during start up.

PRV47E with solenoid valve for electric remote control (Fig.7)

This valve version operates like the standard valve but it allows a remote closing, by means of a switch or timer. When the solenoid valve closes, the pressure signal to the pilot valve is interrupted and thus the main valve also closes.

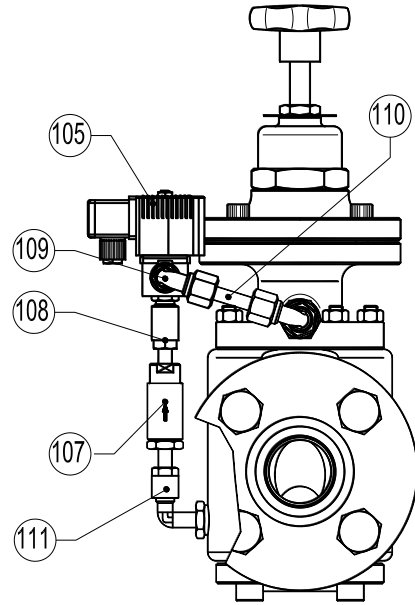

Fig.7

PRS47 pressure reducing and sustaining valve (Fig.8)

The PRS47 is a derivative of the PRV47 and consists in a combination between a pressure reducing valve and a pressure sustaining valve. While the pilot fitted on the main valve body controls downstream pressure, a secondary pilot valve (106), in this case a pressure sustaining valve, fitted on the side of the PRV controls the upstream pressure. The pressure sustaining valve is closed until the established set pressure is reached and so is the main valve, since there is no flow feeding its pilot. As soon as the set pressure is reached, the pressure sustaining valve opens allowing flow to the PRV's pilot valve, which in turn opens the main valve.

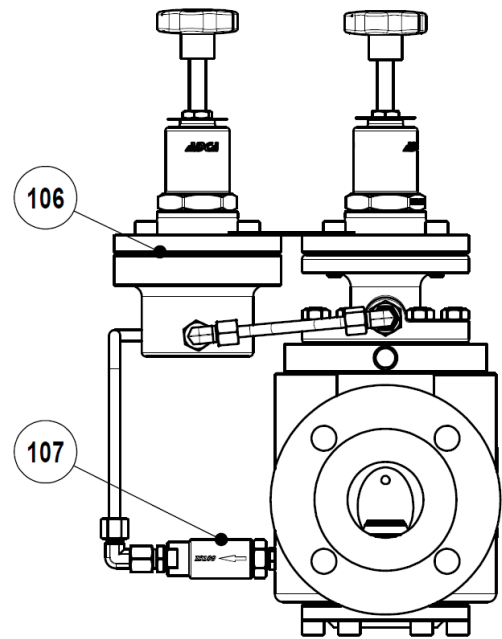

Fig.8

PRV47 – Steam capacity table (kg/h)							
INLET (barg)	OUTLET (barg)	SATURATED STEAM					
		DN 15	DN 20	DN 25	DN 32	DN 40	DN 50
0,7	0,35	40	75	125	190	280	480
1	0,4	45	95	160	240	355	620
	0,6	40	83	140	210	308	535
2	0,4 ÷ 1	75	150	250	380	545	960
	1,2	65	138	230	345	515	900
	1,6	50	105	175	265	393	685
3	0,4 ÷ 1,5	100	200	335	510	750	1310
	2	85	170	290	450	660	1155
	2,2	80	165	277	416	613	1050
	2,6	60	127	203	315	467	818
4	0,4 ÷ 2	125	250	420	630	920	1580
	2,5	114	225	385	580	850	1465
	3,2	92	183	309	482	708	1205
	3,6	68	137	237	353	536	932
5	0,4 ÷ 2	150	310	512	755	1114	1895
	3	144	295	488	743	1095	1835
	4	115	225	373	578	846	1430
	4,2	105	213	343	525	770	1342
6	0,4 ÷ 3	175	355	602	919	1358	2298
	4	159	314	538	827	1217	2142
	5	119	250	411	637	941	1644
	5,2	109	217	360	568	839	1465
7	0,4 ÷ 3,5	197	410	670	1005	1540	2644
	5	178	358	587	908	1345	2306
	6	132	271	452	688	1027	1773
	6,2	122	251	416	635	934	1618
8	0,4 ÷ 4	225	471	778	1169	1759	3043
	5	221	339	730	1118	1659	2884
	6	192	385	639	976	1451	2513
	7	146	293	481	732	1085	1887
9	7,2	137	274	453	692	1011	1782
	0,4 ÷ 5	251	518	856	1325	1923	3358
	6	241	500	788	1222	1766	3095
	7	206	398	679	1068	1559	2676
	8	156	314	514	794	1142	2053
10	8,2	145	292	483	741	1090	1888
	0,4 ÷ 5	275	561	944	1468	2127	3718
	6	272	551	917	1419	2074	3619
	7	252	508	838	1268	1871	3249
	8	213	431	722	1118	1659	2831
	9	163	333	548	843	1244	2152
12	9,2	150	298	493	756	1143	1929
	1 ÷ 6	330	680	1124	1732	2541	4407
	8	311	629	1023	1575	2332	4034
	10	265	533	812	1271	1867	3202
15	11	175	364	568	924	1350	2359
	1 ÷ 8	408	839	1373	2138	3118	5403
	12	339	656	1068	1629	2441	4250
17	14	199	401	662	1017	1503	2619
	1 ÷ 9	425	863	1460	2178	3165	5343
	15	347	709	1190	1816	2694	4712
20	16	207	416	717	1217	1608	2824
	1 ÷ 12	541	4062	1774	2746	4001	6971
	15	459	931	1552	2335	3476	6184
25	17	391	648	988	1748	2840	4698
	2,5 ÷ 12	685	1337	2191	3360	4971	8392
	15	680	1320	2183	3356	4877	8284
28	17	641	1256	2084	3156	4670	7866
	5 ÷ 15	781	1521	3355	3864	5611	9862
	17	763	1471	3259	3768	5506	9652

PRV47 – Comp. air capacity table (Nm ³ /h – 0 °C – 1,013 bar)							
INLET (barg)	OUTLET (barg)	SATURATED STEAM					
		DN 15	DN 20	DN 25	DN 32	DN 40	DN 50
0,7	0,35	15	31	50	70	111	191
1	0,4	16	33	51	79	113	194
	0,6	27	55	90	138	199	343
2	0,4 ÷ 1	60	122	201	307	444	763
	1,2	54	109	180	276	399	686
	1,6	45	91	150	230	333	572
3	0,4 ÷ 1,5	120	240	300	460	666	1150
	2	105	210	251	384	555	1050
	2,2	48	93	152	232	334	570
	2,6	45	61	101	154	223	384
4	0,4 ÷ 2	150	238	499	739	1089	1825
	2,5	135	208	449	568	978	1635
	3,2	119	177	398	492	867	1444
	3,6	60	124	202	154	444	763
5	0,4 ÷ 2	180	360	505	768	1110	1908
	3	165	330	556	691	997	1716
	4	151	298	404	613	885	1526
	4,2	136	285	383	582	840	1449
6	0,4 ÷ 3	210	468	696	1046	1523	2580
	4	195	437	646	969	1412	2389
	5	150	345	494	738	1079	1817
	5,2	135	315	443	664	968	1627
7	0,4 ÷ 3,5	240	480	804	1200	1740	2989
	5	210	421	701	1046	1524	2640
	6	150	301	499	756	1104	1829
	6,2	105	211	349	529	773	1280
8	0,4 ÷ 4	270	546	798	1353	1746	3411
	5	265	516	747	1276	1635	3220
	6	225	449	710	1125	1635	2762
	7	180	361	600	892	1296	2184
9	7,2	156	312	540	768	1128	1978
	0,4 ÷ 5	301	612	1011	1507	2244	3789
	6	270	553	910	1359	1980	3474
	7	240	492	816	1230	1798	2970
	8	180	360	598	903	1288	2247
10	8,2	165	329	547	826	1176	2056
	0,4 ÷ 5	330	659	1116	1692	2412	4173
	6	314	628	1065	1615	2301	3983
	7	288	599	1004	1503	2202	3810
	8	240	492	806	1212	1770	3022
	9	192	360	658	898	1350	2280
12	9,2	181	342	628	852	1283	2165
	1 ÷ 6	390	792	1300	1978	2844	4917
	8	360	732	1219	1827	2622	4497
	10	270	553	910	1359	1980	3474
15	11	210	468	696	1046	1523	2580
	1 ÷ 8	480	972	1602	2427	3564	6072
	12	375	762	1272	1923	2784	4692
17	14	255	528	889	1332	1896	3398
	1 ÷ 9	540	912	1819	2737	3984	6618
	15	315	708	1179	1764	2520	4418
20	16	255	528	889	1332	1896	3398
	1 ÷ 12	615	1254	2379	3153	4578	7911
	15	534	900	1799	2707	3940	6738
25	17	450	901	1497	2246	3336	5796
	2,5 ÷ 12	780	1590	2689	3982	5790	9902
	15	756	1530	2548	3828	5616	9600
28	17	720	1464	2412	3707	5130	9123
	5 ÷ 15	870	1770	2910	4430	6390	10950
	17	840	1724	2820	4320	6180	10680

ORDERING CODES PRV47											
Valve model	VR.47				S.	1			1.	A	15
PRV47 – standard steam use	VR.47										
PRV47G – compressed air and gases	VR.47G										
Construction material											
Standard steel construction		(1)									
Stainless steel construction		I									
Remote control and pilots											
Standard valve for external balance connection		(1)									
Valve with internal balance orifice		O									
Solenoid valve 220V for remote closure up to 10 bar – 180° for external balance connection		E									
Solenoid valve 220V for remote closure up to 10 bar – 180° with internal balance orifice		EO									
Pressure sustaining / reducing for external balance connection a)		S									
Pressure sustaining / reducing with internal balance orifice a)		SO									
Pressure sustaining / reducing / solenoid for external balance connection		Y									
Pressure sustaining / reducing / solenoid with internal balance orifice		YO									
Diaphragm type											
Standard diaphragm					S.						
Low pressure diaphragm					L.						
Outlet pressure											
Green spring 0,35 to 2 bar – single diaphragm						1					
Blue spring 1,5 to 5,5 bar – single diaphragm						2					
Red spring 3,5 to 8,5 bar – double diaphragm						3					
Black spring 7 to 17 bar – double diaphragm						4					
Pneumatic control top 0,35 to 4 bar – single diaphragm						6					
Pneumatic control top 2 to 17 bar – double diaphragm						7					
Piston rings											
Bronze c)						(1)					
FKM c)						V					
EPDM c)						E					
NBR c)						N					
Drain connection											
Standard valve								(1)			
Drain connection 3/8"								D			
Valve plug											
Standard metal to metal with hardened plug									1.		
Stellited valve and plug									2.		
Soft plug – Virgin PTFE									3.		
Soft plug – PTFE/GR									4.		
Soft plug – Rulon									5.		
Soft plug – Viton									6.		
Connections											
Threaded BSP ISO 7/1 Rp										A	
Threaded NPT ANSI B1.20.1										C	
Flanged EN 1092-1 PN40										N	
Flanged ANSI B16.5 150 lb										U	
Flanged ANSI B16.5 300 lb										V	
Size											
DN 15 or 1/2"											15
DN 20 or 3/4"											20
...											
Special valves / Extras											
Full description or additional codes have to be added in case of non-standard combination.											E

(1) Omitted if a standard valve is requested.

a) PS7 sustaining valve, see catalog for spring range.

c) Valve limited to maximum operating temperature materials.