

PISTON SENSING PRESSURE SUSTAINING VALVE PS31SS 1/2" – 2"; DN 15 – DN 50

DESCRIPTION

The ADCA PS31 series direct acting, spring-loaded piston sensing, pressure sustaining valves are designed for use on compressed air, water, and other gases or liquids compatible with the materials of the construction. They are suitable for pressure sustaining applications where low capacity is required. This valve main purpose is to maintain the upstream pressure under control. Connections are female screwed or flanged.

MAIN FEATURES

Compact design.
Machined from bar stock materials or investment casting.

OPTIONS: Different soft valves for water and gases.
Built-in strainer.
1/4" gauge connection on body.
Regulating screw with top cap.

USE: Compressed air, water and other gases and liquids compatible with the construction.

AVAILABLE MODELS: PS31SS – Stainless steel.

SIZES: 1/2" to 2".
DN 15 to DN 50.

CONNECTIONS: Female screwed ISO7/1Rp (BS 21) or NPT.
Flanged EN 1092-1 PN40 – PN63.
Special flanges upon request.

INSTALLATION: Horizontal installation.
An "Y" strainer should be installed upstream the valve.
See IMI – Installation and maintenance instructions.

ORDER REQUIREMENTS: Type of fluid.
Maximum operating temperature.
Required opening pressure capacity (maximum and minimum).



PS31SS 1/2" – DN 15

CAPACITIES						
Valve size (DN)	15	20	25	32	40	50
Kvs (m ³ /h)	3	3,5	7,5	8,2	14,4	15,4

LIMITING CONDITIONS	
Valve model	PS31SS
Body design conditions	PN63
Max. upstream pressure	50 bar
Min. upstream pressure	3 bar
Max. design temperature *	80 °C

* Others on request.

Warning: Sustaining valves are not a substitute for safety valves or vacuum relief valves.

CE MARKING – GROUP 2 (PED – European Directive)		
PN16	PN40 / PN63	Category
1/2" to 2" DN 15 to DN 50	1/2" to 1 1/4" DN 15 to DN 32	SEP
–	1 1/2" to 2" DN 40 to DN 50	1 (CE marked)

DIMENSIONS (mm) - SCREWED

SIZE	A	B	C	WGT. (kg)
1/2"	80	38	175	2,6
3/4"	80	38	175	2,6
1"	105	66	320	8,6
1 1/4"	125	66	320	9,7
1 1/2"	205	86	305	14,8
2"	201	80	305	15,1

Different face to face dimensions on request.

DIMENSIONS (mm) - FLANGED

SIZE DN	PN16 / PN40			PN63 / PN100			
	D *	E	WGT. (kg)	D *	E PN63	E PN100	WGT. (kg)
DN 15	150	47,5	4	210	52,5	52,5	4,9
DN 20	150	52,5	4,7	230	70	70	6,9
DN 25	160 (230)	57,5	10,7 (12,4)	230	70	70	15,1
DN 32	260	70	13,5	260	77,5	77,5	16,5
DN 40	200	75	18,1	260	85	85	22,1
DN 50	** 230	82,5	20,3	300	90	97,5	24,6

* Different lenghts and ANSI flanges available on request.

** Only available with flat flanges EN1092-1 type 01 A. Welding neck type 11 B flanges as option, with a minimum of 300 mm face to face dimensions.

() : Alternative.

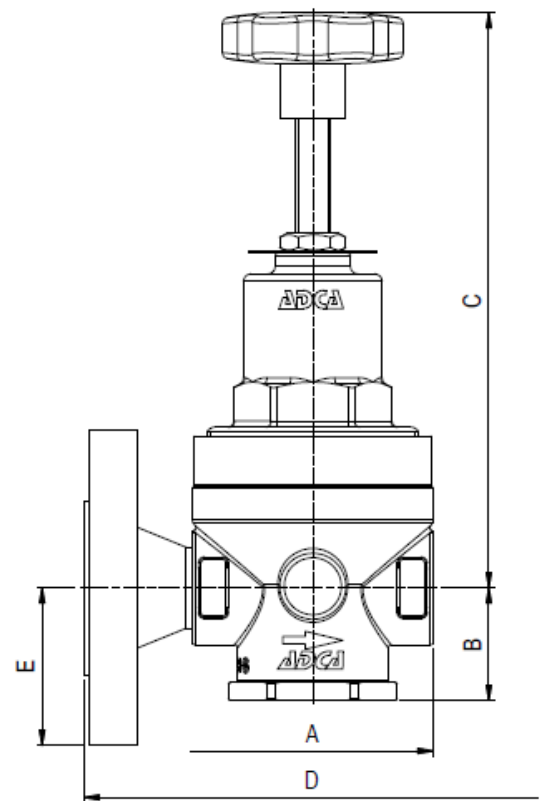

PS31SS 1/2" - DN 15

MATERIALS

POS. N°	DESIGNATION	MATERIAL
1	Valve body (a)	CF8M / 1.4408 (AISI 316 / 1.4401)
1A	Piston sleeve	AISI 316 / 1.4401
2	Top cover (b)	CF8M / 1.4408 (AISI 316 / 1.4401)
3	Seat cover (a)	CF8M / 1.4408 (AISI 316 / 1.4401)
4	* O-ring	NBR
5	Valve seat	AISI 316 / 1.4401
6	Sealing	NBR
7	* O-ring	NBR-EPDM-PTFE, etc.
9	Piston	AISI 316 / 1.4401
9A	* O-ring	NBR-EPDM-PTFE, etc.
11A	* O-ring	NBR-EPDM-PTFE, etc.
12	Gasket	Aluminium
13	Spring plate	AISI 304 / 1.4301
15	* Adjustment spring	Spring steel
16	Top spring plate	Brass
17	Adjustment screw	AISI 304 / 1.4301
18	Locknut	Stainless steel A2-70
19	Handwheel	Plastic
20	Spring Id. plate	Aluminium

* Available spare parts.

Remarks: All valves have a serial number. In case of non-standard valves this number must be supplied if spare parts are ordered.

a) Barstock execution on request (standard for sizes DN32-50).

b) Barstock execution on request.

