

## PNEUMATIC CONTROL VALVES PV928

(V928 hygienic angle valve with linear actuator PA series)

### DESCRIPTION

The PV928 are two or three way control valves with angle connections, specially designed for food, chemical, pharmaceutical and cosmetic industries among others. The PA pneumatic actuator features a rubber diaphragm and multi-springs. Its action can be DA - direct action (air to close) or RA-reverse action (air to open). The PV928 valves have been designed to ensure an accurate control in any process condition and they have self draining design.

### MAIN FEATURES

Quick disassembling through clamp body bonnet coupling.  
Completely made from solid bar stock material.  
Valve bonnet permanently attached to the body, removal is unnecessary for replacing the actuator.  
Metal to metal or soft sealing.  
Self draining design.

### STANDARD SURFACE FINISH

Internal wetted parts:  $\leq 0,51$  micron Ra – SF1.  
External:  $\leq 0,76$  micron Ra – SF3.  
Other surface conditions see IS PV20.00 E – Technical information.

Ultrasonic cleaning.

Actuator (stainless steel): Satin bead blast finish 1,6 micron Ra.

Actuator (steel): Electrostatic painted.

OPTIONS: Soft sealing.  
Steam barrier.  
Low noise and anti-cavitation plugs.  
Positioners and position transmitters.  
Air filter regulator.

USE: Saturated steam, hot and superheated water.  
Process fluids, liquids, air and gases compatible with the construction.

AVAILABLE MODELS: PV928L – Two way angle valve.  
PV928H – Two way horizontal valve.  
PV928M – Three way mixing valve.  
PV928D – Three way diverting valve.

VALVE SIZES: DN 15 to DN 100.  
CONNECTIONS: DIN, others on request.  
Tube weld, clamp ferrules and threads.

VALVE PORT: Full port as standard.  
Reduced or micro flow on request.

PLUG TYPES: Equal percentage (EQP).  
Linear (PL).

PACKAGING: Assembling and packaging in a clean room certified according to ISO 14644-1.  
The product is end capped and sealed with recyclable thermo-shrinkable plastic film, to avoid contamination.

HOW TO SELECT: Never size the valve according to the pipe diameter in which it has to be fitted, but according to the required actual flow of fluid. Refer to valve calculation table or consult factory.



PNEUMATIC ACTUATORS: PA205; PA280; PA340; PA435.  
ACTUATOR CONNECTIONS: 1/4" NPT-F.  
CONTROL SIGNAL: 0,4 – 1,2 bar; 0,4 – 2 bar.  
ELECTRIC ACT.: Consult IS EL 20.00 E.  
MAX. AIR SUPPLY: 3,5 bar.  
AMBIENT TEMPERATURE: - 20 °C to +70 °C.

LIMITING CONDITIONS	
Valve model	V928
Body design conditions	PN16
Maximum operating pressure	13 bar @ 38 °C
Maximum operating steam pressure	6 bar
Max. operating temp. (steam and water)	170 °C
Maximum operating temperature (air)	150 °C
Minimum operating temperature	- 10 °C

Higher and lower limits on request.

CE MARKING (PED – European Directive)	
PN16	Category
DN 15 to DN 50	SEP
DN 65 to DN 100	1 (CE Marked)

**FLOW RATE COEFFICIENTS (Kvs)**

SEAT Ø (mm)	VALVE STROKE (mm)	SIZES								
		DN 15	DN 20	DN 25	DN 32	DN 40	DN 50	DN 65	DN 80	DN 100
4 *	20	0,1	–	–	–	–	–	–	–	–
4 *		0,25	–	–	–	–	–	–	–	–
4 *		0,5	–	–	–	–	–	–	–	–
8 *		1	–	–	–	–	–	–	–	–
8 *		1,5	–	–	–	–	–	–	–	–
8 *		2	2,4	–	–	–	–	–	–	–
12		2,3	2,8	3	–	–	–	–	–	–
12		2,9	3,7	4	4,3	–	–	–	–	–
15		4,2	5,2	6,5	7,8	8,4	–	–	–	–
19		–	7	8,7	9,8	11,2	12,3	–	–	–
25		–	–	12	14,7	18	21,1	23	–	–
32		–	–	–	17,8	21	25,4	31	34	–
38		–	–	–	–	22,2	27,7	34,6	40,8	44,7
50		–	–	–	–	–	40,1	49	61	68
65	30	–	–	–	–	–	63,4	79,2	91	
76		–	–	–	–	–	–	89,7	112,1	
96		–	–	–	–	–	–	–	136,7	

\* Microflow available only with contoured linear characteristic.  
 For conversion  $Kvs = Cv (US) \times 0,855$ .

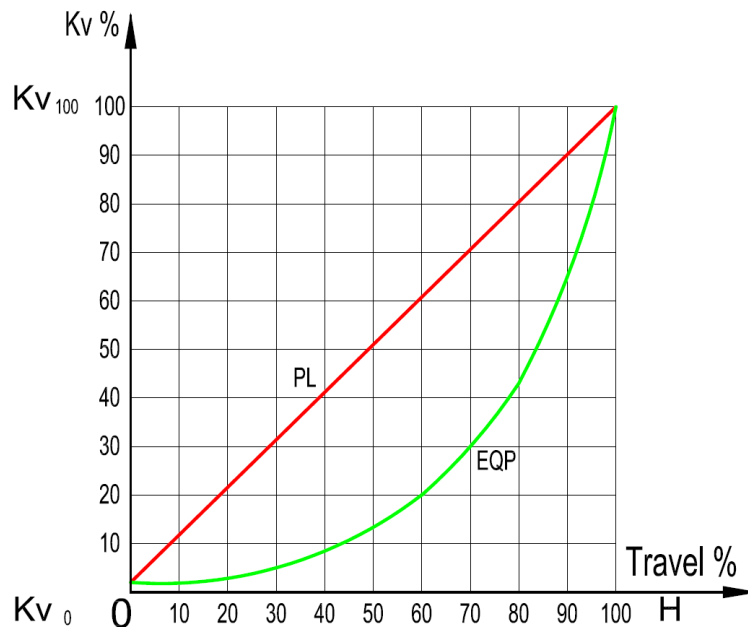

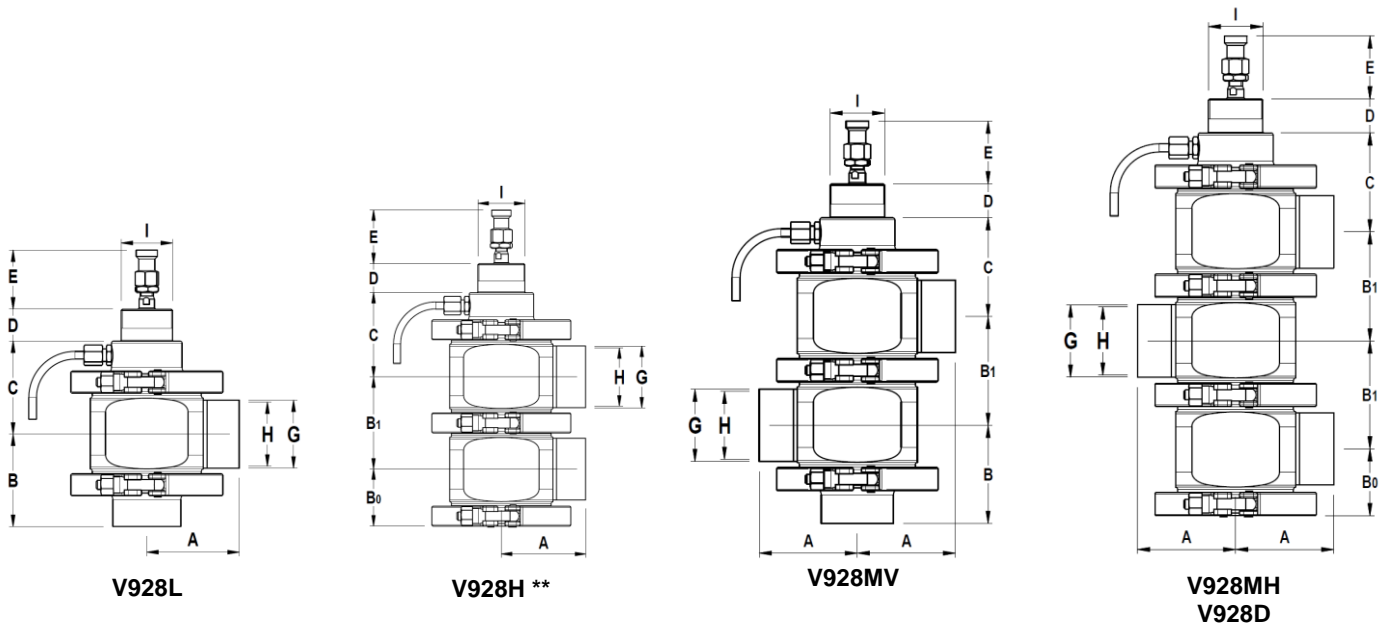

DIMENSIONS (mm) DIN															
SIZE DN	A(1)	B(1)	A(2)	B(2)	A(3)	B(3)	B0	B1	C	D	E	G	H	I	WGT. * (kg)
15	45	45	57	65	70	78	34	50	56	25	45	19	16	M40x1,5	2,1
20	45	45	57	65	72	80	34	50	56	25	45	23	20	M40x1,5	2,3
25	55	55	55	66	63	84	36	55	59	25	45	29	26	M40x1,5	2,7
32	56	56	69	71	88	91	40	62	63	25	45	35	32	M40x1,5	3,8
40	64	64	77	74	74	97	45	73	69	25	45	41	38	M40x1,5	3,9
50	72	72	83	80	82	107	51	85	75	25	45	53	50	M40x1,5	5,1
65	86	86	92	92	104	126	64	110	92	25	45	70	66	M45x1,5	9,9
80	109	109	92	106	109	154	71	125	100	25	45	85	81	M45x1,5	10,9
100	119	119	98	116	124	173	80	144	109	25	45	104	100	M45x1,5	16,2

Face to face dimensions are not standardized. Different dimensions available on request.

Key: A(1) – B(1) – Tube weld DIN 11866 Series A (DIN 11850).

A(2) – B(2) – Clamp ferrules DIN 32676 Series A.

A(3) – B(3) – Hygienic male threaded ferrule DIN 11851, for pipe DIN 11866 Series A (DIN 11850).

Alternative: Aseptic male threaded ferrule DIN 11864 Series 1 Form A, for pipe DIN 11866 Series A (DIN 11850).

Other dimensions and standards on request.

\* Weight is based on the standard valve V928L with tube weld connections. For other versions, consult factory.

\*\* Configuration with overlapped connections only possible for tube weld design.

DIMENSIONS PNEUMATIC ACTUATOR			
Type	D (mm)	Ø E (mm)	WEIGHT (kg)
PA205	235	210	5,7
PA280	240	275	8,8
PA340	265	335	14,3
PA435	295	430	24,5

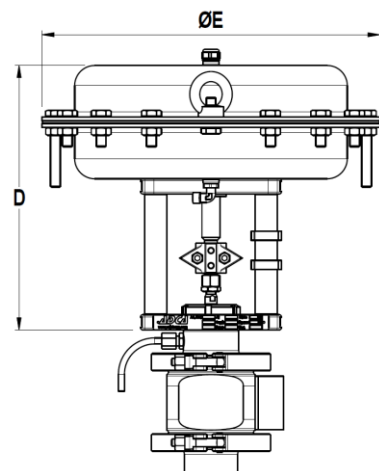

MATERIALS		
POS. Nº	DESIGNATION	MATERIAL
1	Valve body	AISI 316L / 1.4404
2	Bonnet	AISI 316L / 1.4404
2A	Bottom cover / connection	AISI 316L / 1.4404
3	* Valve plug	AISI 316L / 1.4404
4	Plug disc	AISI 316L / 1.4404
5	* Stem	AISI 316L / 1.4404
6	Valve plug seal	High performance EPDM
7	O-ring	High performance EPDM
8	Centering ring	AISI 316L / 1.4404
9	* O-ring	High performance EPDM
10	* Shaft seal	High performance EPDM
11	* Guide bushing	TFM 1600
12	* O-ring	EPDM
13	* Scraper ring	Viton
14	Clamp	AISI 316 / 1.4401
15	Leak-off connection	AISI 304 / 1.4301
15A	Nipple	AISI 316L / 1.4404
16	Discharge pipe	AISI 316 / 1.4401
17	Nut adapter	AISI 316 / 1.4401
18	Lock nut	Stainless Steel A2 – 70
19	Spring	AISI 302 / 1.4300
20	* Packing (chevron rings)	PTFE
21	* O-ring	High performance EPDM
22	* Washer	AISI 304 / 1.4301
23	Gland nut	AISI 316L / 1.4404
50	Yoke (steel)	C45E / 1.1191
	Yoke (stainless steel)	AISI 304 / 1.4301
51	Actuator (steel)	S235JRG2 / 1.0038
	Actuator (stainless steel)	AISI 304 / 1.4301
52	* Diaphragm	NBR 70
53	Lock nut	CF8 / 1.4308
54	Coupling (travel indicator)	CF8 / 1.4308

\* Available spare parts;  
 FDA / USP Class VI seals certificate on request.  
 All valves have a serial number. In case of non standard valves this number must be supplied if spare parts are ordered.

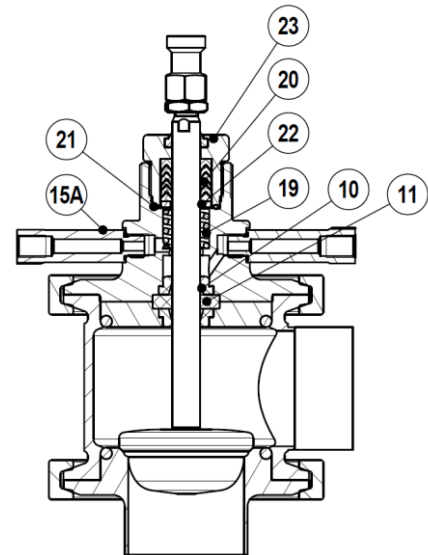
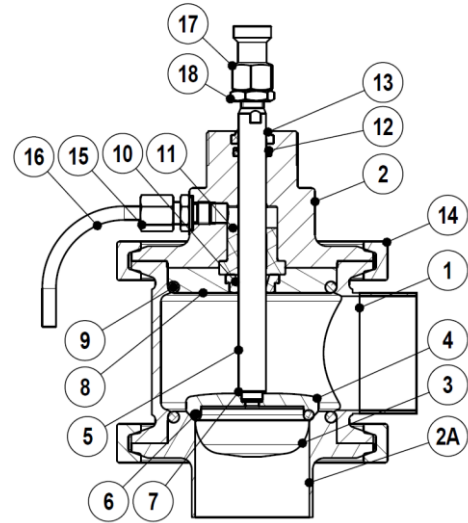

Valve with steam barrier option.

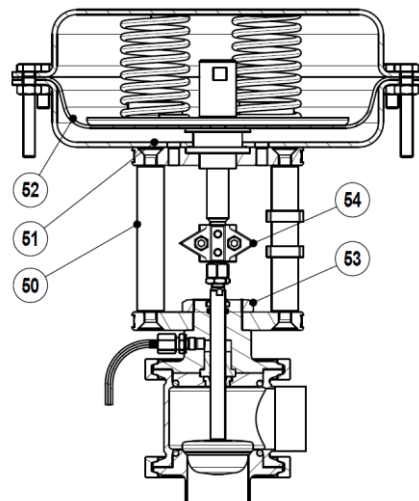

## HOUSINGS DESIGNS AND CONNECTIONS

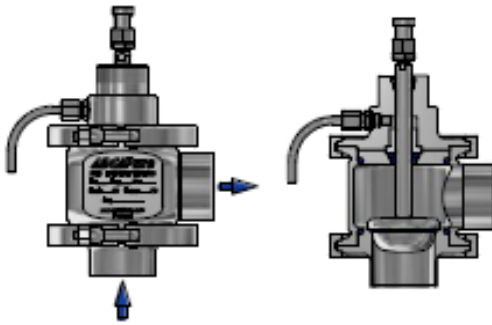

### V928 Type L

Two way basic hygienic standard design with one angle main valve body type connection.  
 The vertical valve inlet has the integrated valve seat.  
 The flow connection should always be against the plug closing direction.

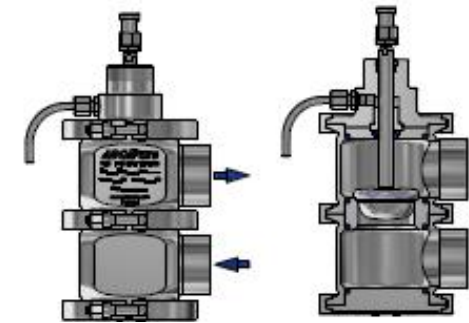

### V928 Type H

Two way design with two main valve bodies each one with an horizontal connection.  
 The valve seat is placed between the two main bodies.  
**Configuration with overlapped connections only possible for tube weld design.**

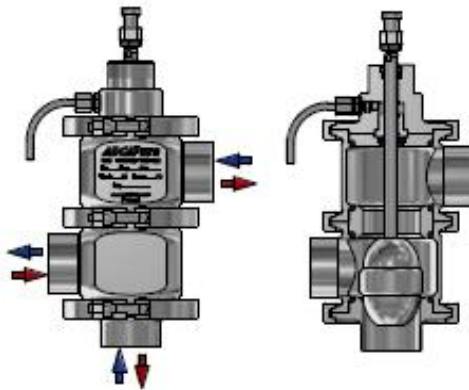

### V928 Type MV

Three way valve design with two main valve bodies and with a bottom vertical connection.  
 This valve can be used for mixing or diverting.

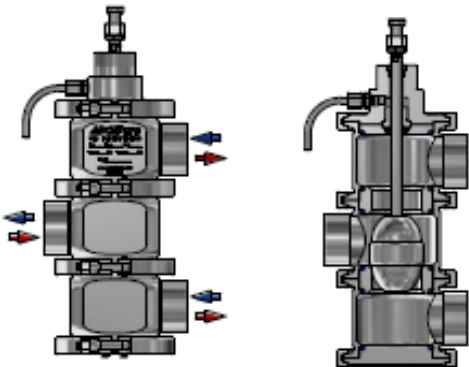

### V928 Type MH

Three way valve design with three main bodies and all the connections on the horizontal plan.  
 This valve can be used for mixing or diverting.

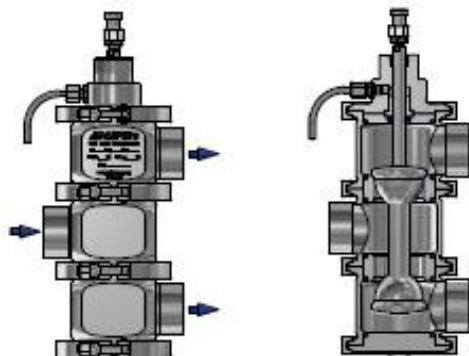

### V928 Type D

Three way valve design with three main bodies and connection in an horizontal plan.  
 This valve is designed for flow diverting.

ORDERING CODES V928							
VALVE CODES	P	V	.98L	1	F I	15	.X.
<b>Actuator type (1)</b>							
Pneumatic actuator	P						
Electric actuator	E						
<b>Group designation</b>							
Globe valve, two / three way		V					
<b>Valve model</b>							
V928L – Two way angle valve			.98L				
V928H – Two way horizontal valve			.98H				
V928MV – Three way angle mixing / diverting valve			.98MV				
V928MH – Three way horizontal mixing / diverting valve			.98MH				
V928D – Three way diverting valve			.98D				
<b>Valve plug</b>							
EQP (equal percentage) – Soft (High performance EPDM)				1			
EQP (equal percentage) – Metal (AISI 316L / 1.4404)				3			
PL (linear) – Soft (High performance EPDM)				6			
PL (linear) – Metal (AISI 316L / 1.4404)				7			
<b>Pipe connection</b>							
Tri-clamp ferrules DIN (DIN 32676-A)					F		
Hygienic male threads DIN (DIN 11851)					G1		
Aseptic male threads DIN (DIN 11864-1 Form A)					G2		
Tube weld DIN (DIN 11866-A)					F I		
<b>Size</b>							
DN15						15	
DN20						20	
DN25						25	
...							
<b>Actuator</b>							(1)
<b>Extras (3)</b>							E

ACTUATOR CODES (pneumatic)				
<b>Group designation</b>				
Multi-spring, pneumatic linear actuator	P.			
<b>Actuator size</b>				
205	1			
280	3			
340A – From DN 15 to DN 50	5			
340B – From DN 65 to DN 100	6			
435A – From DN 15 to DN 50	7			
435B – From DN 65 to DN 100	8			
<b>Actuator type</b>				
Direct action (air to close)	D			
Reverse action (air to open)	R			
<b>Actuator Construction</b>				
Steel construction (painted) – AdcaPure range	P			
Stainless steel construction – AdcaPure range	H			
<b>Control signal</b>				
0,4 – 1,2 bar (6-18 psi)				18
0,4 – 2 bar (6-30 psi)				30
0,4 – 2,4 bar (6-35 psi)				35

→ To be introduced on “.X.”, if supplied in combination with the valve.

Example:

PV928L two way angle valve DN 50, male threads DIN 11851, complete with reverse action actuator signal 0,4 – 2 bar, size 340A steel:

Code: PV.98L1G150.5RP30

REMARKS:

- (1) – Indicate actuator type.
- (3) – To be used only when a non-standard combination valve is supplied.

Adcapture control valves are identified by a serial number on a nameplate, located on the valve and/or actuator yoke.

When ordering spares, always use that serial number. If the valve has non-standard extras the serial number also has an E (extras).