

## FLASH VESSELS RV

### DESCRIPTION

The flash vessel is the main component in any flash recovery system. It can be used in all steam plants where high pressure condensate is reduced to a lower pressure, so that flash steam is formed by re-evaporation. This steam can be used in low pressure process or heating equipments.

Connections are flanged or screwed on request.

### MAIN FEATURES

Several possibilities of installation and special sizes and types (available on request).

**OPTIONS:** Complete stainless steel construction.  
Installation supports on body (without supporting feet).

**USE:** High pressure condensate.  
Boiler blowdown heat recovery systems.

**AVAILABLE MODELS:** RV...A/S; RV...L/S - carbon steel body.  
RV...A/SS; RV...L/SS - st. steel body.  
(A – angle; L – inline connections).

**SIZES:** RV06, RV08, RV12, RV16 and RV18.

**CONNECTIONS:** Flanged EN 1092-1 PN16.  
Special flanges upon request.

**INSTALLATION:** Vertical installation.  
Horizontal condensate inlet and outlet or alternative horizontal inlet and vertical condensate outlet.  
See AD (assembly drawing).



RV/A



CE MARKING – GROUP 2 (PED – European Directive)	
PN16	Category
RV06	2 (CE marked)
RV08	2 (CE marked)
RV12	3 (CE marked)
RV16	3 (CE marked)
RV18	3 (CE marked)

LIMITING CONDITIONS *											
RV/S						RV/SS					
PN16	Pressure (bar)	Temp. (°C)	ANSI Cl. 150 lb	Pressure (bar)	Temp. (°C)	PN16	Pressure (bar)	Temp. (°C)	ANSI Cl. 150 lb	Pressure (bar)	Temp. (°C)
	16	50		16	50		16	50		16	50
	14	100		14	100		16	100		16	100
	13 **	195		13 **	195		13 **	195		13 **	195
	12	250		–	–		12	250		–	–

Minimum operating temperature: -10 °C; Design code: AD-Merkblatt.

\* Rating according to EN 1092-1:2018; \*\* PMO - Maximum operating pressure for saturated steam.

APPROXIMATE DIMENSIONS (mm) \*

FLANGED EN1092-1

MODEL	A	A1	B	C	D	D1	E	F	G	H	I	I1	d1	d2	d3	d4	WGT. (kg)
RV06	1400	1200	185	170	800	600	635	50	50	50	853	-	3/4"	2"	1/2"	1"	36
RV08	1500	1300	210	220	810	610	645	80	80	50	908	-	1"	2"	1/2"	1"	56
RV12	1540	1340	265	325	830	630	660	100	100	50	908	-	1 1/2"	2"	1/2"	1"	92
RV16	1660	1460	310	410	930	730	725	150	150	80	-	480	1 1/2"	2"	1/2"	1 1/2"	146
RV18	1610	1410	330	460	965	765	755	150	150	80	-	485	2"	2"	1/2"	1 1/2"	174

\* For certified and ANSI dimensions, consult factory; Other sizes available on request.

Remarks: For the correct selection it is required the condensate flow rate and temperature when arriving to the flash vessel, as well as the flash steam pressure required.

Auxiliary equipment is recommended. Consult the factory for the correct flash vessel selection and system design, including all the necessary accessories.

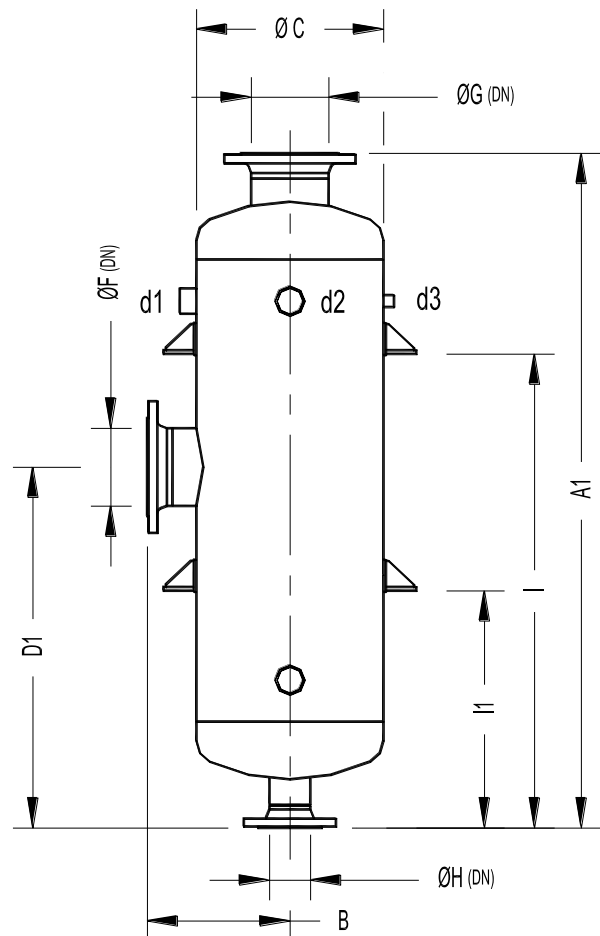
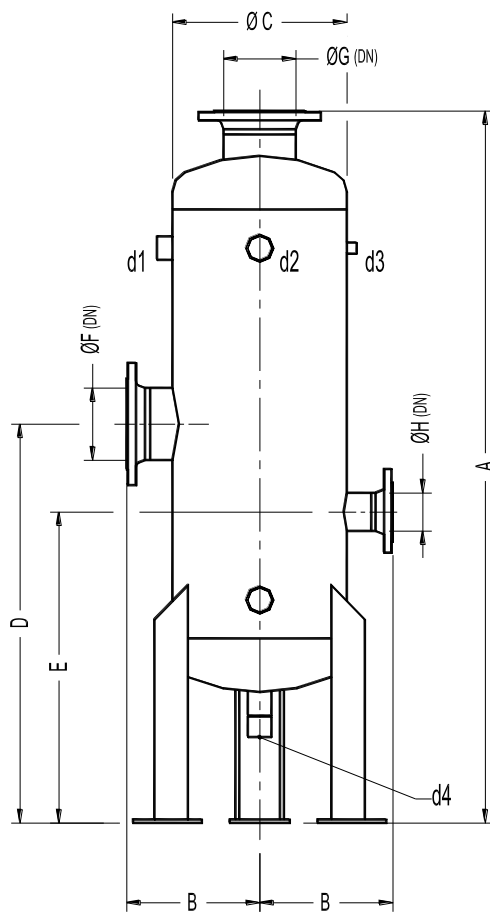

MATERIALS		
DESIGNATION	MATERIAL RV/S	MATERIAL RV/SS
Heads and shell	P265GH / 1.0425; P235GH / 1.0345	AISI 316 / 1.4401; AISI 316L / 1.4404
Inlet / outlet pipes	P235GH / 1.0345	AISI 316 / 1.4401
EN flanges	P250GH / 1.0460	AISI 316 / 1.4401
ANSI flanges	ASTM A105 / 1.0432	AISI 316 / 1.4401
Sockets	ASTM A105 / 1.0432	AISI 316 / 1.4401
Supports	S235JR / 1.0038	AISI 304 / 1.4301