

HUMIDITY SEPARATORS

Clean Steam Centrifugal Separator S11 (Inline connections)

DESCRIPTION

When wet steam is used in sterilization, moisture in suspension reduces the heat transfer efficiency, and the validity of the sterilization process can be compromised. S11 series centrifugal separators remove moisture from steam pipelines. Steam passes through the separator and, as a result of centrifugal forces, impact and swirling effects, the particles with a heavier specific gravity are separated, such as water droplets and moisture in suspension.

The condensate collected at the bottom of the separator must be automatically drained by a suitable steam trap.

MAIN FEATURES

- 316L stainless steel construction.
- No moving parts.
- Self draining design.

STANDARD SURFACE FINISH

- Internal wetted parts: $\leq 0,51$ micron Ra – SF1.
- External: Satin bead blast finish – 1,6 micron Ra.
- Other surface conditions see IS PV20.00 E - Technical information.

OPTIONS:

Vent connection.

USE:

Different kinds of connections and dimensions.

AVAILABLE MODELS:

Steam, compressed air and other gases (Group 2).

S11.

SIZES:

S11A – with air vent connection.

1/2", 3/4", 1", 1 1/2" and 2".

PIPE CONNECTIONS:

Clamped ends ASME BPE.

Other sanitary clamp or tube weld connections available on request.

PACKAGING:

Assembling and packaging in a clean room certified according to ISO 14644-1.

The product is end capped and sealed with recyclable thermo-shrinkable plastic film, to avoid contamination.

INSTALLATION:

Always with the condensate discharge pointing downwards. See IMI, installation and maintenance instructions.

HOW TO SELECT:

Generally, in an existing plant it is advisable to fit a separator with the same size of the pipe line. Pressure drop is normally negligible. For approximate pressure drop calculation please consult.



CE MARKING (PED – European Directive)	
PN10	Category
1/2" to 2"	SEP

LIMITING CONDITIONS		
Rating	Press. (bar)	Temp. (°C)
PN10	10	50
	8 *	175
	7,4	200

PMO – Max. operat. press. for saturated steam.
 Minimum operating temp.: -10 °C.
 Design code: AD-Merkblatt

APPROXIMATE DIMENSIONS (mm) ASME BPE

SIZE	A	B	C	D	E	F1	F2	F3	H1	H2	H3	VOL. (dm ³)	WGT. (kg)
1/2"	215	114	345	283,5	62,5	25	25	50,5	9,4	9,4	22,1	2,43	2,61
3/4"	215	114	345	283,5	62,5	25	25	50,5	15,75	9,4	22,1	2,44	2,61
1"	215	114	345	283,5	62,5	50,5	25	50,5	22,1	9,4	22,1	2,45	2,73
1 1/2"	235	141	416	338,5	77,5	50,5	25	50,5	34,8	9,4	22,1	4,48	5,64
2"	260	141	416	338,5	77,5	64	25	50,5	47,5	9,4	22,1	5,54	5,76

Consult factory for certified dimensions. Dimensions subject to change without notice.

* Vent connection as optional.

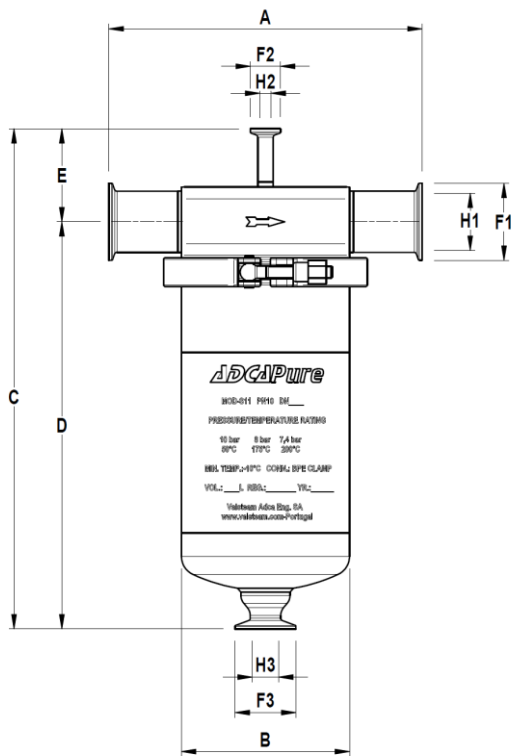

MATERIALS		
POS. Nº	DESIGNATION	MATERIAL
1	Body	AISI 316L / 1.4404
2	Cover	AISI 316L / 1.4404
3	*Clamp	AISI 316L / 1.4404
4	*Seal	Viton
5	Internals	AISI 316L / 1.4404

* Available spare parts.

EN 10204 3.1 certificate available if requested along with the order.

Remarks: FDA/USP Class VI seals certificate on request.

All separators have a serial n°. In cases of non standard separators, this number must be supplied if spare parts are ordered.

