

TDS BLOWDOWN CONTROL VALVES VPC Series

DESCRIPTION

The Adcatrol VPC series control valves are specially designed for the blowdown of steam boilers in order to control the TDS concentration in combination with a TDS controller (BCS series) and probe (SPS series). These valves can also be used for any application where high pressure drop and low flow rates are present.

MAIN FEATURES

Single seated, two way, direct action valve.
Valve top flange permanently attached to the body, removal is unnecessary for replacing the actuator.
Metal to metal hardened sealing as standard.

- OPTIONS:** Pneumatic or electric actuators.
Air filter regulator.
Bottom cover with drain connection.
- USE:** Saturated and superheated steam.
Hot and superheated water.
- AVAILABLE MODELS:** VPC25.
- VALVE SIZES:** DN 15, 20, 25 and 40.
1/2", 3/4", 1" and 1 1/2".
- CONNECTIONS:** Flanged EN 1092-1.
ANSI Class 150 or 300 lb.
- PNEUMATIC ACTUATORS:** PA280.
- ACTUATOR CONN:** 1/4" NPT-F.
- CONTROL SIGNAL:** 0,4 – 2 bar.
- MAX.AIR SUPPLY:** 3,5 bar.
- ELECTRIC ACT.:** AVF234S (consult catalogue IS AV.10 E).



- AMBIENT TEMPERATURE:** -20°C to 70°C.
- STEM SEALING:** PTFE/GR V-Rings – up to 220 °C.
Graphite – up to 300 °C.
- PLUG CHARACTER.:** PL – Linear.
- PLUG DESIGN:** Contoured.
Microflow.
- PORT:** Full port or reduced port.

HOW TO SELECT: Never size the valve according to the pipe diameter in which it has to be fitted, but according to the required actual flow. Refer to the valve calculation data sheet or consult the factory.

CE MARKING – GROUP 2 (PED – European Directive)			
PN40	ANSI 150 lb	ANSI 300 lb	Category
DN 15 to 25	1/2" to 1 1/2"	1/2" to 1"	SEP
DN 40	–	1 1/2"	1 (CE marked)

BODY LIMITING CONDITIONS *					
PN40		ANSI 150 lb		ANSI 300 lb	
ALLOW. PRESS.	RELATED TEMP.	ALLOW. PRESS.	RELATED TEMP.	ALLOW. PRESS.	RELATED TEMP.
40 bar	-10/50°C	19,3 bar	-10/50°C	50 bar	-10/50°C
33,3 bar	200 °C	15,8 bar	150 °C	43,9 bar	200 °C
27,6 bar	300 °C	12,1 bar	250 °C	36,9 bar	350 °C
25,7 bar	350 °C	8,4 bar	350 °C	34,6 bar	400 °C
23,8 bar	400 °C	–	–	–	–

Maximum temperature limited to the valve packing selected;

* Rating according to EN 1092.

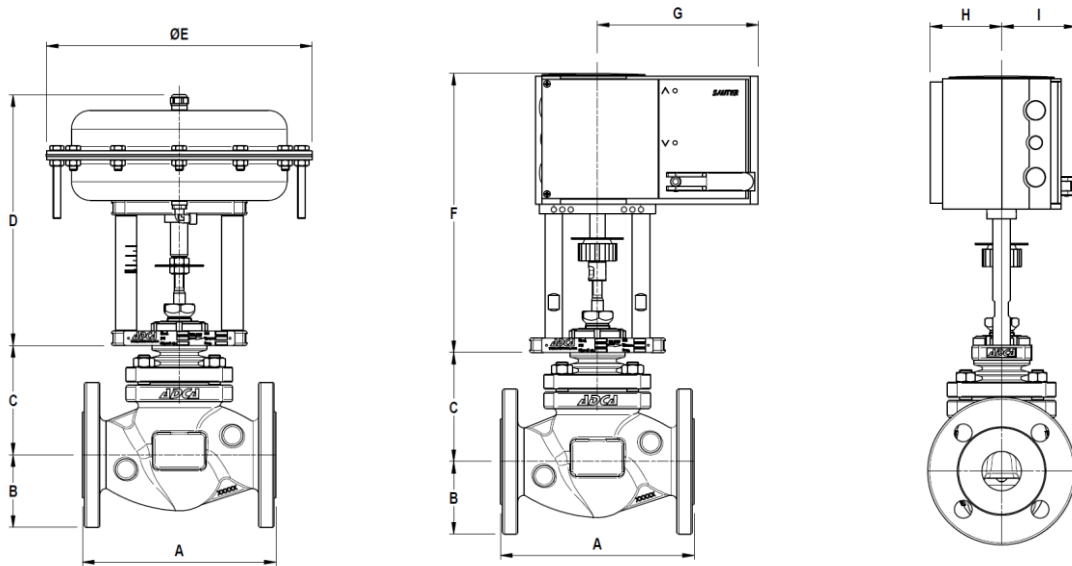

DIMENSIONS – VALVE BODY (mm)				
SIZE	A (mm)	B (mm)	C (mm) BONNET	
			STANDARD	FINNED
1/2" – DN 15	130	48	86	150
3/4" – DN 20	150	53	86	150
1" – DN 25	160	58	90	170
1 1/2" – DN 40	200	75	113	190

DIMENSIONS – ACTUATORS							
TYPE	Ø E (mm)	D (mm)	F (mm)	G (mm)	H (mm)	I (mm)	WGT. (kg)
PA280	275	259	–	–	–	–	8,8
AVF234S	–	–	289	166	72,5	75,5	4,1

MATERIALS		
POS. Nº	DESIGNATION	MATERIAL
1	Valve body	ASTM A216WCB / 1.0619; GP240GH / 1.0619
2	Bonnet	CF8M / 1.4408
3	Valve seat	AISI 316 / 1.4401
4	Valve plug	AISI 316 / 1.4401
5	Valve stem	AISI 316 / 1.4401
6	Spring pin	AISI 301 / 1.4310
7	Body gasket	Stainless steel / Graphite
8	Studs	34CrNiMo6 / 1.6582
9	Nuts	Steel 8.8
10	Standard packing	PTFE/GR
11	Packing nut	AISI 303 / 1.4305
12	Nut	CF8 / 1.4308

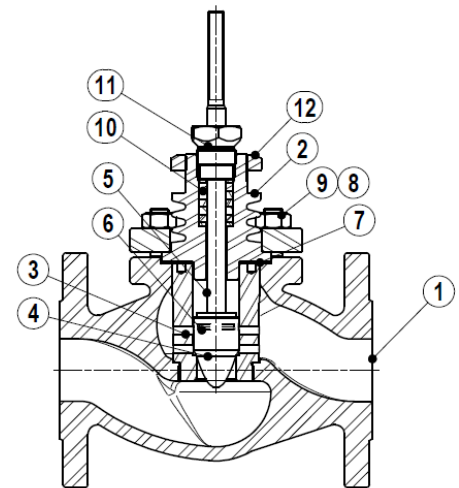

For the actuator materials, see IS PA205.10 E – Linear pneumatic actuators or IS AV.10 E – Linear electric actuators.

Kvs VALUES FOR ADCATROL VPC CONTROL VALVES					
Ø SEAT (MM)	VALVE STROKE (mm)	VALVE SIZES			
		DN 15	DN 20	DN 25	DN 40
4A	20	0,1	–	–	–
4B		0,25	–	–	–
4C		0,5	–	–	–
8A		1	1	–	–
8B		1,7	1,7	–	–
12A		2,1	2,5	3	–
12B		2,7	3,7	4	–
15A		3,8	4,7	5,8	6,8
20A		–	5,1	6,3	9,3
25A		–	–	9,4	14,6

Letters after the seat diameter are for codification purposes only.

For conversion $Kvs = Cv(US) \times 0,855$.

MAX. PERM. PRESSURE DROP (bar) – N.C. (Fluid to open) – Reverse action actuator (air signal to open)

ACTUATOR	CONTROL SIGNAL	SIZES			
		DN 15	DN 20	DN 25	DN 40
PA280	0,4 ÷ 2 bar	40	40	35	25

The pressure drop values must be used within the body rating limits.

MAX. PERM. PRESSURE DROP (bar) – Fail safe electric actuator (stem extends)

ACTUATOR	SIZES			
	DN 15	DN 20	DN 25	DN 40
AVF234S	40	40	28	9,9

The pressure drop values must be used within the body rating limits.

CALCULATING THE AMOUNT OF BOILER BLOWDOWN

The boiler blowdown system design depends on the amount of boiler water which has to be blown down. This amount depends on:

(Rs) – Recommended boiler water TDS in ppm (parts per million) or $\mu S/cm$. Usually recommended by the boiler manufacturer or water treatment specialist.

(Fs) – Feed water TDS (same units as Rs). Sample for analysis must be taken from fresh water feed tank or feed water line. Do not use a sample of the make-up feed water, or wrong values can be obtained.

(Q) – Steam boiler maximum flow rate in kg/h.

(Br) – The blowdown rate or amount of water to be discharged, in kg/h. Can be obtained using the following formula:

$$Br = Q \cdot Fs / (Rs - Fs)$$

Example:

Boiler pressure: 12 bar;

Q - Boiler capacity: 12 000 kg/h;

Fs - Conductivity of feed water: 100 $\mu S/cm$;

Rs - Recommended boiler water TDS: 3000 $\mu S/cm$;

$$Br = 12000 \cdot 100 / (3000 - 100); Br = 413,8 \text{ kg/h}$$

Using the formula available in IS PV10.00 E, it is now possible to determine the necessary Kv valve and select the right valve size.

TYPICAL INSTALLATIONS

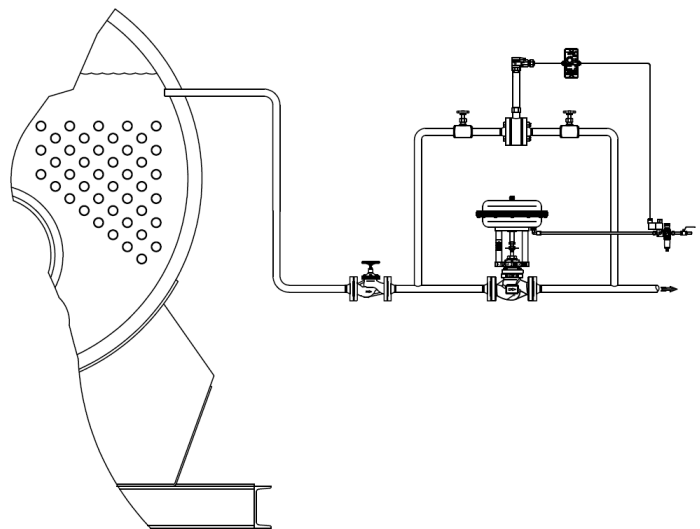
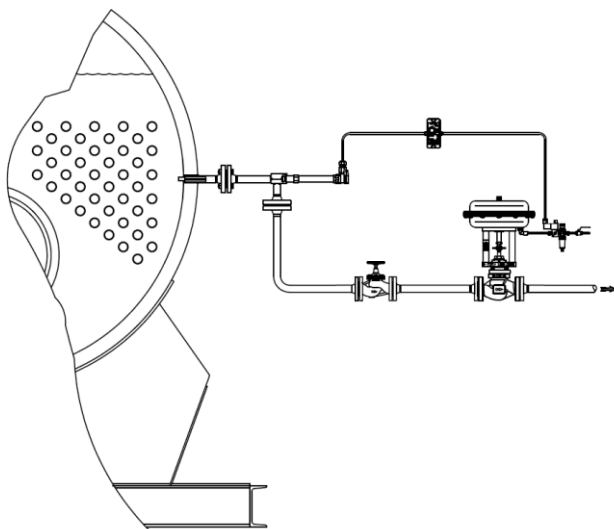

ORDERING CODES VPC									
VALVE CODES	VPC	25.	1	8	1	V	15	.X.	
Group designation									
Blowdown control valves, two way, straight body	VPC								
Valve model									
ASTM A216 WCB body, stainless steel trim		25.							
Stem sealing									
PTFE/GR-V-Rings / Standard bonnet			1						
Virgin PTFE V-Rings / Standard bonnet			2						
Graphite / Finned bonnet			4						
Valve plug									
PL (linear) – Stellite				8					
Seat diameter									
4 A						1			
4 B						2			
4 C						3			
8 A						4			
8 B						5			
12 A						7			
12 B						8			
15 A						10			
20 A						13			
25 A						16			
Pipe connection									
Flanged EN 1092-1 PN40							N		
Flanged ANSI B 16.5 150 lb							U		
Flanged ANSI B 16.5 300 lb							V		
Size									
DN 15 or 1/2"								15	
DN 20 or 3/4"								20	
DN 25 or 1"								25	
DN 40 or 1 1/2"								40	
Actuator									(1)
Extras									
Full description or additional codes have to be added in case of non-standard combination.									E

ACTUATOR CODES (PNEUMATIC) *	P.			
Group designation				
Multi-spring, pneumatic linear actuator	P.			
Actuator size				
PA280		3		
Actuator type				
Reverse action (air to open)			R	
Actuator Construction				
Steel construction (painted) – standard				(2)
Stainless steel construction				I
Control signal				
0,4 – 2 bar (6/30 psi)				30

→ To be introduced on ".X.", if supplied in combination with the valve.

REMARKS:

- (1) – Indicate actuator type.
- (2) – Omitted if the standard actuator is selected.

* For electric actuator ordering code, consult our technical department.

ADCATrol control valves are identified by a serial number on a nameplate, located on the actuator yoke.

When ordering spares, always use that serial number. If the valve has non-standard extras the serial number also has an E (extras).