

SG-B-F05MT

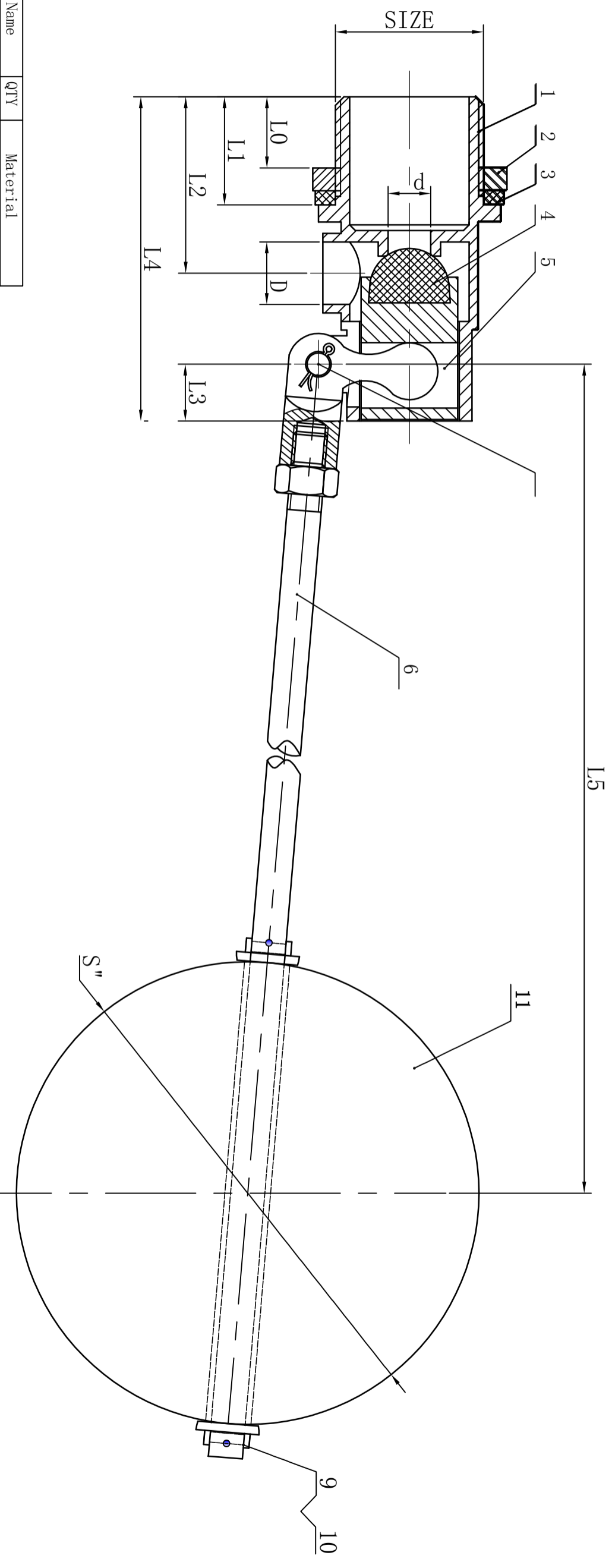

NO.	Part Name	QTY	Material
11	Ball	1	SUS304/SUS316
10	Nuts	1	SUS304/SUS316
9	Gasket	1	SUS304/SUS316
8	Cap	1	SUS304/SUS316
7	Seal	1	PTFE
6	Stem	1	SUS304/SUS316
5	Piston	1	SUS304/SUS316
4	Seal	1	Silicon/NBR/KFM
3	Seal	1	NBR
2	Nuts	1	SUS304/SUS316
1	Body	1	SUS304/SUS316

DN	SIZE	L0	L1	L2	L3	L4	L5	d	D	S''
DN40	1.1/2"22	32	49	38	115	480	22	22	225mm	
DN50	2"	25	36	57	40	128	500	27	27	250mm

FEATURES:

1. Design & Danufacture BS1212-3:1990:ASTM B16. 34
2. Volve Inspecion and Testing nccording tostandard QB/T1199-1991.
3. Thread End: BSP. BSPT. NPT DIN2999. etc

(Verwendungsbereich) (Zul. Abw.) (Oberfl.) Maßstab MAßSTAB (Gewicht)

Name		Date		Maßstab	MAßSTAB	(Gewicht)
Bearb.	BEARBEIT	Datum	NAME			
Gepr.	GEPRÜFT	Norm	NAME			

Float valve

Zust	Änderung	Datum	Name (Urspr.)	(Ers. f.:	(Ers. d.: