

# Multi-stage diffusion silencers

Model 005



During the expansion process for compressible substances such as gases, steam or air, one of the main problems is noise pollution. The noise is caused by opening the valve and discharging the expanded fluid at the speed of sound. Silencers are a great way to reduce this noise, caused by discharging the valve, bringing it down to allowable levels.

They are used in places such as power, chemical and petrochemical plants to discharge safety valves, control valves, etc. in pressure lines and equipment that convey compressible substances such as steam, air, carbon dioxide, helium, methane, nitrogen, oxygen and other gases.

They achieve noise reductions of more than 50 dB without any additional acoustic absorption materials.

## Specifications

- Small, light design. The circular shape absorbs vibrations that could cause damage over time.
- Compact, robust construction permitting liquid expansion and rises in temperature in the silencer, practically without restrictions and without producing stress in the structure.
- A diffuser consisting of a suitable combination of holes and stainless steel wire, preventing vortices when transporting the liquid and of course reducing noise by a minimum of 50 dB.
- At its lowest point, the body houses a discharge pipe for liquids produced by condensation or inclement weather.
- Fitted with anchoring eyes to facilitate their transport and installation.
- Materials carefully selected for resistance to wear, temperature and corrosion. They are fully recyclable.
- No moving parts, guaranteeing minimum maintenance.
- Simple installation.
- Design and specifications in accordance with the requirements of Directive 2014/68/EU and Section VIII, Division 1 of the ASME code. It is not a pressure-sealed receptacle and it cannot have CE or ASME marking.
- Rating plates attached to the body, specifying the design, manufacturing and service conditions.
- Each component is numbered, registered and controlled. If requested beforehand, the silencers will be delivered with certifications of materials, casts, tests and yields.
- Blast finish and two coats of aluminium heat-resistant paint, withstanding temperatures up to 600 °C.

EN ASME/ANSI ASME/FNPT ASME/MNPT ASME/SW

...others to be agreed

**IMPORTANT**

On demand:

- 1.- Supports. Facilitate transport and installation. In the event of movement due to thermal expansion, these supports can absorb the movement if they are low friction.
- 2.- Feet. Supporting materials.
- 3.- Breakwater ring. This discharges rainwater below the liquid input connection to the silencer.
- 4.- Breakwater collar. This discharges rainwater, preventing it from reaching the liquid input connection to the silencer.
- 5.- Adjustable collar. This permits the discharge flow to be directed to the most appropriate area.
- 6.- Heating jacket. Recommended for very cold climates. Prevents freezing of condensate precipitation.
- 7.- Bird protector. This prevents birds and other animals from getting inside the silencer.
- 8.- Environmental protector. This protects the silencer from weather and environmental damage, such as rain, snow, hail, dust, mud and dirt.
- 9.- Extension pipe. Once the required noise level has been obtained, the silencer discharge may be extended to the appropriate point.
- 10.- Connection sensors. To install pressure, temperature and viewing or monitoring sensors.
- 11.- Expansion joints. To absorb movements such as those caused by thermal expansion.
- 12.- Thermal insulation rings. These facilitate the fitting of external insulating materials and, if required, line the silencer in aluminium or stainless steel.
- 13.- Materials. Optional manufacture of other materials for special working conditions (high temperatures, fluids, etc).
- 14.- Specific connections. End for welding, screwing or a flange, that meets EN and ASME standards, among others.

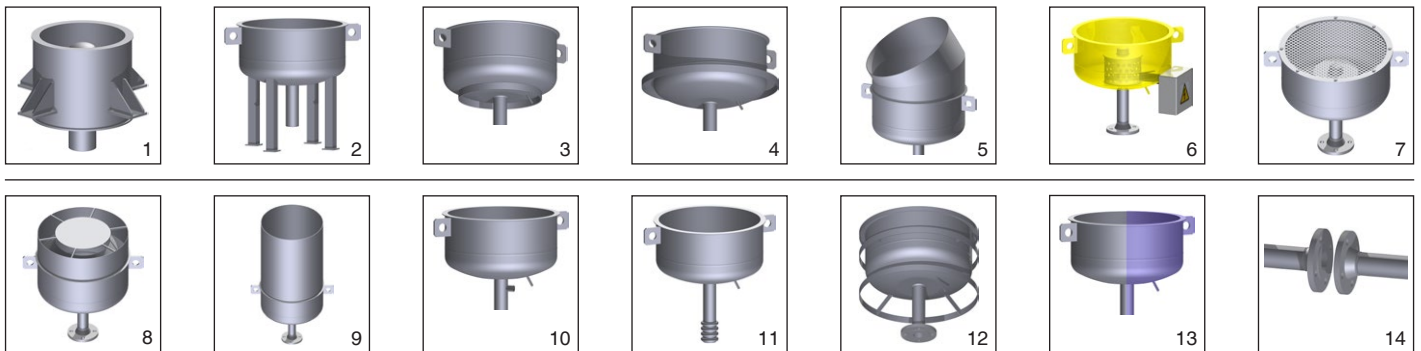

Nº PIECE	PIECE	MATERIAL		
		CARBON STEEL		
		LOW TEMPERATURE	MEDIUM TEMPERATURE	HIGH TEMPERATURE
		LT	MT	HT
1	Input flange	Carbon steel (EN-1.0402)	Carbon steel (EN-1.5415)	Carbon steel (EN-1.7335)
2	Input diffuser tube	Carbon steel (EN-1.0305)	Carbon steel (EN-1.5415)	Carbon steel (EN-1.7335)
3	Diffuser tube	Carbon steel (EN-1.0305)	Carbon steel (EN-1.5415)	
4	Mesh	Stainless steel (EN-1.4301)		Stainless steel (EN-1.4541)
5, 6	Diffuser cover	Carbon steel (EN-1.0425)	Carbon steel (EN-1.5415)	
7	Shell	Carbon steel (EN-1.0425)	Carbon steel (EN-1.5415)	
8	Diffuser tube cover	Carbon steel (EN-1.0305)	Carbon steel (EN-1.5415)	Carbon steel (EN-1.7335)
9	Silencer bottom	Carbon steel (EN-1.0037)	Carbon steel (EN-1.0425)	Carbon steel (EN-1.5415)
10	Drain tube	Carbon steel (EN-1.0305)		
11, 19	Silencer body	Carbon steel (EN-1.0037)	Carbon steel (EN-1.0425)	Carbon steel (EN-1.5415)
12, 20, 21	Coupling reinforcement	Carbon steel (EN-1.0037)	Carbon steel (EN-1.0425)	Carbon steel (EN-1.5415)
13, 22	Eyes	Carbon steel (EN-1.0037)		
14	Ratings plate	Stainless steel (EN-1.4301)		
15	Noise and heat insulation	Rock wool with fibreglass		
16	Fixing jacket	Stainless steel (EN-1.4301)		Stainless steel (EN-1.4541)
17	Fixing ring	Carbon steel (EN-1.0037)	Carbon steel (EN-1.0425)	Carbon steel (EN-1.5415)
18	Absorbent material	Rock wool with fibreglass		
OPERATING CONDITIONS	MAXIMUM TEMPERATURE IN °C	400	510	540
	MAXIMUM TEMPERATURE IN ° F	750	950	1000

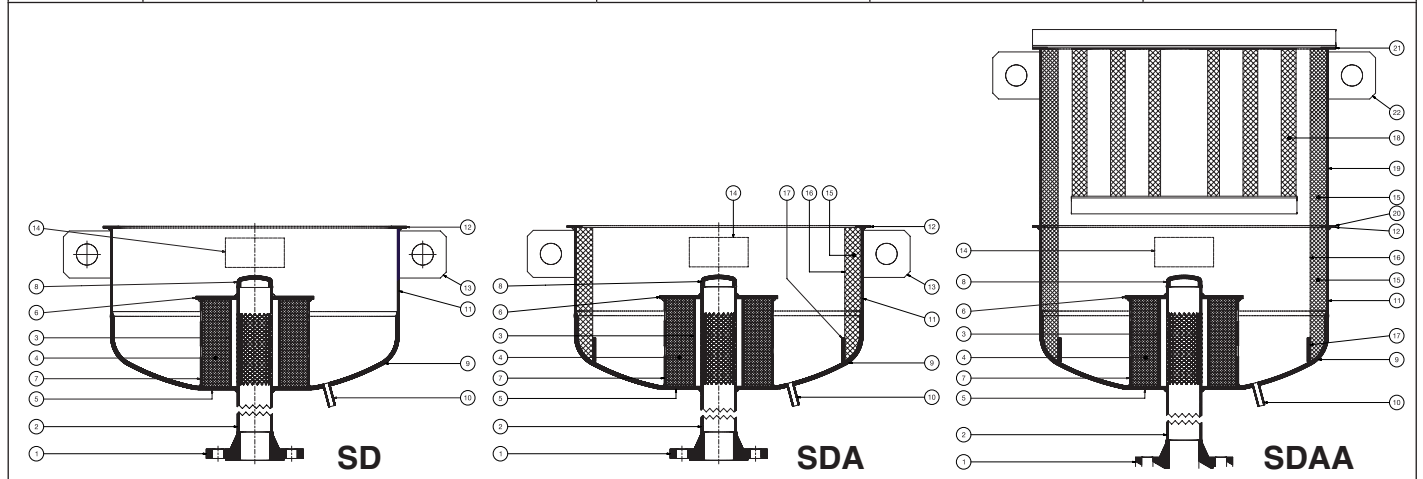

**Operation**

When the safety valve is triggered, the liquid expands in the input diffuser pipe (2 and/or 3). A suitable combination of small holes produces a primary expansion in (2) and, depending on the load loss, a second expansion in (3) may occur. The perfect setup of the second expansion with respect to the first one is vital.

As the liquid passes through the diffuser and expands it produces turbulence. A stainless steel mesh (4) is fitted to prevent turbulence and absorb and thus reduce the discharge noise level.

The diffuser silencer partially absorbs the load loss from the valve to the silencer, making noise reduction easier to control.

The standard design can provide noise reduction levels of up to 50 dB.

To achieve higher noise reduction levels at an initial stage, noise and heat insulation materials (15) should be fitted inside the silencer body (11).

To obtain higher noise reduction levels or for the silencer's resistance absorption to be very low an absorption silencer should be attached to the diffuser silencer with noise and thermal insulation. This multi-stage system meets any noise requirements with a safe, cheap and reliable design.

Various outlets may be connected to one collector, with only this one being fitted with a silencer.

The silencer should be designed to withstand the maximum load that can be produced simultaneously.

Given the following situation:

- 1- Discharge or venting from start-up.
- 2- Steam boiler safety valve.
- 3- Over-heating safety valve.

Discharge or venting from start-up never coincides with discharge of the safety valves.

Discharge or venting requires a basically soundproof design.

Simultaneous discharge of the valves also requires a resistance design.

Several valves with different trip pressures can be connected to a discharge collector, but the valve with the highest pressure may affect the other valves. Therefore, the pressures must be equalised at the collector input. This is achieved by fitting diffuser pipes to the collector inputs.

These diffuser pipes have a number of perforations whose diameter and density are calculated to reduce and equalise pressure.

Much higher noise reduction levels may be obtained if a silencer downstream from the diffuser is fitted with sound absorbent systems.

The silencer can be smaller and cheaper as long as the valve permits a degree of counter pressure. However, if the valve does not permit counter pressure or is restricted, this must be taken into consideration in the calculations.

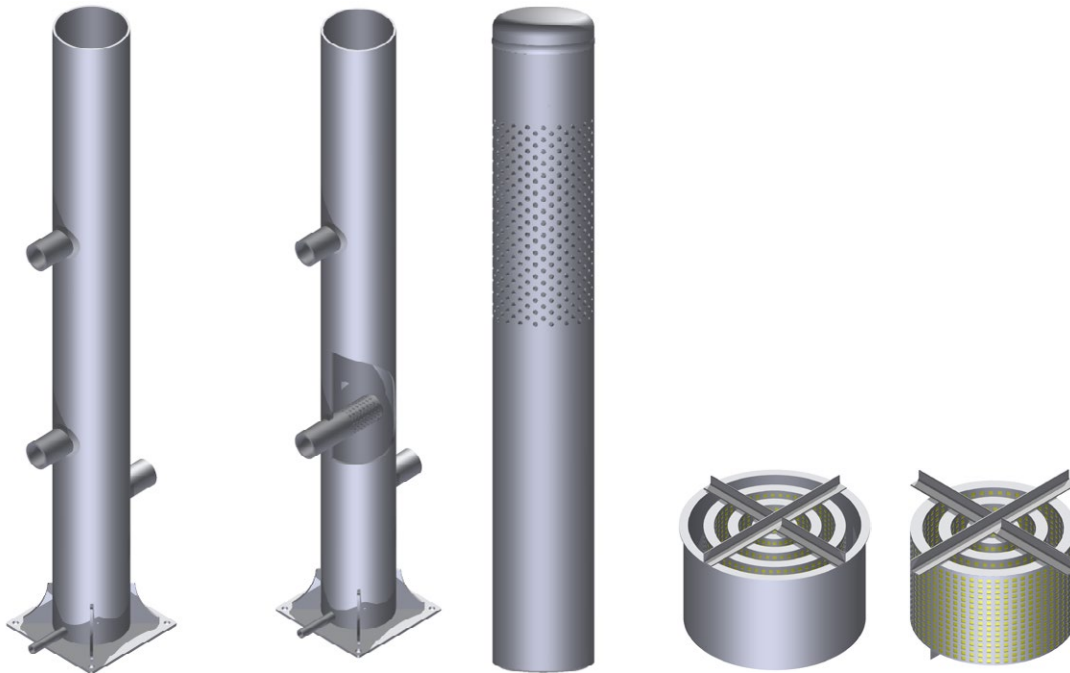
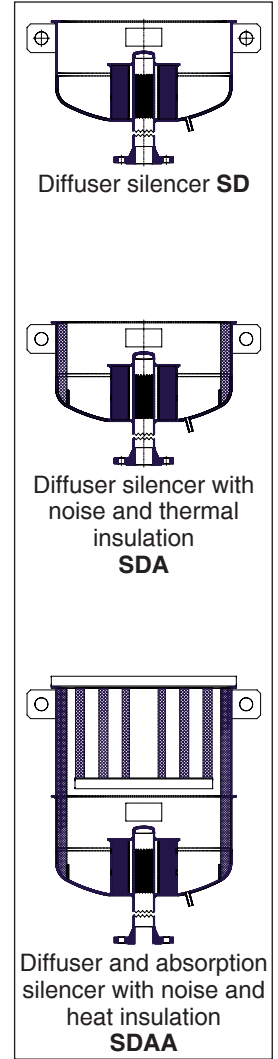

Discharge collector

Discharge collector with diffuser pipes

Sound absorber

## Installation

If possible, fit the silencer at the highest possible point, well removed from inhabited zones, and never stuck to walls that could act as noise reflectors, and thus guarantee the highest levels of noise reduction and safety for personnel and installations.

Take precautions with respect to the discharge liquid as it may be toxic or hazardous.

Fitting the silencer indoors is completely prohibited.

We recommend that the silencer connector pipe should be large enough to keep the flow of discharge liquid below Mach 0.2 and thus guarantee minimum noise reduction.

The diameter of the pipe should be as straight and even as possible to prevent noise due to turbulence. If this is not possible, the discharge pipe must be fitted with noise insulation. If not, the sound reduction performance of the silencer will be affected.

In special designs where there is counter pressure generated upstream from the silencer, this counter pressure must be taken into account.

In most cases the valve discharge pipe itself serves as the silencer support. In exceptional cases, we offer a wide range of supports to meet all types of requirements and guarantee safe, flexible silencer installation.

### Examples:

1- Installation on a roof. Consider the roof load, thermal expansion and wind forces.

2- On a roof with considerable wind force and large silencers, assembly supports may be used.

Where there is also thermal expansion, the drain pipe can be suspended so that it slides or can be fitted with an expansion compensator.

Remember it is recommendable for the drain pipe to lead to a drain, and thus prevent build-up of dirt and ensure a good silencer setup. For installations in low-temperature areas, the pipe must be thermally insulated to prevent freezing.

Store the silencers with protective plugs for the connections, preferably in clean, covered areas.

On start-up, clean the silencer with compressed air and carry out a pre-rinse.

Any additional precautions for the specific silencer design will be specified in the supplementary technical instructions provided on delivery of the product.

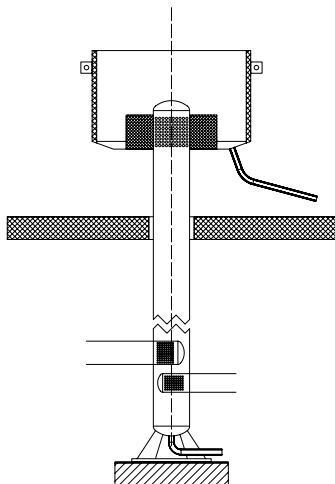

## Insulation

There are two types of insulation to be considered for a silencer and the ideal method is for both to be combined in a single insulation.

**1-Noise insulation.** Silencers reduce noise transported by the discharge flow, but at the same time the noise generated by the discharge valve, the discharge line and the silencer casing need to be reduced.

Documentation is available on the noise generated by gases and steam when flowing and on noise reduction in the discharge pipe, considering DN, pressure and pipe length.

For a fast estimate with an accuracy of  $\pm 2$ dB, it is often enough to rely on this documentation, but a more exact calculation must consider:

- Internal pipe diameter
- Pipe thickness
- Pipe length in its transmission area
- Pressure inside the pipe
- The density of the liquid

The noise produced by an uninsulated pipe, which discharges onto the roof of a boiler room can be estimated for a point P1 at a lateral distance of 1 metre from the pipe, calculating the noise level generated by the discharge valve flow and subtracting the noise reduction produced by the length of the discharge pipe.

In the case of an installation with an identical discharge pipe but which is external along its whole length, the noise level at the same point P1 is 10dB higher.

Example calculation

Installation of a safety valve DN-65x100

Liquid Superheated steam

Flow: 50 t/h

Temperature: 500 °C

Trip pressure: 10 bar.

Permitted 9% counter pressure: 9 bar.

A silencer is fitted that reduces noise levels  $L_r$  of the energy at reference point R at 96 dB (A).

If the internal noise of the valve is calculated:

$$L_{wv} = 17 \times \log(50) + 50 \times \log(273 + 500) - 15 = 158.3 \text{ dB (A)}$$

For a discharge pipe diameter of 300 mm at the 9 bar limit, there is a reduction of  $D_i = 42$  dB in a 10-m section.

The noise level at observation point LP1

$$LP1 = L_{wv} - D_i = 116.3 \text{ dB (A)}$$

The noise level near the uninsulated discharge pipe is  $LP1 = 116.3$  dB (A)

The noise level at the silencer output  $L_r = 96$  dB (A)

To obtain the desired noise level, the discharge pipe must be insulated for noise.

### 2- Heat insulation

When the discharge pipe acts as a thermal bridge between the boiler room and outside, heat is being transferred outside with the subsequent energy cost. Meanwhile, probable freezing and condensation in the pipes and silencer make heat insulation advisable for the whole system.

