

Proportional safety valve with spring loading. (AP)

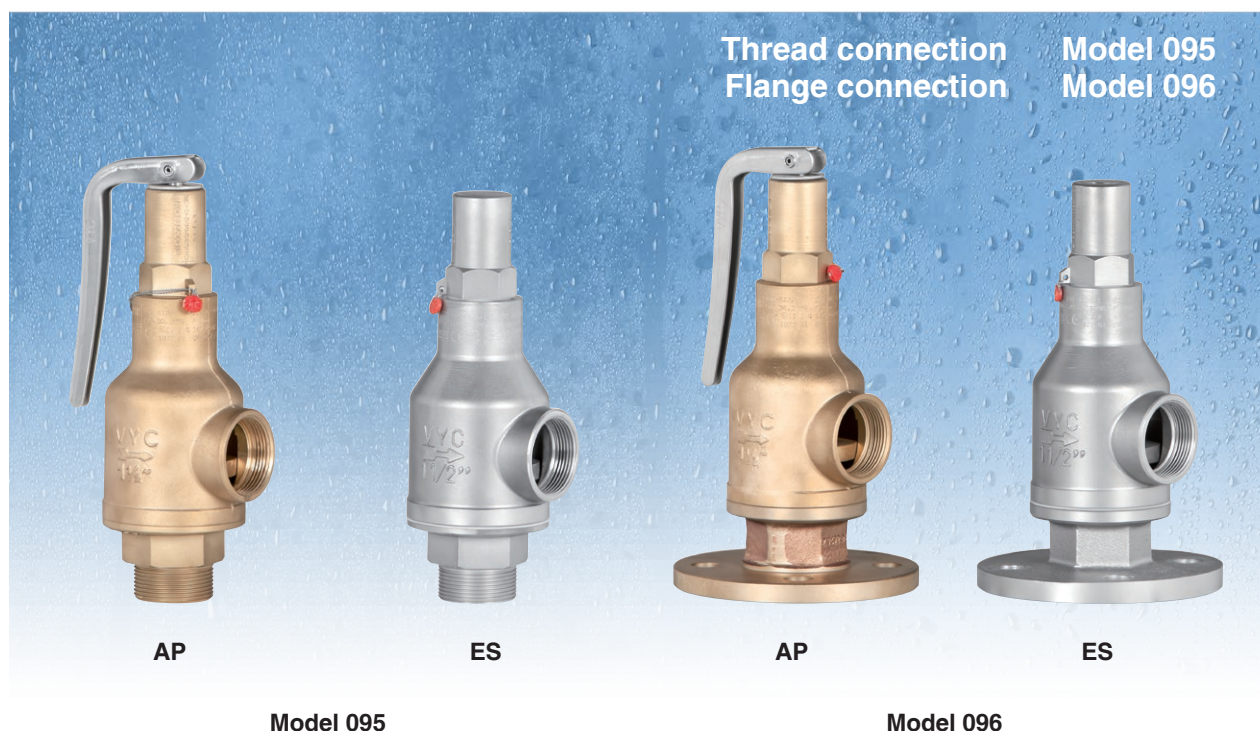

EN



The valve works as an automatic pressure releasing regulator activated by the static pressure existing at the entrance to the valve and is characterized by its ability to open proportional to the pressure increase.

Design in accordance with "International Standard ISO 4126-1 Safety Valves".

In accordance with the requirements of the pressure equipment directive 2014/68/EU.

EC valve verification certified by: TÜV Internacional Grupo TÜV Rheinland, S.L. EC 0035.

Type (Module D) EC examination report nº 33530455 certified by: TÜV Internacional Grupo TÜV Rheinland, S.L.

In compliance with the ATEX 2014/34/EU directive "Protective equipment and systems for use in potentially explosive atmospheres".

Other authorisations: ISCIR, ITI, NASTHOL, EAC, ...etc.

Specifications

- Model AP open cap with lever.
- Model ES closed cap without lever.
- 90° angular flow.
- Activated by direct action helicoid spring.
- Simplicity of construction ensuring minimum maintenance.
- Materials carefully selected for their resistance to corrosion.
- Internal body designed to offer favourable flow profile.
- Seat and sealing disk balanced, making them extremely tightness, even exceeding EN 12266-1 requirements.
- Great discharge capacity.
- Guarantees absolute opening and closing precision.
- Equipped with draining screws for removing condensation. (For $d_0 > 45,20$ mm.).
- Orientation of the lever by rotation.
- All the valves are supplied sealed at the set pressure requested, simulating operational conditions, and are vigorously tested.
- All components are numbered, registered and checked. If requested in advance, material, casting, test and efficiency certificates will be enclosed with the valve, and with the instruction manual, in accordance with P.E.D. 2014/68/EU.

IMPORTANT

1.- Silicone's rubber, Fluorelastomer (Vitón) seals, PTFE (Teflón)... etc., achieving leakage levels less than:

$$0,3 \times 10^{-3} \frac{\text{Pa cm}^3}{\text{seg.}}$$

The ranges of application allow certain flexibility although we recommend limiting them to:

RANGE OF APPLICATIONS OF THE SEALS						
FLUID	SET PRESSURE IN bar					
	0,2	1,5	3,5	4,0	8,0	25,0
Saturated steam	S	V			T	
Liquids and gases	S		V			T
SEALS	TEMPERATURE IN °C					
		ACCORDING TO MANUFACTURERS		RECOMMENDEEN BY VYC		
		MINIMUM	MAXIMUM	MINIMUM	MAXIMUM	
Silicone's rubber	S	-60	+200	-50	+115	
Fluorelastomer (Viton)	V	-40	+250	-30	+150	
PTFE (Teflon)	T	-265	+260	-80	+230 (1)	

(1) For temperatures exceeding 230°C apply metallic seal only.

Depending on demand:

- Buna-nitrils seals, Butyl, Natural rubber, E.P.D.M., Chlorosulphonate polyethylene (Hypalon), Neoprene, etc.
- Seal metal by metal.
- Electrical contact indicating open/closed.
- Other connections.
- Possibility of manufacture in other types of material, for special operating conditions (high temperatures, fluids, etc.).
- Totally free of oil and grease, to work with oxygen, avoiding possible fire risks (UV-Oxygen-VBG62).

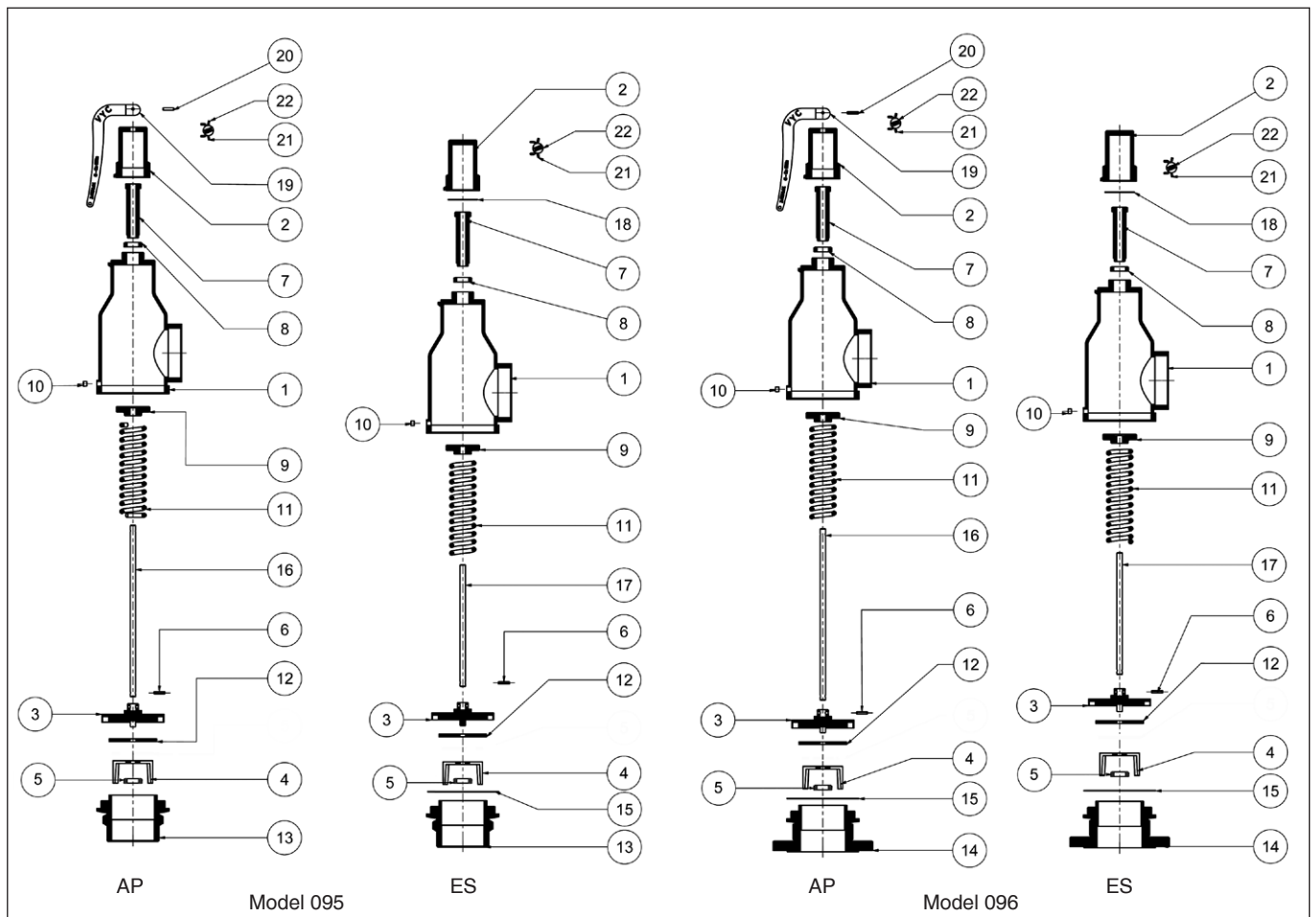

TYPE	Nº. PIECE	PIECE	R ₁ x R ₂	1/4" x 1/4"	3/8" x 3/8"	1/2" x 1/2"	3/4" x 3/4"	1" x 1"	1 1/4" x 1 1/4"	1 1/2" x 1 1/2"	2" x 2"	2 1/2" x 2 1/2"	3" x 3"	4" x 4"	PN	OPERATING CONDITIONS						
			DN ₁ x DN ₂	8 x 1/4"	10 x 3/8"	15 x 1/2"	20 x 3/4"	25 x 1"	32 x 1 1/4"	40 x 1 1/2"	50 x 2"	65 x 2 1/2"	80 x 3"	100 x 4"		A	B	C				
BRONZE / BRASS	1	Body	Brass (EN-CW617N)									*	Bronze (EN-CC761S)			16	16	200	-60			
	2	Cap	Brass (EN-CW617N)									*	Bronze (EN-CC761S)									
	3	Coupling	Brass (EN-CW617N)									Bronze (EN-CC761S)										
	4	Lead	Stainless steel (EN-1.4401)																			
	7	Hollow screw	Brass (EN-CW617N)																			
	8	Hollow screw nut	Brass (EN-CW617N)																			
	9	Spring press	Brass (EN-CW617N)																			
	10	Cap										Brass (EN-CW617N)										
	13	Screwed seat	Brass (EN-CW617N)									Bronze (EN-CC761S)										
	14	Flanged seat	Bronze (EN-CC761S)																			
	15	Body coupling	PTFE (Teflón)																			
	18	Hood coupling	PTFE (Teflón)																			
MIXED	1	Body	Brass (EN-CW617N)									*	Bronze (EN-CC761S)			25	25	200	-60			
	2	Cap	Brass (EN-CW617N)									*	Bronze (EN-CC761S)									
	3	Coupling	Stainless steel (EN-1.4401)																			
	4	Lead	Stainless steel (EN-1.4401)																			
	7	Hollow screw	Brass (EN-CW617N)																			
	8	Hollow screw nut	Brass (EN-CW617N)																			
	9	Spring press	Brass (EN-CW617N)																			
	10	Cap										Brass (EN-CW617N)										
	13	Screwed seat	Stainless steel (EN-1.4408)																			
	14	Flanged seat	Stainless steel (EN-1.4408)																			
	15	Body coupling	PTFE (Teflón)																			
	18	Hood coupling	PTFE (Teflón)																			
STAINLESS STEEL	1	Body	Stainless steel (EN-1.4408)															25	25	250	-60	
	2	Cap	Stainless steel (EN-1.4408) (2)							Stainless steel (EN-1.4408)												
	3	Coupling	Stainless steel (EN-1.4401)																			
	4	Lead	Stainless steel (EN-1.4401)																			
	7	Hollow screw	Stainless steel (EN-1.4305)																			
	8	Hollow screw nut	Stainless steel (EN-1.4305)																			
	9	Spring press	Stainless steel (EN-1.4301)																			
	10	Cap										Stainless steel (EN-1.4401)										
	13	Screwed seat	Stainless steel (EN-1.4408)																			
	14	Flanged seat	Stainless steel (EN-1.4408)																			
	15	Body coupling	PTFE (Teflón)																			
	18	Hood coupling	PTFE (Teflón)																			
		5	Nut	Stainless steel (EN-1.4401)																		
		6	Clip	Stainless steel (EN-1.4310)																		
		11	Spring	Stainless steel (EN-1.4310) (1)																		
		12	Sealing disk	PTFE (Teflón)																		
				Silicone's rubber																		
				Fluorelastomer (Vitón)																		
	16,17	Rod	Stainless steel (EN-1.4301)																			
	19	Lever	Stainless steel (EN-1.4301)																			
	20	Clip	Stainless steel (EN-1.4310)																			
	21	Sealing wire	Sealing wire																			
	22	Seal	Plastic																			

(1) Spring steel (EN-10270-1-SH) for wide spring $\varnothing > 10$ mm. but < 14 mm.
Vanadium chrome steel (EN-1.8159) for wide spring $\varnothing > 13$ mm.

(2) With a welded stainless steel flap (EN-1.4301).

* Brass (EN-CC754S-GM).

• Brass (EN-CW617N).

A = PRESSURE IN bar

B = MAX. TEMP. IN °C

C = MIN. TEMP. IN °C

DISASSEMBLY AND ASSEMBLY

1 – Disassembly

To replace the spring (11), or clean any of the internal components of the valve, proceed in the following manner:

A – Withdraw the clip (20), using a punching tool, and lift the lever (19).

B – Unscrew the cap (2) and remove.

C – Holding the rod (16) (17) steady, loosen the hollow screw nut (8), until the constructive limit, and the hollow screw (7) until you note a releasing of the spring (11).

D – Unscrew the body (1) holding the rod (16) (17) and the seat (13) (14) steady.

E – Lift the body (1) and you will have acces to all the components.

2 – Assembly

A – Enter the body (1) and the joint (15) through the upper part the rod (16) (17).

B – Turn the body (1) holding the rod (16) (17) and the seat (13) (14) steady.

C – Replace the hollow screw (7) with the hollow screw nut (8).

D – Adjust the set pressure with the hollow screw (7) and fix the adjustment position with the hollow screw nut (8).

E – Change the coupling (18) and lightly tighten the cap (2).

F – Place the lever (19) and fix it with the clip (20).

ADJUSTING THE SET PRESSURE

A – Proceed according to DISASSEMBLY A, B, C.

B – Proceed according to ASSEMBLY D, E, F.

WARNING

In case to do the change of the sealing disc (12) make sure that the surface of this as well as the one of the seat (13) (14) the correctly rectified and free of impurities.

R1 x R2 DN1 x R2	1/4" x 1/4"	8 x 1/4"	3/8" x 3/8"	10 x 3/8"	1/2" x 1/2"	15 x 1/2"	3/4" x 3/4"	20 x 3/4"	1" x 1"	25 x 1"	1/4" x 1 1/4"	32 x 1 1/4"	1 1/2" x 1 1/2"	40 x 1 1/2"	2" x 2"	50 x 2"	2 1/2" x 2 1/2"	65 x 2 1/2"	3" x 3"	80 x 3"	4" x 4"	100 x 4"
MODEL	095 AP 095 ES	096 AP	095 AP 095 ES	096 AP 096 ES	095 AP 095 ES	096 AP 096 ES	095 AP 095 ES	096 AP 096 ES	095 AP 095 ES	096 AP 096 ES	095 AP 095 ES	096 AP 096 ES	095 AP 095 ES	096 AP 096 ES	095 AP 095 ES	096 AP 096 ES	095 AP 095 ES	096 AP 096 ES	095 AP 095 ES	096 AP 096 ES	095 AP 095 ES	096 AP 096 ES
d0	10,20		10,20		16,20		20,80		25,20		32,20		38,20		45,20		60,20		75,20		95,20	
$A_0 = \frac{\pi \cdot d_0^2}{4} \cdot S$	29,50		29,50		120,30		207,50		347,10		543,00		780,40		1157,60		2155,60		3161,40		5452,10	
H	095 AP 095 ES	096 AP 096 ES	095 AP 095 ES	096 AP 096 ES	095 AP 095 ES	096 AP 096 ES	095 AP 095 ES	096 AP 096 ES	095 AP 095 ES	096 AP 096 ES	095 AP 095 ES	096 AP 096 ES	095 AP 095 ES	096 AP 096 ES	095 AP 095 ES	096 AP 096 ES	095 AP 095 ES	096 AP 096 ES	095 AP 095 ES	096 AP 096 ES	095 AP 095 ES	096 AP 096 ES
h1	35		35		38		42		46		55		62		80		86		100		112	
L1	30		30		32		35		38		44		55		70		75		90		105	
L2	43	52	43	52	52	67	61	69	72	79	80	88	91	98	110	113	125	125	136	138	163	163
R	-		-		-		-		-		-		-		-		1/8"		1/8"		1/8"	

CONNECTIONS

Whitworth cylindrical Male x Female thread ISO 228/1 1978 (DIN-259)

IN TAKE FLANGE	* PN-16 EN 1092-3 • PN-25 EN 1092-1	D1	-	80	-	90	-	95	-	105	-	115	-	140	-	150	-	165	-	185	-	200	-	220* 235•																
		K1	-	55	-	60	-	65	-	75	-	85	-	100	-	110	-	125	-	145	-	160	-	180* 190•																
		l1	-	11,50	-	14	-	14	-	14	-	14	-	14	-	18	-	18	-	18	-	18	-	18	-	18* 22•														
		b1	BRONZE BRASS	-	12	-	12	-	12	-	12	-	12	-	14	-	14	-	16	-	16	-	18	-	18	-	20													
		MIXED S.STEEL	-	14	-	16	-	16	-	18	-	18	-	18	-	18	-	20	-	20	-	22	-	24	-	24														
DRILLS N°.	-	4	-	4	-	4	-	4	-	4	-	4	-	4	-	4	-	4	-	4*	-	8	-	8																
WEIGHT IN kgs.	BRONZE/BRASS	0,60	0,62	1,05	0,98	0,61	1,25	1,10	0,83	1,64	1,54	1,05	0,97	2,00	1,90	2,30	2,34	2,15	4,15	4,35	3,76	3,60	6,00	5,60	6,00	5,80	6,90	10,80	11,30	11,00	11,30	16,00	16,00	21,50	21,50	26,10	26,10	28,10	28,10	30,30
	MIXED	0,60	0,50	1,03	0,96	0,60	1,22	1,15	0,80	1,60	1,42	1,04	0,90	1,93	1,87	2,30	2,20	2,01	4,15	4,20	3,70	3,50	5,80	5,30	6,00	5,80	6,80	10,50	10,80	10,60	11,00	16,00	16,00	20,10	21,20	25,00	25,00	27,00	27,00	29,20
	STAINLESS STEEL	0,53	0,46	0,99	0,92	0,55	1,18	1,11	0,70	1,52	1,41	1,01	0,84	1,87	1,74	2,20	2,20	1,80	4,15	4,20	3,17	3,00	5,50	5,00	6,00	5,80	6,70	10,50	10,80	10,60	11,00	16,00	16,00	20,10	21,20	24,50	24,50	26,80	26,80	29,20
CODE	BRONZE/BRASS	2002-095.6042	2002-095.6043	2002-096.6043	2002-096.6043	2002-095.6382	2002-096.6383	2002-096.6383	2002-095.6021	2002-096.6021	2002-096.6023	2002-095.6342	2002-095.6342	2002-096.6343	2002-095.6102	2002-096.6103	2002-096.6103	2002-095.6142	2002-096.6143	2002-095.6143	2002-096.6143	2002-095.6142	2002-096.6142	2002-095.6202	2002-096.6203	2002-095.6202	2002-096.6203	2002-095.6222	2002-096.6223	2002-095.6302	2002-096.6303	2002-095.6302	2002-096.6303	2002-095.6402	2002-096.6403	2002-095.6402	2002-096.6403	2002-095.6402	2002-096.6403	
	MIXED	2002-095.6041	2002-095.6041	2002-096.6041	2002-096.6041	2002-095.6381	2002-096.6381	2002-096.6381	2002-095.5021	2002-096.5021	2002-096.6023	2002-096.6023	2002-095.6341	2002-095.6341	2002-095.5101	2002-096.5101	2002-096.6103	2002-095.6141	2002-096.6141	2002-095.6141	2002-096.6141	2002-095.5121	2002-096.5121	2002-095.5201	2002-096.5201	2002-095.5201	2002-096.5201	2002-095.6221	2002-096.6221	2002-095.6301	2002-096.6301	2002-095.6301	2002-096.6301	2002-095.5401	2002-096.5401	2002-095.5401	2002-096.5401	2002-095.5401	2002-096.5401	
	STAINLESS STEEL	2002-095.6042	2002-095.6043	2002-096.6043	2002-096.6043	2002-095.6382	2002-096.6383	2002-096.6383	2002-095.6022	2002-096.6023	2002-096.6023	2002-096.6023	2002-095.6342	2002-095.6342	2002-096.6343	2002-095.6102	2002-096.6103	2002-096.6103	2002-095.6142	2002-096.6143	2002-095.6143	2002-096.6143	2002-095.6142	2002-096.6142	2002-095.6202	2002-096.6203	2002-095.6202	2002-096.6203	2002-095.6222	2002-096.6223	2002-095.6302	2002-096.6303	2002-095.6302	2002-096.6303	2002-095.6402	2002-096.6403	2002-095.6402	2002-096.6403	2002-095.6402	2002-096.6403

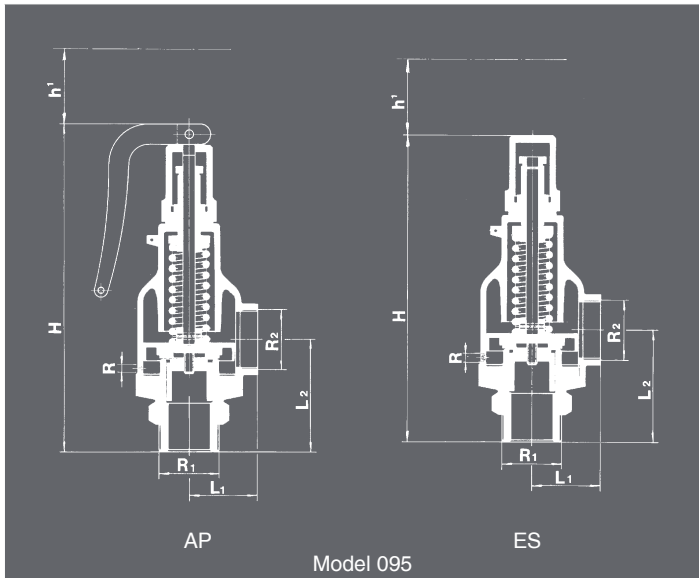

AP

Model 095

ES

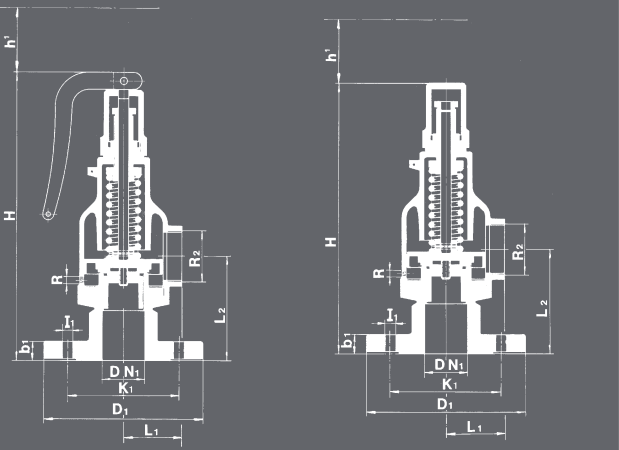

AP

Model 096

ES

SET PRESSURES AND REGULATING RANGES								
R1 x R2 DN1 x R2	SPRING REGULATING RANGE IN bar	CODE	SET PRESSURES IN bar					
			MAXIMUM (LIQUIDS AND GASES)		MAXIMUM (SATURATED STEAM)		MINIMUM	
			PN-16	PN-25	PN-16	PN-25	STEAM & GASES	LIQUIDS (1)
1/4" x 1/4" 3/8" x 3/8" 8 x 1/4" 10 x 3/8"	0,5 at 1,0	56024 •	16	25	13	20	0,5	0,2
	1,1 at 1,9	56025 •						
	2,0 at 3,9	56026 •						
	4,0 at 7,9	56027 •						
	8,0 at 13,4	56028 •						
	13,5 at 19,8	56029 •						
19,9 at 25,0	56030 •							
1/2" x 1/2" 15 x 1/2"	0,5 at 1,0	56033 •	16	25	13	20	0,5	0,2
	1,1 at 2,0	56034 •						
	2,1 at 4,0	56035 •						
	4,1 at 8,0	56036 •						
	8,1 at 12,0	56037 •						
	12,1 at 19,0	56038 •						
19,1 at 25,0	56039 •							
3/4" x 3/4" 20 x 3/4"	0,5 at 1,0	56043 •	16	25	13	20	0,5	0,2
	1,1 at 2,0	56044 •						
	2,1 at 4,0	56045 •						
	4,1 at 6,0	56046 •						
	6,1 at 10,0	56047 •						
	10,1 at 13,2	56048 •						
13,3 at 17,5	56049 •							
17,6 at 25,0	56050 •							
1" x 1" 25 x 1"	0,5 at 1,5	56053 •	16	25	13	20	0,5	0,2
	1,6 at 2,6	56054 •						
	2,7 at 4,0	56055 •						
	4,1 at 7,5	56056 •						
	7,6 at 11,0	56057 •						
	11,1 at 14,5	56058 •						
14,6 at 20,0	56059 •							
20,1 at 25,0	56060 •							
1 1/4" x 1 1/4" 32 x 1 1/4"	0,5 at 1,5	56062 •	16	25	13	20	0,5	0,2
	1,6 at 2,6	56063 •						
	2,7 at 4,0	56064 •						
	4,1 at 7,5	56065 •						
	7,6 at 10,0	56066 •						
	10,1 at 12,5	56067 •						
12,6 at 15,5	56068 •							
15,6 at 19,5	56069 •							
19,6 at 25,0	56070 •							
1 1/2" x 1 1/2" 40 x 1 1/2"	0,5 at 0,8	56073 •	16	25	13	20	0,5	0,2
	0,9 at 2,0	56074 •						
	2,1 at 4,0	56075 •						
	4,1 at 5,5	56076 •						
	5,6 at 8,0	56077 •						
	8,1 at 11,5	56078 •						
11,6 at 15,7	56079 •							
15,8 at 25,0	56080 •							
2" x 2" 50 x 2"	0,5 at 1,0	56083 •	16	25	13	20	0,5	0,2
	1,1 at 2,0	56084 •						
	2,1 at 5,2	56085 •						
	5,3 at 6,7	56086 •						
	6,8 at 11,0	56087 •						
	11,1 at 13,8	56088 •						
13,9 at 18,9	56089 •							
19,0 at 25,0	56090 –							
2 1/2" x 2 1/2" 65 x 2 1/2"	0,5 at 1,5	56092 •	16	25	13	20	0,5	0,2
	1,6 at 5,0	56093 •						
	5,1 at 9,0	56094 •						
	9,1 at 11,8	56095 –						
	11,9 at 15,0	56096 –						
	15,1 at 19,0	56097 –						
19,1 at 25,0	56098 ▲							
3" x 3" 80 x 3"	0,5 at 2,0	56099 •	16	25	13	20	0,5	0,2
	2,1 at 6,0	56100 •						
	6,1 at 8,8	56101 –						
	8,9 at 12,0	56102 ▲						
	12,1 at 18,5	56103 ▲						
	18,6 at 21,5	56104 ▲						
21,6 at 25,0	56105 ▲							
4" x 4" 100 x 4"	0,5 at 2,0	56106 •	16	25	13	20	0,5	0,2
	2,1 at 6,0	56107 –						
	6,1 at 9,0	56108 ▲						
	9,1 at 14,0	56109 ▲						
	14,1 at 19,0	56110 ▲						
	19,1 at 25,0	56111 ▲						

• Stainless steel (EN-1.4310).

– Sprin steel with Epoxi coating (EN-10270-1-SH).

▲ Vanadium chrome steel with Epoxi coating (EN-1.8159).

(1) For set pressures less than 0,5 bar previous consult with our technical department.

COEFFICIENT OF DISCHARGE

R1 x R2 DN1 x R2	1/4" x 1/4" 8 x 1/4"	3/8" x 3/8" 10 x 3/8"	1/2" x 1/2" 15 x 1/2"	3/4" x 3/4" 20 x 3/4"	1" x 1" 25 x 1"	1 1/4" x 1 1/4" 32 x 1 1/4"	1 1/2" x 1 1/2" 40 x 1 1/2"	2" x 2" 50 x 2"	2 1/2" x 2 1/2" 65 x 2 1/2"	3" x 3" 80 x 3"	4" x 4" 100 x 4"
d0	10,20	10,20	16,20	20,80	25,20	32,20	38,20	45,20	60,20	75,20	95,20
h	2,50	2,50	3,00	5,00	6,00	8,50	11,00	12,00	15,00	19,00	28,00
h/d0	0,25	0,25	0,19	0,24	0,24	0,26	0,29	0,27	0,25	0,25	0,29
$A_0 = \frac{\pi \cdot d_0^2}{4} \cdot S$	29,50	29,50	120,30	207,50	347,10	543,00	780,40	1157,60	2155,60	3161,40	5452,10

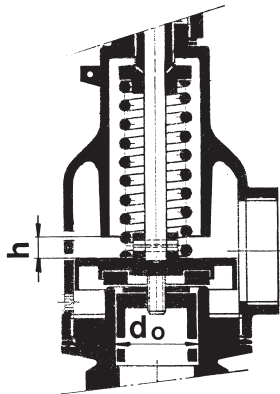

$$A_0 = \frac{\pi \cdot d_0^2}{4} \cdot S$$

S = Lead section

RECOMMENDED RANGES OF APPLICATION

		MODEL	AP	ES
FLUID	SATURATED STEAM		*	
	GASES		*(1)	*
	LIQUIDS		*(1)	*

(1) With noxious or expensive fluids apply only ES model.
If external backpressure exists, the AP model cannot be used.
With external constant backpressure, the spring is adjusted deducting the backpressure from the set pressure.

DISCHARGE CAPACITY

R1 x R2 DN1 x R2	1/4" x 1/4" 8 x 1/4"	3/8" x 3/8" 10 x 3/8"	1/2" x 1/2" 15 x 1/2"	3/4" x 3/4" 20 x 3/4"	1" x 1" 25 x 1"	1 1/4" x 1 1/4" 32 x 1 1/4"
d0	10,2	10,2	16,2	20,8	25,2	32,2
$A_0 = \frac{\pi \cdot d_0^2}{4} \cdot S$	29,50	29,50	120,3	207,5	347,1	543

For other, not so dense liquids, other than water at 20°C apply:

- I - Saturated steam in kg/h.
- II - Air at 0°C and 1,013 bar in [Nm³/h].
- III - Water at 20°C in l/h.

$$V_L = \sqrt{\frac{Q_A}{Q_L}} \cdot V_A \quad \text{and} \quad V_A = V_L \cdot \sqrt{\frac{Q_L}{Q_A}}$$

V_A = Water flow according to table.
V_L = Liquid flow.
Q_A = Water density at a 20°C.
(Q_A = 998 kg/m³)
Q_L = Liquid density.

SET PRESSURE IN bar	I			II			III			I			II			III		
	I	II	III	I	II	III	I	II	III	I	II	III	I	II	III	I	II	III
0,5	25	30	342	25	30	342	42	53	514	51	62	737	58	88	1036	65	123	1290
1,0	39	45	489	39	45	489	63	80	735	77	94	1053	88	133	1480	99	185	1844
1,5	42	51	582	42	51	582	68	94	857	86	106	1228	95	147	1674	114	227	2015
2,0	45	57	675	45	57	675	74	108	980	96	119	1403	102	161	1869	130	270	2187
2,5	50	66	768	50	66	768	83	120	1100	113	131	1590	121	180	2020	152	310	2707
3,0	54	75	861	54	75	861	91	133	1221	130	143	1778	140	199	2170	175	350	3227
3,5	60	85	955	60	85	955	110	145	1342	136	159	1944	154	233	2350	223	387	3468
4,0	66	96	1050	66	96	1050	129	157	1463	143	175	2110	168	268	2530	272	425	3710
4,5	70	106	1127	70	106	1127	137	173	1619	155	197	2282	195	282	2802	288	461	4130
5,0	75	117	1204	75	117	1204	146	190	1775	167	219	2455	222	296	3075	305	497	4551
5,5	79	127	1281	79	127	1281	155	206	1931	179	241	2627	249	310	3347	322	533	4971
6,0	84	138	1359	84	138	1359	164	223	2088	192	264	2800	276	325	3620	339	570	5392
6,5	87	148	1428	87	148	1428	171	255	2191	208	289	2902	300	341	3780	361	606	5690
7,0	91	159	1497	91	159	1497	178	287	2294	224	314	3004	324	358	3940	383	642	5988
7,5	95	169	1566	95	169	1566	185	319	2397	240	339	3106	348	375	4100	405	678	6286
8,0	99	180	1635	99	180	1635	192	352	2500	256	365	3208	372	392	4260	427	715	6584
9,0	107	204	1740	107	204	1740	226	376	2670	296	417	3404	412	442	4588	491	767	7292
10,0	115	228	1845	115	228	1845	260	400	2840	336	470	3600	453	493	4916	556	820	8000
11,0	123	252	1957	123	252	1957	300	426	3000	387	517	3780	506	541	5142	622	890	9010
12,0	132	276	2070	132	276	2070	340	452	3160	439	565	3960	560	590	5368	689	960	10020
13,0	139	301	2167	139	301	2167	372	476	3324	482	607	4102	602	655	5820	732	1042	10535
14,0	147	327	2265	147	327	2265	405	500	3488	526	650	4244	645	720	6272	776	1125	11050
15,0	154	349	2341	154	349	2341	442	526	3624	548	697	4402	683	760	6481	838	1202	11525
16,0	162	372	2418	162	372	2418	480	552	3760	570	745	4560	721	800	6690	900	1280	12000
17,0	169	396	2521	169	396	2521	520	572	3890	610	832	4750	796	883	6945	970	1360	12330
18,0	177	420	2625	177	420	2625	560	592	4020	650	920	4940	872	967	7200	1040	1440	12660
20,0	192	465	2829	192	465	2829	640	644	4360	725	1016	5076	956	1180	7740	1180	1600	13316
22,0		510	3036		510	3036		696	4652		1112	5092		1310	8216		1772	13976
24,0		544	3190		544	3190		750	4808		1184	5416		1415	8598		1896	14560
25,0		579	3345		579	3345		805	4964		1256	5740		1520	8980		2020	15144

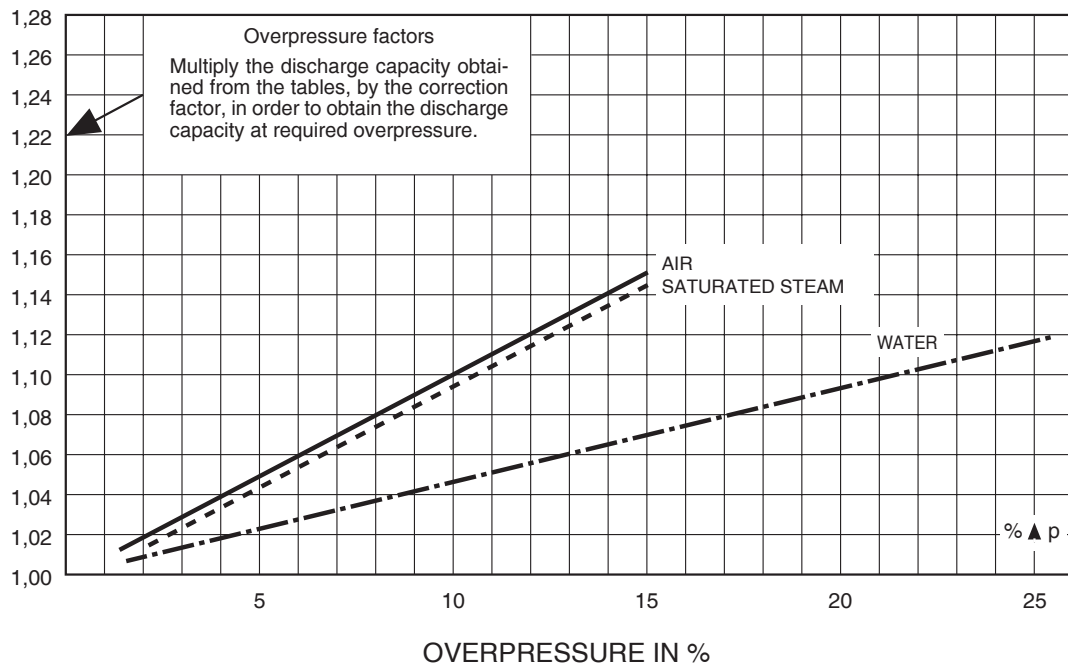

DISCHARGE CAPACITY															
R1 x R2 DN1 x R2	1 1/2" x 1 1/2" 40 x 1 1/2"			2" x 2" 50 x 2"			2 1/2" x 2 1/2" 65 x 2 1/2"			3" x 3" 80 x 3"			4" x 4" 100 x 4"		
d0	38,2			45,2			60,2			75,2			95,2		
$A_0 = \frac{\pi \cdot d_0^2}{4} \cdot S$	780,4			1157,6			2155,6			3161,4			5452,1		
p [bar]															
SET PRESSURE IN bar	I	II	III	I	II	III	I	II	III	I	II	III	I	II	III
0,5	104	176	1930	146	225	2898	188	272	4130	272	335	5201	484	656	6472
1,0	157	266	2758	220	339	4140	284	410	5900	410	505	7430	729	987	9247
1,5	176	310	3242	250	385	4628	318	458	6765	455	557	8307	850	1050	10141
2,0	196	353	3727	280	430	5117	351	507	7630	500	609	9184	972	1113	11035
2,5	234	391	4148	308	475	5540	385	565	8490	554	705	9992	1087	1202	11320
3,0	273	430	4570	336	521	5964	419	623	9350	609	802	10800	1203	1292	11604
3,5	308	463	4931	375	586	6788	454	686	11315	667	861	12453	1326	1376	13742
4,0	343	497	5292	415	652	7612	490	749	13280	725	920	14107	1449	1460	15880
4,5	364	557	5941	444	709	9134	532	809	14685	786	1024	15610	1567	1586	17756
5,0	385	618	6591	473	766	10656	575	870	16090	847	1128	17113	1686	1712	19632
5,5	406	679	7240	502	823	12178	617	931	17495	908	1232	18616	1804	1838	21508
6,0	427	740	7890	532	880	13700	660	992	18900	969	1336	20120	1923	1964	23384
6,5	452	786	8224	570	919	14687	681	1030	19338	1027	1420	20852	2042	2056	23910
7,0	478	832	8559	609	958	15674	702	1068	19776	1086	1504	21585	2161	2148	24437
7,5	503	878	8893	648	997	16661	723	1106	20214	1144	1588	22317	2280	2240	24963
8,0	529	925	9228	687	1036	17648	744	1145	20653	1203	1672	23050	2400	2332	25490
9,0	564	1014	10958	711	1106	19539	802	1215	22812	1327	1854	24373	2641	2414	26081
10,0	600	1104	12688	735	1176	21430	860	1285	24972	1452	2036	25696	2883	2496	26672
11,0	675	1188	13374	807	1258	22365	923	1388	25311	1576	2213	25968	3121	2714	27464
12,0	750	1272	14060	879	1340	23300	987	1492	25650	1700	2390	26240	3360	2932	28256
13,0	806	1358	14715	957	1430	24070	1056	1586	26525	1822	2577	27305	3601	3144	29108
14,0	862	1445	15370	1036	1520	24840	1125	1680	27400	1944	2765	28370	3843	3356	29960
15,0	957	1530	16310	1104	1615	25684	1190	1836	27915	2076	2948	29033	4086	3604	30950
16,0	1052	1615	17250	1172	1710	26528	1256	1992	28430	2209	3132	29697	4329	3852	31940
17,0	1124	1703	17945	1251	1877	27300	1374	2186	29575	2325	3294	31032	4566	4222	32592
18,0	1196	1792	18640	1330	2045	28072	1493	2380	30720	2442	3456	32368	4803	4592	33244
20,0	1292	1995	20230	1452	2385	29870	1590	2512	32456	2685	3812	33030	5295	5162	34936
22,0		2232	21968		2556	31296		2952	35200		4156	36616		5750	38120
24,0		2374	22090		2766	32590		3188	38088		4404	42400		6103	46320
25,0		2516	22212		2976	33885		3424	40976		4652	48184		6456	54520

**FACT LIST FOR
SAFETY VALVE CALCULS**

Calculus according to ISO-4126-1:2004 "Safety valves" 1)

Customer:

Theme:

Leaf:

Of:

1	Consultation / Bid / Order						
2	Position N°.						
3	N°. of units						
4	Regulation						
5	SERVICE CONDITIONS	Fluid					
6		Calculation temperature °C					
7		State at moment of dischar. l = liquid, s = steam, g = gas		<input type="checkbox"/> l <input type="checkbox"/> s <input type="checkbox"/> g	<input type="checkbox"/> l <input type="checkbox"/> s <input type="checkbox"/> g	<input type="checkbox"/> l <input type="checkbox"/> s <input type="checkbox"/> g	
8		Molecular mass kg/kmol					
9		Adiabatic exponent æ	Compressibility coe. Z				
10		Density at moment of discharge kg/m³					
11		Coefficients ψ max	χ				
12		Viscosity cSt	cPs				
13		Working pressure abs. bar					
14		Set pressure abs. bar					
15		External back pressure abs.					
		constant	variable	bar			
16		Rated pressure abs. bar					
17		Discharge	Required: kg/h, Nm³/h, l/h				
18	capacity	Possible: 1) Kg/h, Nm³/h, l/h					
19	VALVE CONSTRUCTION	Opening: Full lift / Normal / Progressive					
20		Manufacturer type					
21		Materials	Body				
22			Seat				
23			Plug				
24			Spring				
25			Joint				
26		Manual discharge action		yes / no			
27		Cover		Closed / Open			
28		Bellows		si / no			
29		Body with drainage		si / no			
30		Diameter of narrowest flow d _o		mm			
31		Section of narrowest flow A _o	Necessary A _o		mm²		
32			Chosen A _o		mm²		
33	Allowed discharge coefficient		α _d				
34	CONNECTIONS	Input / Output	DN	Flange	mm		
35				Thread	inch		
36				Welding (soldering) ends			
37		PN	bar				
38		Shape of joint surfaces (DIN-2526)					
39	OBSERVATIONS	Unit weight		approx. Kg			
40							
41							
42							
43	ACCEPTANCE	Certificate according to		EN-10204 2.2			
44		Certificate according to		EN-10204 3.2			
45							

Date:

Department:

Name: