

# Full lift safety valve with spring loading.(AIT)

Model 486



ASME

Catalog available in International System Units (SI) in PDF format.

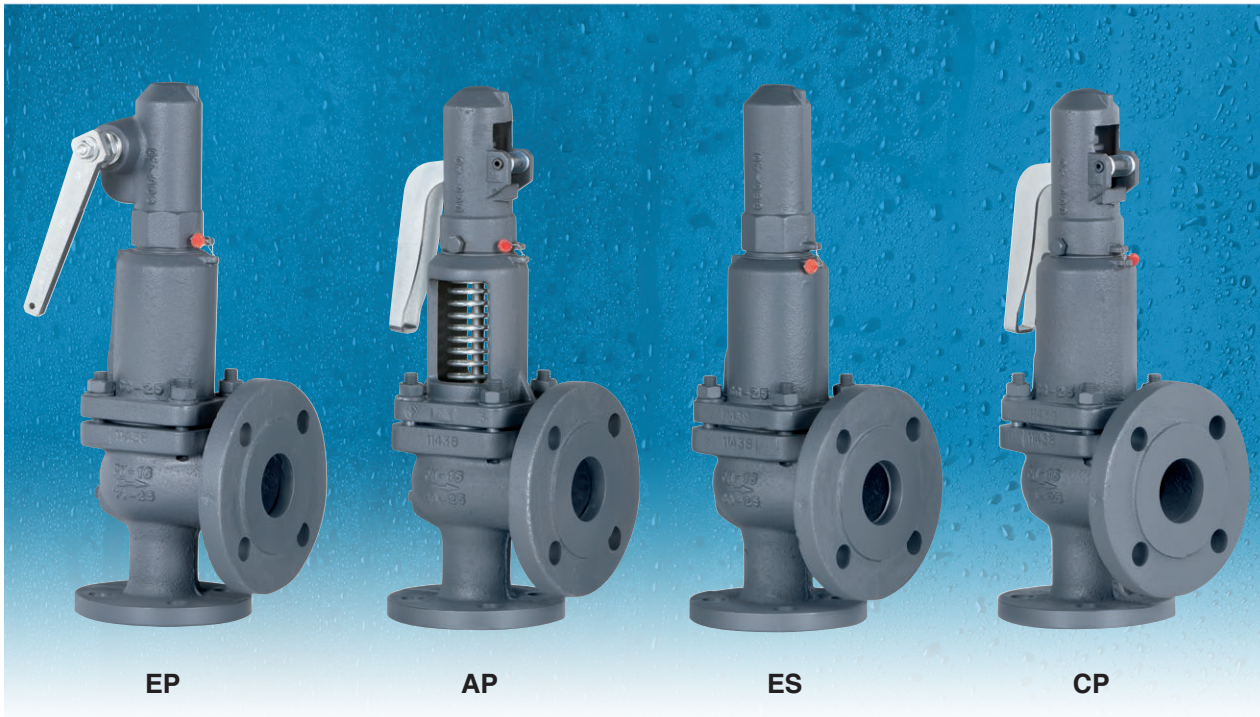

The valve works as an automatic pressure releasing regulator activated by the static pressure existing at the entrance to the valve and is characterized by its ability to open instantly and totally.

Design in accordance with "ASME code section VIII".

Materials according ASME code section II and ASTM. Connections according ASME/ANSI B16.5-2009 standard. Center to face dimensions according API-526.

In accordance with the requirements of the pressure equipment directive 2014/68/EU.

EC valve verification certified by: TÜV Internacional Grupo TÜV Rheinland, S.L. EC 0035.

Type (Module D) EC examination report nº 33530455 certified by: TÜV Internacional Grupo TÜV Rheinland, S.L.

In compliance with the ATEX 2014/34/EU directive "Protective equipment and systems for use in potentially explosive atmospheres".

Other authorisations: ISCIR, ITI, NASTHOL,EAC,...etc.

## Specifications

- 90° angular flow.
- Activated by direct action helioid spring.
- Simplicity of construction ensuring minimum maintenance.
- Materials carefully selected for their resistance to corrosion. With the exception of washers and couplings, the valves are free of non-ferric materials.
- Internal body designed to offer favourable flow profile.
- Sealing surfaces treated and balanced, making them extremely tightness, even exceeding API-527 requirements.
- Great discharge capacity. For liquids typically used with openings similar to proportional safety valves.
- Equipped with draining screws for removing condensation.
- Auto-centering plug.
- Threaded shaft with lever positioner facilitating immediate manual action.
- Elevator, independent of the seal, designed facilitate sudden opening when the steam expands and, with any fluid, guarantees absolute opening and closing precision.
- All the valves are supplied sealed at the set pressure requested, simulating operational conditions, and are vigorously tested.
- All components are numbered, registered and checked. If requested in advance, material, casting, test and efficiency certificates will be enclosed with the valve, and the instruction manual, in accordance with P.E.D. 2014/68/EU.

**IMPORTANT**

Depending on demand:

- 1.- Blocking screw which facilitates hydrostatic testing of the container which to be protected.
- 2.- Rapid limiter to reduce the coefficient of discharge.
- 3.- Fluorelastomer (Vitón) seals, Silicone's rubber, PTFE (Teflón)... etc., achieving leakage levels less than

$$0,2 \times 10^{-8} \frac{\text{psi pulg.}^3}{\text{seg.}}$$

The ranges of application allow certain flexibility although we recommend limiting them to:

RANGE OF APPLICATION FOR THE SEALS					
FLUID	SET PRESSURE IN bar				
	2,90	26,11	58,02	101,53	435,11 580,15
Saturated steam	S	V	T		
Liquids and gases	S	V	T		
SEALS	TEMPERATURE IN °C				
	ACCORDING TO MANUFACTURERS		RECOMMENDED BY VYC		
		MINIMUM	MAXIMUM	MINIMUM	MAXIMUM
Silicone's rubber	S	-76	+392	-58	+239
Fluorelastomer (Vitón)	V	-40	+482	-22	+302
PTFE (Teflón)	T	-445	+500	-112	+446 (1)

(1) For temperatures exceeding 446°F apply metallic seal only

- 4.- Fluorelastomer (Vitón) membrane and O-ring isolating the rotating or sliding parts from the working fluid.
- 5.- Electrical contact indicating open/closed.
- 6.- Balance bellows to:
  - Protect the spring from atmospheric influences.
  - Ensure outside of valve body is totally tightness.
  - Level out external or self-generated back pressure.
- 7.- Possibility of manufacture in other types of material, for special operating conditions (high temperatures, fluids, etc.).
- 8.- Totally free of oil and grease, to work with oxygen, avoiding possible fire risks (UV-Oxygen-VBG 62).
- 9.- Special springs for critical temperatures.

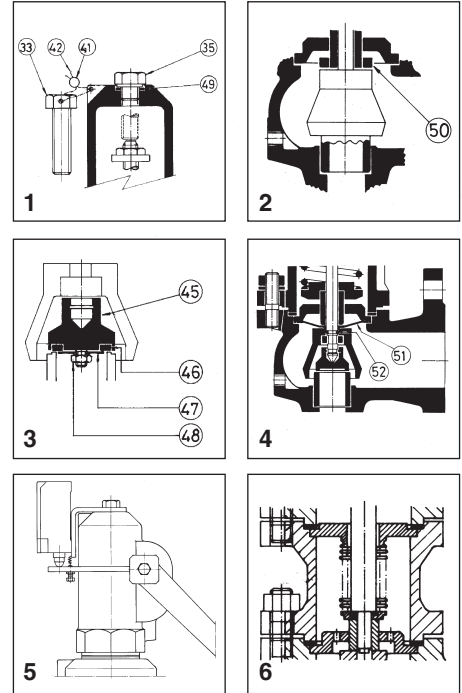

N° PIECE	PIECE	MATERIAL											
		CAST STEEL						STAINLESS STEEL					
1	Body	Cast steel (ASTM A216 - WCB)						Stainless steel (ASTM A 351 - CF8M)					
2	Closed bell	Nodular iron (ASTM A536 65 - 45 -12)						Stainless steel (ASTM A 351 - CF8M)					
3	Open bell	Cast steel (ASTM A 216 - WCB)						Stainless steel (ASTM A 351 - CF8M)					
4, 5, 6	Hood	Nodular iron (ASTM A 536 65 - 45 -12)						Stainless steel (ASTM A 351 - CF8M)					
7	Elevator	Nodular iron (ASTM A 536 65 - 45 -12) (1)						Stainless steel (ASTM A 351 - CF8M) (7)					
8	Cam	Carbon steel (ASTM A 570 - 36) (6)						Stainless steel (AISI 304)					
9, 10	Lever	Carbon steel (ASTM A 570 - 36)						Carbon steel (ASTM A 570 - 36)					
11	Seating	Stainless steel (AISI 420)						Stainless steel (AISI 630)					
12	Plug	Stainless steel (AISI 420)						Stainless steel (AISI 630)					
13	Lead	Stainless steel (AISI 420) (4)						Stainless steel (AISI 316) (5)					
14	Spring press	Carbon steel (AISI 1045)						Stainless steel (AISI 303)					
15	Separator	Stainless steel (AISI 420)						Stainless steel (AISI 316)					
16	Rod	Stainless steel (AISI 420)						Stainless steel (AISI 316)					
17	Lever shaft	Carbon steel (AISI 1045)						Stainless steel (AISI 303)					
18	Gudgeon	Carbon steel (AISI 1070)						Stainless steel (AISI 301)					
19	Ring	Stainless steel (AISI 420)						Stainless steel (AISI 316)					
20, 21	Safety ring	Stainless steel (AISI 301)						Stainless steel (AISI 301)					
22	Spring	Vanadium chrome steel (AISI 6150) (2)						Stainless steel (AISI 301) (3)					
23	Gland	Carbon steel (AISI 1045)						Stainless steel (AISI 303)					
24	Hollow screw	Stainless steel (AISI 303)						Stainless steel (AISI 303)					
25	Hollow screw nut	Stainless steel (AISI 303)						Stainless steel (AISI 303)					
26	Buffer nut	Stainless steel (AISI 303)						Stainless steel (AISI 303)					
27	Rod check nut	Carbon steel (AISI 1015)						Stainless steel (AISI 316)					
28, 29, 48	Nut	Carbon steel (AISI 1015)						Stainless steel (AISI 316)					
30, 31	Washer	Carbon steel (AISI 1015)						Stainless steel (AISI 316)					
32	Stud	Carbon steel (AISI 1035)						Stainless steel (AISI 316)					
33, 34, 35	Screw	Carbon steel (AISI 1045)						Stainless steel (AISI 316)					
36	Cap	Carbon steel (AISI 1035)						Stainless steel (AISI 316)					
38	Coupling	Graphite						PTFE (Teflon)					
39	Coupling	PTFE (Teflon)						PTFE (Teflon)					
40	Seal	Graphite						PTFE (Teflon)					
41	Seal	Plastic						Plastic					
42	Sealing wire	Sealing wire						Sealing wire					
43	Characteristic plate	Stainless steel (AISI 304)						Stainless steel (AISI 304)					
45	Plug	Stainless steel (AISI 316)						Stainless steel (AISI 316)					
46	Sealing disk	PTFE (Teflon)						PTFE (Teflon)					
		Silicone's rubber						Silicone's rubber					
		Fluorelastomer (Viton)						Fluorelastomer (Viton)					
47	Washer	Stainless steel (AISI 316)						Stainless steel (AISI 316)					
49	Coupling	Copper						PTFE (Teflon)					
50	Limiter	Stainless steel (AISI 420)						Stainless steel (AISI 316)					
51	Membrane	Fluorelastomer (Viton)						Fluorelastomer (Viton)					
52	O-ring	Fluorelastomer (Viton)						Fluorelastomer (Viton)					
NPS <sub>1</sub> x NPS <sub>2</sub>		1"x2" to 8"x10"											
Class		150 lbs						150 lbs					
OPERATING CONDITIONS	PRESSURE IN psi	245,11	200,15	175,50	147,94	121,83	94,27	66,72	226,84	198,70	147,94	66,72	
	MAX. TEMP. IN °F	248	392	482	572	662	752	842	248	392	572	842	
	MIN. TEMP. IN °F	-20,2						-20,2					
Class		300 lbs						300 lbs					
OPERATING CONDITIONS	PRESSURE IN psi	580,15	580,15	580,15	577,25	545,34	503,28	333,59	590,59	517,79	458,32	417,70	
	MAX. TEMP. IN °F	248	392	482	572	662	752	842	248	392	572	842	
	MIN. TEMP. IN °F	-20,2						-20,2					

(1) 1"x2" in stainless steel (ASTM A351 CF8M).  
 (2) Spring steel (ASTM A228) for wire spring Ø < 0.4 in. Maximum temperature EP, ES and CP 482°F / AP 752°F.  
 (3) Vanadium chrome steel (AISI 6150) for wire spring Ø > 0.4 in.  
 (4) 8" x 10" in Stainless steel (ASTM A743 CA40F).  
 (5) 8" x 10" in Stainless steel (ASTM A351 CF8M).  
 (6) 1"x2" in Stainless steel (AISI 304).  
 (7) 11/2"x2" to 4"x6" L in Stainless steel (AISI 316)

## Full lift safety valve with spring loading (AIT) model 486 - AP and CP.

### 1. Disassembly and assembly.

#### 1.1 Disassembly.

To replace the spring (22) or clean any of the internal components of the valve, proceed in the following manner:

A - Withdraw the clip (18), using a punching tool, until the lever (10) comes free.

B - Loosen the screws (34) and take the cap (6) off.

C - Holding the spindle (16) steady, loosen the hollow screw nut (25) and the hollow screw (24) until you note a releasing of the spring (22).

D - Mark on the spindle (16) the position of the spindle lock-nut (27) and the adjusting nut (26). Loosen them and remove them.

E - Unscrew the nuts (29) and remove them, together with the studs (32) and their washers (30).

F - Lift the cover (3) or (2) and you will have access to all of the components.

#### 1.2 Assembly.

A - Place the safety-ring (20) on the spindle (16) and press it against the gasket (12).

B - In the spindle channel (16) connect the ring (19) and fix it to the security-ring (21). Introduce the elevator (7) into the upper part of the spindle (16) and press this against the previously described pieces.

C - Enter the guide (13), the separator (15), the spring-press (14), the spring (22), the spring-press (14) through the upper part of the spindle (16) and press this against the previously described pieces.

D - Replace the assembly (38) and the cover (3) or (2).

E - Place the washers (30) on the studs (32) and make up the nuts (29) diagonally, checking the correct alignment of the cover (3) or (2).

F - Adjust the firing pressure with the hollow screw (24) and fix the adjustment position with the hollow screw nut (25).

G - Turn the spindle lock-nut (27) and the adjusting nut (26) to the position marked (see 1.1.D) and make up against each other.

H - Introduce the cap (6) and tighten the screws (34).

I - Place the lever (10) and fix it with the fastener (18).

### 2. Adjusting the firing pressure.

A - Proceed according to points 1.1.A, 1.1.B, 1.1.C.

B - Proceed according to points 1.2.F, 1.2.H, 1.2.I.

## Full lift safety valve with spring loading (AIT) model 486 - EP.

### 1. Disassembly and assembly .

#### 1.1 Disassembly.

To replace the spring (22), or clean any of the internal components of the valve, proceed in the following manner:

A - Move the lever (9) in direction C as far as the constructive catcher.

B - Unscrew the cap (4) and remove.

C - Holding the spindle (16) steady, loosen the hollow screw nut (25) and the hollow screw (24) until you note a releasing of the spring (22).

D - Mark on the spindle (16) the position of the spindle lock-nut (27) and the adjusting nut (26). Loosen them and remove them.

E - Unscrew the nuts (29) and remove them, together with the studs (32) and their washers (30).

F - Lift the cover (2) and you will have access to all of the components.

#### 1.2 Assembly.

A - Place the safety-ring (20) on the spindle (16) and press it against the gasket (12).

B - In the spindle channel (16) connect the ring (19) and fix it to the security-ring (21). Introduce the elevator (7) into the upper part of the spindle (16) and press this against the previously described pieces.

C - Enter the guide (13), the separator (15), the spring-press (14), the spring (22), the spring-press (14) through the upper part of the spindle (16) in a correlative manner.

D - Replace the assembly (38) and the cover (2).

E - Place the washers (30) on the studs (32) and make up the nuts (29) diagonally, checking the correct alignment of the cover (2).

F - Adjust the firing pressure with the hollow screw (24) and fix the adjustment position with the hollow screw nut (25).

G - Turn the spindle lock-nut (27) and the adjusting nut (26) to the position marked (see 1.1.D) and make up against each other.

H - Change the coupling (39) and lightly tighten the cap (4). Move the lever (9) towards position A as far as the constructive catcher. Definitely tighten the cap (4).

### 2. Adjustig the firing pressure.

A - Proceed according to points 1.1.A, 1.1.B, 1.1.C.

B - Proceed according to points 1.2.F, 1.2.H.

## Full lift safety valve with spring loading (AIT) model 486 - ES.

### 1. Disassembly and assembly.

#### 1.1 Disassembly.

To replace the spring (22), or clean any of the internal components of the valve, proceed in the following manner:

A - Unscrew the cap (5) and remove.

B - Holding the spindle (16) steady, loosen the hollow screw nut (25) and the hollow screw (24) until you note a releasing of the spring (22).

C - Unscrew the nuts (29) and remove them, together with the studs (32) and their washers (30).

F - Lift the cover (2) and you will have access to all of the components.

#### 1.2 Assembly.

A - Place the safety-ring (20) on the spindle (16) and press it against the gasket (12).

B - In the spindle channel (16) connect the ring (19) and fix it to the security-ring (21).

Introduce the elevator (7) into the upper part of the spindle (16) and press this against the previously described pieces.

C - Enter the guide (13), the separator (15), the spring-press (14), the spring (22), the spring-press (14) through the upper part of the spindle (16) in a correlative manner.

D - Replace the washers (38) and the cover (2).

E - Place the washers (30) on the studs (32) and make up the nuts (29) diagonally, checking the correct alignment of the cover (2).

F - Adjust the firing pressure with the hollow screw (24) and fix the adjustment position with the hollow screw nut (25).

G - Change the coupling (39) and tighten the cap (5).

### 2. Adjusting the firing pressure.

A - Proceed according to points 1.1.A, 1.1.B.

B - Proceed according to points 1.2.F, 1.2.G.

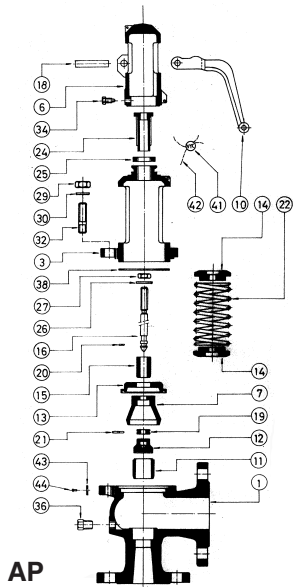

AP

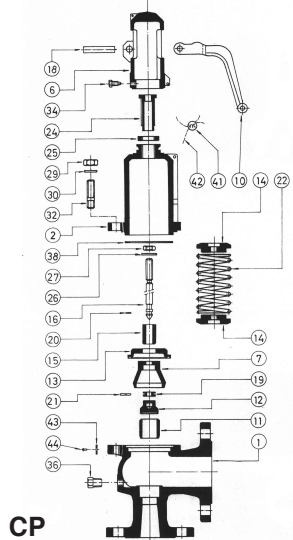

CP

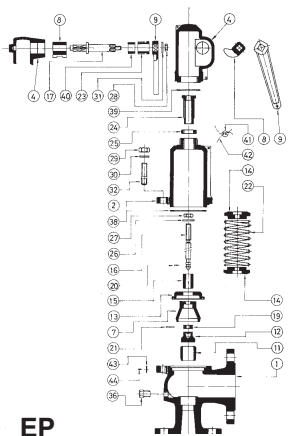

EP

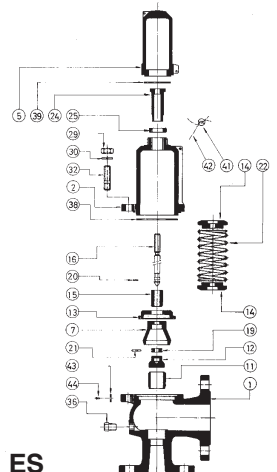

ES



## SET PRESSURES AND REGULATING RANGES

NPS <sub>1</sub> x NPS <sub>2</sub>		1"x 2"	1 1/2" x 2"	1 1/2" x 2 1/2"	1 1/2" x 3" (2"x3")	2"x 3" (3"x4")	3"x 4" (4"x6")	4"x 6"	4"x 6"	6"x 8"	8"x10"	
API Orifice Letter		D-E	F	G	H	J	L	N	P	Q	T	
SET PRESSURES IN psi	MAXIMUM (LIQUIDS AND GASES)	150 lbs	284,27	284,27	284,27	284,27	284,27	284,27	284,27	284,27	145,04	116,03
		300 lbs	580,15	580,15	580,15	464,12	464,12	464,12	362,59	290,08	145,04	116,03
	MAXIMUM (SATURATED STEAM)	150 lbs	284,27	284,27	284,27	284,27	284,27	284,27	284,27	284,27	145,04	116,03
		300 lbs	580,15	580,15	580,15	464,12	464,12	464,12	362,59	290,08	145,04	116,03
	MINIMUM	STEAM AND GASES	7,25	7,25	7,25	7,25	7,25	7,25	7,25	7,25	7,25	7,25
LIQUIDS		2,90	2,90	2,90	2,90	2,90	2,90	2,90	2,90	2,90	2,90	
SPRING REGULATING RANGE IN psi	2,90 to 9,86	CODE	56210 56390	56226 56406	56242 56422	56258 56438	56273 56453	56288 56468	56303 56483	56317 56497	56511	56521
	9,57 to 14,50	CODE	56211 56391	56227 56407	56243 56423	56259 56439	56274 56454	56289 56469	56304 56484	56318	56512	56522
	13,78 to 20,31	CODE	56212 56392	56228 56408	56244 56424	56260 56440	56275 56455	56290 56470	56305 56485	56319	56513	56523
	18,85 to 27,56	CODE	56213 56393	56229 56409	56245 56425	56261 56441	56276 56456	56291 56471	56306 56486	56320	56514	56524
	26,11 to 37,71	CODE	56214 56394	56230 56410	56246 56426	56262 56442	56277 56457	56292 56472	56307	56321	56515	56525
	36,26 to 52,21	CODE	56215 56395	56231 56411	56247 56427	56263 56443	56278 56458	56293 56473	56308	56322	56516	56526
	50,76 to 72,52	CODE	56216 56396	56232 56412	56248 56428	56264 56444	56279 56459	56294	56309	56323	56517	56527
	69,62 to 91,37	CODE	56217 56397	56233 56413	56249 56429	56265 56445	56280 56460	56295	56310	56324	56518	56528
	87,02 to 116,03	CODE	56218 56398	56234 56414	56250 56430	56266 56446	56281 56461	56296	56311	56325	56519	56529
	108,78 to 145,04	CODE	56219 56399	56235 56415	56251 56431	56267 56447	56282 56462	56297	56312	56326	56520	
	137,79 to 181,30	CODE	56220 56400	56236 56416	56252 56432	56268 56448	56283	56298	56313	56327		
	174,05 to 232,06	CODE	56221 56401	56237 56417	56253 56433	56269 56449	56284	56299	56314	56328		
	217,56 to 290,08	CODE	56222 56402	56238 56418	56254 56434	56270	56285	56300	56315	56329		
	261,07 to 362,59	CODE	56223 56403	56239 56419	56255 56435	56271	56286	56301	56316			
	333,59 to 464,12	CODE	56224 56404	56240 56420	56256 56436	56272	56287	56302				
435,11 to 580,15	CODE	56225 56405	56241 56421	56257 56437								

- Spring steel (ASTM A228). Maximum temperature for EP, ES and CP 482°F / AP 752°F.
- Vanadium-chrome steel (AISI 6150).
- Stainless steel (AISI 301).

ASME code only applies to setted safety valves at ≥15 psi or above.

COEFFICIENT OF DISCHARGE											
NPS <sub>1</sub> x NPS <sub>2</sub>	1"x2"	1 1/2" x 2"	1 1/2" x 2 1/2"	1 1/2" x 3" (2"x3")	2"x3" (3"x4")	3"x4" (4"x6")	4"x6"	4"x6"	6"x8"	8"x10"	
API Orifice Letter	D-E	F	G	H	J	L	N	P	Q	T	
do	0,63	0,79	0,98	1,26	1,57	1,97	2,48	3,03	4,33	6,10	
h	0,28	0,35	0,47	0,47	0,71	0,71	0,79	1,14	1,45	2,21	
h1	0,10	0,13	0,16	0,20	0,26	0,31	0,39	0,49	0,78	1,10	
h/do	0,017	0,018	0,019	0,015	0,018	0,014	0,012	0,015	0,013	0,014	
h1/do (1)	0,006	0,006	0,006	0,006	0,006	0,006	0,006	0,006	0,007	0,007	
COEFFICIENT OF DISCHARGE kd	SATURATED STEAM GASES		0,78							0,74	
	LIQUIDS		0,60							0,52	
	LIQUIDS WITH RAPID LIMITER (1)		0,36								

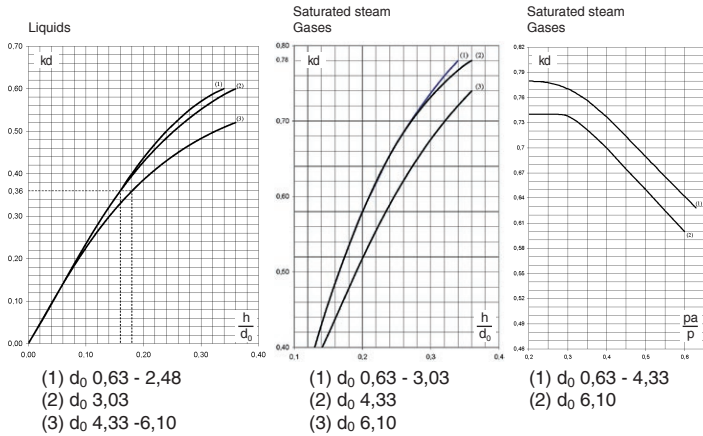
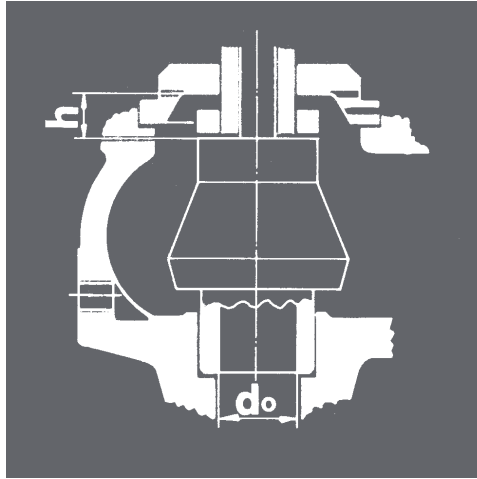

NPS <sub>1</sub> x NPS <sub>2</sub>	1"x2"	1 1/2" x 2"	1 1/2" x 2 1/2"						
API Orifice Letter	D-E	F	G						
do	0,63	0,79	0,98						
$A_0 = \frac{\pi \cdot d_0^2}{4}$	0,31	0,49	0,76						
P [psi]	I - Saturated steam in lb/h.								
	II - Air at 60°F and 14,50 psi in [S.C.F.M.]								
SET PRESSURE IN psi	III - Water at 70°F in US - G.P.M..								
	I	II	III	I	II	III	I	II	III
15,00	401	143	40	626	223	63	978	348	98
21,76	491	175	45	768	273	70	1200	427	109
29,01	582	207	48	910	324	76	1421	506	118
36,26	681	242	52	1064	378	82	1662	591	128
43,51	781	278	56	1220	434	88	1906	678	137
50,76	880	313	60	1376	489	93	2149	765	145
58,02	980	349	63	1532	545	98	2393	851	154
65,27	1080	384	66	1688	600	103	2637	938	161
72,52	1180	420	69	1844	656	108	2881	1025	168
87,02	1380	491	75	2156	767	117	3368	1198	182
101,53	1579	562	80	2468	878	125	3856	1372	195
116,03	1779	633	85	2780	989	132	4343	1545	207
130,53	1979	704	89	3092	1100	140	4831	1719	218
145,04	2178	775	94	3404	1211	146	5318	1892	229
174,05	2578	917	102	4028	1433	159	6293	2239	249
203,05	2977	1059	110	4652	1655	171	7268	2586	268
232,06	3376	1201	117	5276	1877	182	8243	2933	285
261,07	3776	1343	123	5900	2099	193	9218	3279	301
290,08	4175	1485	130	6524	2321	203	10193	3626	317
319,08	4574	1627	136	7147	2543	212	11168	3973	332
348,09	4974	1769	142	7771	2765	221	12143	4320	346
377,10	5373	1912	147	8395	2987	230	13118	4667	359
406,11	5772	2054	153	9019	3209	238	14093	5014	373
435,11	6172	2196	158	9643	3431	247	15068	5361	385
464,12	6571	2338	163	10267	3653	254	16043	5707	397
493,13		2480	168		3875	262		6054	409
522,14		2622	172		4097	269		6401	421
551,14		2764	177		4319	277		6748	432
580,15		2906	182		4541	284		7095	443

Calculated discharge capacities at set pressure +10% overpressure.

Discharge capacities at 30 psi and below are calculated at set pressure + 3 psi of overpressure.



**FACT LIST FOR SAFETY VALVE CALCULS**  
Calculus according to ASME code section VIII Div.1

Customer:  
Theme:  
Leaf: \_\_\_\_\_ Of: \_\_\_\_\_

1	Consultation / Bid / Order					
2	Position N°.					
3	N°. of units					
4	Regulation					
5	SERVICE CONDITIONS	Fluid				
6		Calculation temperature °F				
7		State at moment of dischar. l = liquid, s = steam, g = gas		l <input type="checkbox"/> s <input type="checkbox"/> g <input type="checkbox"/>	l <input type="checkbox"/> s <input type="checkbox"/> g <input type="checkbox"/>	l <input type="checkbox"/> s <input type="checkbox"/> g <input type="checkbox"/>
8		Molecular mass lb/lbmol				
9		Adiabatic exponent æ	Compressibility coe. Z			
10		Density at moment of discharge lb/in³				
11		Coefficients ψ max	χ			
12		Viscosity in²/s	lbf s/in²			
13		Working pressure abs. psi				
14		Set pressure abs. psi				
15		External back pressure abs.				
			constant	variable	psi	
16		Rated pressure abs. psi				
17		Discharge capacity	Required: lb/h, [S.C.F.M.], US - G.P.M			
18		Possible: 1) lb/h, [S.C.F.M.], US - G.P.M				
19	VALVE CONSTRUCTION	Opening: Full lift / Normal / Progressive				
20		Manufacturer type				
21		Materials	Body			
22			Seat			
23			Plug			
24			Spring			
25			Joint			
26		Manual discharge action		yes / no		
27		Cover		Closed / Open		
28		Bellows		yes / no		
29		Body with drainage		yes / no		
30		Diameter of narrowest flow d <sub>0</sub>		inch		
31		Section of narrowest flow A <sub>0</sub>	Necessary A <sub>0</sub>		inch²	
32			Chosen A <sub>0</sub>		inch²	
33	Allowed discharge coefficient		kd			
34	CONNECTIONS	Input / Output	NPS	Flange	inch	
35				Thread	inch NPT	
36				Welding (soldering) ends		
37			Class			
38		Shape of joint surfaces (ASME/ANSI B16.5-2009)				
39	OBSERVATIONS	Unit weight		approx. lb		
40						
41						
42						
43	ACCEPTANCE	Certificate according to		EN-10204 2.2		
44		Certificate according to		EN-10204 3.2		
45						

Date: \_\_\_\_\_  
Department: \_\_\_\_\_  
Name: \_\_\_\_\_