

Machining Tolerances	
Dimension	Tolerance
0.5-3	±0.1
>3-6	±0.1
>6-30	±0.1
>30-120	±0.3
>120-400	±0.5

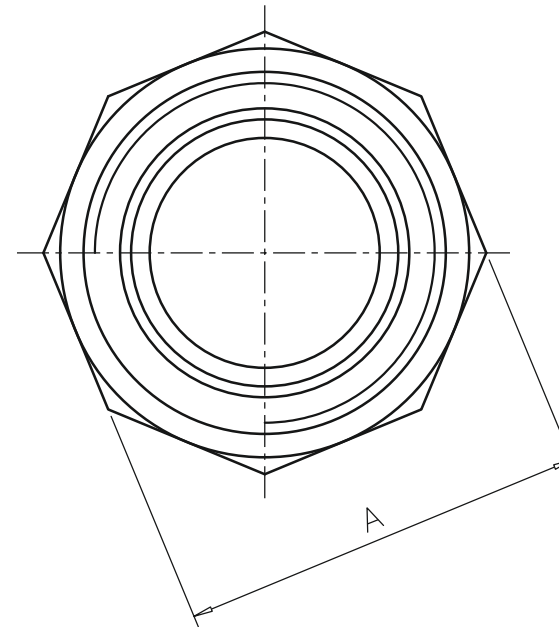
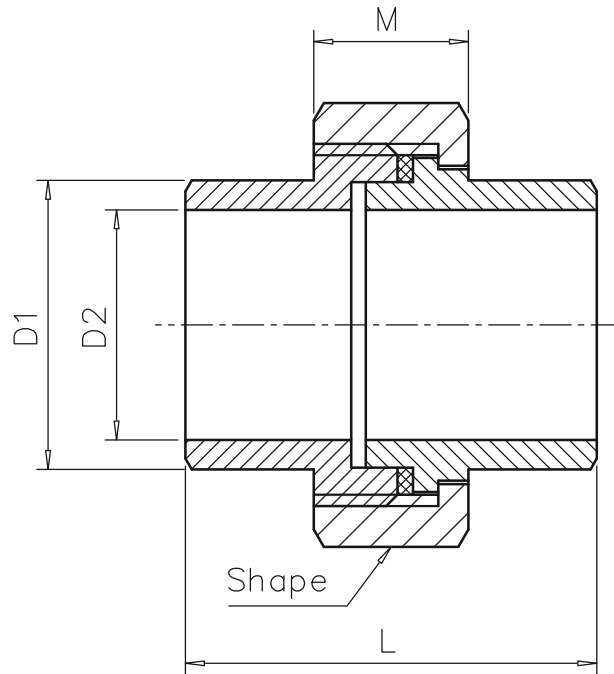

unit: mm

Size	1/8"	1/4"	3/8"	1/2"	3/4"	1"	1-1/4"	1-1/2"	2"	2-1/2"	3"	4"
D1	13	13.7	17.2	21.3	26.7	33.4	42.2	48.3	60.3	76.1	88.9	114.3
D2	8.2	9.2	12.5	15.8	20.9	26.6	35	40.9	52.5	65.8	77.9	102.3
A	26	29	34	37	44	52.5	63	70	84	101.5	118	148.5
L	30	33.5	36.5	39.5	42.5	50	54	58	65	75	83	110
M	13	13.5	15	16	17	20	22	24	27	29.5	31	34

Shape: 1/4"-2" Octagon
 2-1/2"-4" Decagon



Butt Welding
 Union Flat Sealing

304/316

Rev: 6.22.2018