

Machining Tolerances	
Dimension	Tolerance
0.5–3	±0.1
>3–6	±0.1
>6–30	±0.1
>30–120	±0.3
>120–400	±0.5

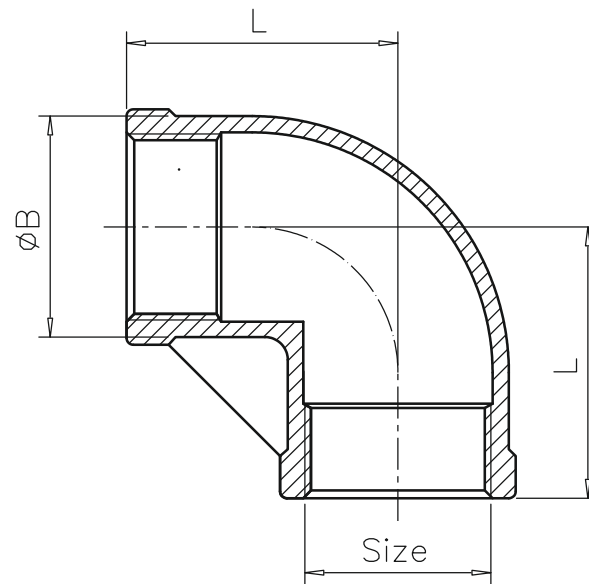

unit: mm

Size	1/8"	1/4"	3/8"	1/2"	3/4"	1"	1-1/4"	1-1/2"	2"	2-1/2"	3"	4"
B	13	16.5	20	24.5	30	37.5	46.5	53	65.5	82	95.5	121.5
L	17	19	23	27	32	38	45	48	57	69	78	96

According to ISO 4144 Fig.2 E1



Elbow 90°

304/316

Rev: 6.22.2018