

Machining Tolerances	
Dimension	Tolerance
0.5–3	±0.1
>3–6	±0.1
>6–30	±0.1
>30–120	±0.3
>120–400	±0.5

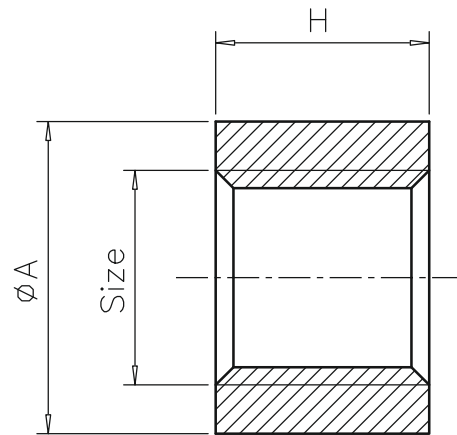

unit: mm

Size	1/8"	1/4"	3/8"	1/2"	3/4"	1"	1-1/4"	1-1/2"	2"	2-1/2"	3"	4"
A	14	18.5	21.3	26.4	31.8	39.5	48.3	54.5	66.3	82	95	122
H	8	11	12	15	17	20	22	22	26	30	34	40

According to DIN 2986



Half Socket

304/316

Rev: 6.22.2018