

Machining Tolerances

Dimension	Tolerance
0.5–3	±0.1
>3–6	±0.1
>6–30	±0.1
>30–120	±0.3
>120–400	±0.5

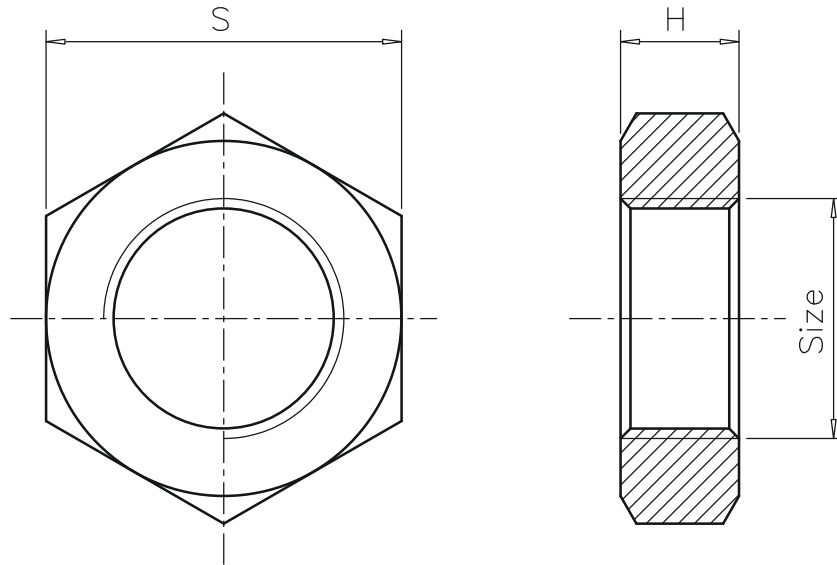

unit: mm

Size	1/8"	1/4"	3/8"	1/2"	3/4"	1"	1-1/4"	1-1/2"	2"	2-1/2"	3"	4"
H	5	6	6	7	7	9	11	11	13	15	17	19
S	16	18	24	30	34	42.5	52	58	72	85	100	125



Nut

304/316

Rev: 6.22.2018