

| Machining Tolerances | |
|----------------------|-----------|
| Dimension | Tolerance |
| 0.5–3 | ±0.1 |
| >3–6 | ±0.1 |
| >6–30 | ±0.1 |
| >30–120 | ±0.3 |
| >120–400 | ±0.5 |

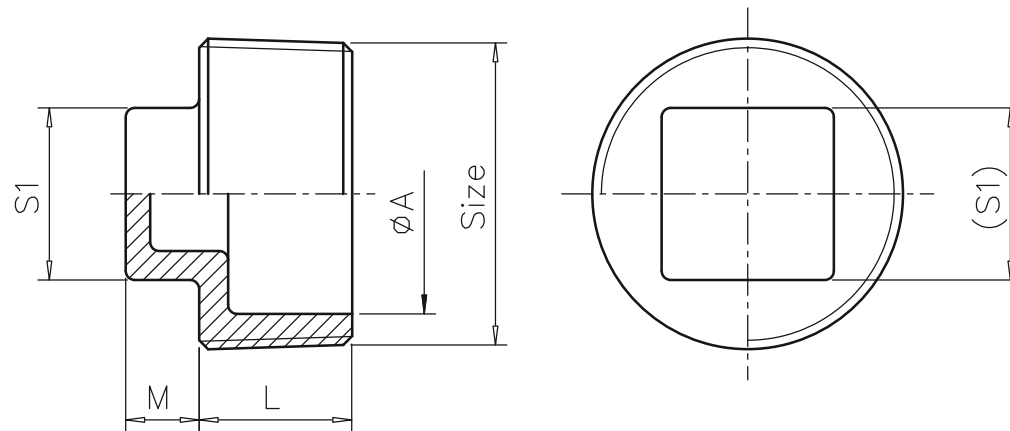

unit: mm

| Size | 1/8" | 1/4" | 3/8" | 1/2" | 3/4" | 1" | 1-1/4" | 1-1/2" | 2" | 2-1/2" | 3" | 4" |
|------|------|------|------|------|------|------|--------|--------|------|--------|------|-------|
| L | 6 | 8.5 | 9 | 11.5 | 13 | 14.5 | 17 | 17 | 21.5 | 23.5 | 26.5 | 32.5 |
| S1 | 7 | 9 | 10 | 11 | 15 | 18 | 20.5 | 22 | 28 | 32 | 36 | 42 |
| A | 5.5 | 8 | 11.5 | 15 | 20.5 | 26.2 | 34.5 | 40 | 51 | 65.5 | 77.5 | 101.5 |
| M | 5 | 5 | 6 | 7 | 8 | 11 | 11 | 12 | 13 | 15 | 15 | 19 |

According to ISO 4144 Fig.13 P1



Square Plug

304/316

Rev: 6.22.2018