

Machining Tolerances	
Dimension	Tolerance
0.5–3	±0.1
>3–6	±0.1
>6–30	±0.1
>30–120	±0.3
>120–400	±0.5

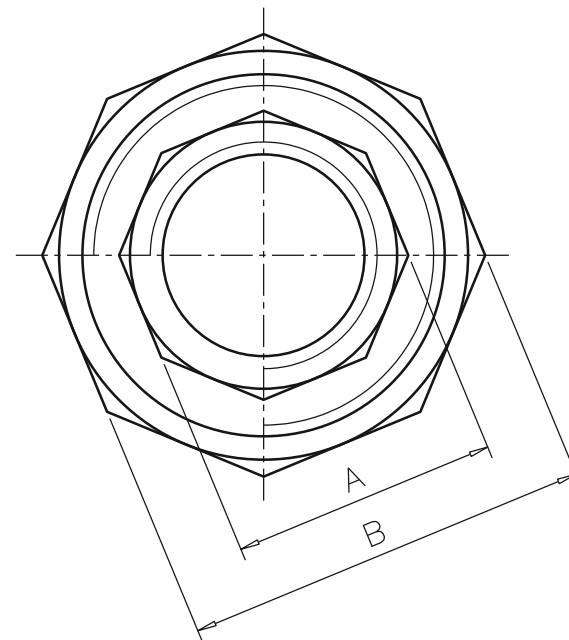
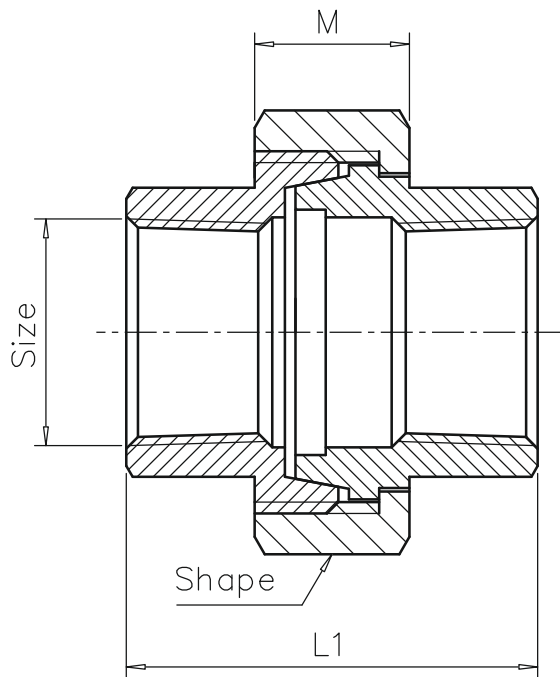

unit: mm

Size	1/8"	1/4"	3/8"	1/2"	3/4"	1"	1-1/4"	1-1/2"	2"	2-1/2"	3"	4"
A	13	16.5	20	24.5	30	37	46.5	53	65	82	95.5	121.5
B	26	29	34	37	44	52.5	63	70	84	101.5	118	148.5
L1	30	33.5	36.5	39.5	42.5	50	54	58	65	75	83	110
M	13	13.5	15	16	17	20	22	24	27	29.5	31	34

According to ISO 4144 Fig.14 U4

Shape: 1/8"–1/2"  
 3/4"–2"  
 2-1/2"–4"

Hexagon  
 Octagon  
 Decagon



Union FF Conical Sealing

304/316

Rev: 6.22.2018