

| Machining Tolerances |           |
|----------------------|-----------|
| Dimension            | Tolerance |
| 0.5–3                | ±0.1      |
| >3–6                 | ±0.1      |
| >6–30                | ±0.1      |
| >30–120              | ±0.3      |
| >120–400             | ±0.5      |

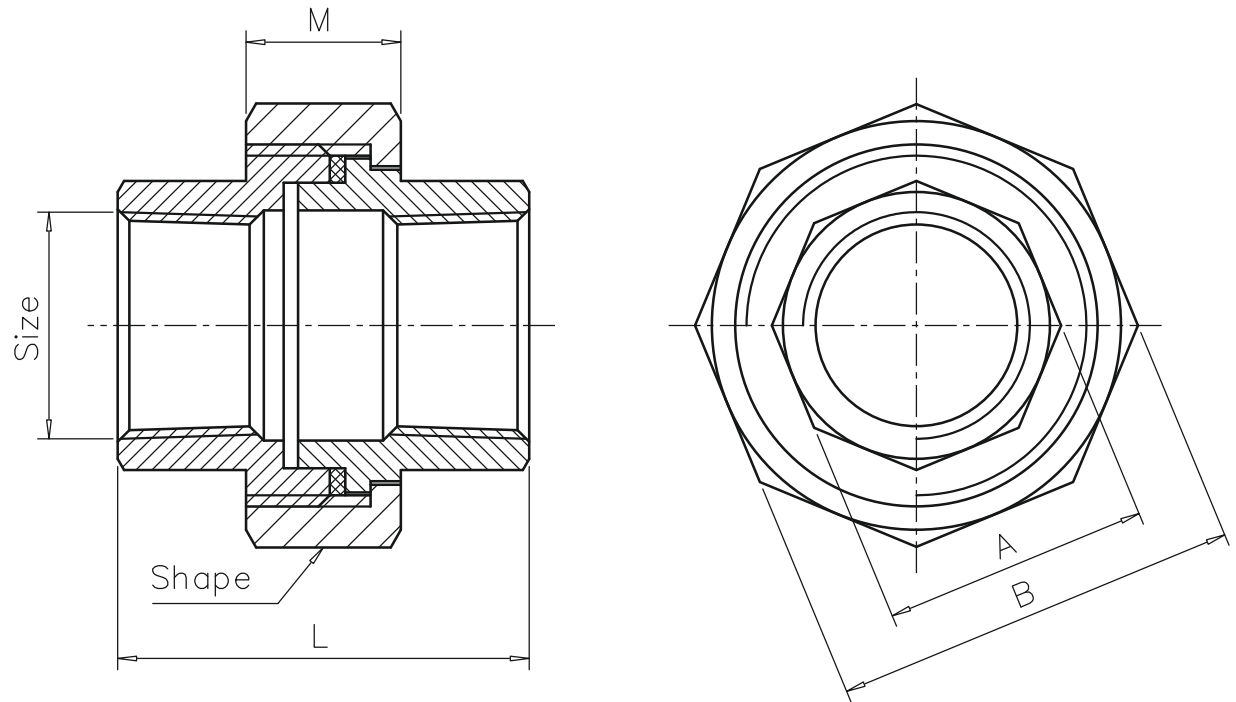

unit: mm

| Size | 1/8" | 1/4" | 3/8" | 1/2" | 3/4" | 1"   | 1-1/4" | 1-1/2" | 2" | 2-1/2" | 3"   | 4"    |
|------|------|------|------|------|------|------|--------|--------|----|--------|------|-------|
| A    | 13   | 16.5 | 20   | 24.5 | 30   | 37   | 46.5   | 53     | 65 | 82     | 95.5 | 121.5 |
| B    | 26   | 29   | 34   | 37   | 44   | 52.5 | 63     | 70     | 84 | 101.5  | 118  | 148.5 |
| L1   | 30   | 33.5 | 36.5 | 39.5 | 42.5 | 50   | 54     | 58     | 65 | 75     | 83   | 110   |
| M    | 13   | 13.5 | 15   | 16   | 17   | 20   | 22     | 24     | 27 | 29.5   | 31   | 34    |

According to ISO 4144 Fig.14 U1

Shape: 1/8"–1/2"      Hexagon  
 3/4"–2"            Octagon  
 2-1/2"–4"          Decagon

|  |                       |                |
|--|-----------------------|----------------|
|  <p><b>Alfacom</b><br/>         אלפא קום אספקה הונדסית בע"מ<br/>         Industrial Automation Products<br/>         www.alfacom.co.il<br/>         e-mail: info@alfacom.co.il</p> | Union FF Flat Sealing | 304/316        |
|  |                       | Rev: 6.22.2018 |