

# XF Series

## Cast Version

### Technical Datasheet



**XF SERIES**  
CL600 (1500 psi)  
FULL BORE - DN 10 (3/8") ÷ 40 (1 1/2")  
REDUCED BORE - DN 15 (1/2") ÷ 50 (2")  
**STANDARD**  
**BILL OF MATERIALS**

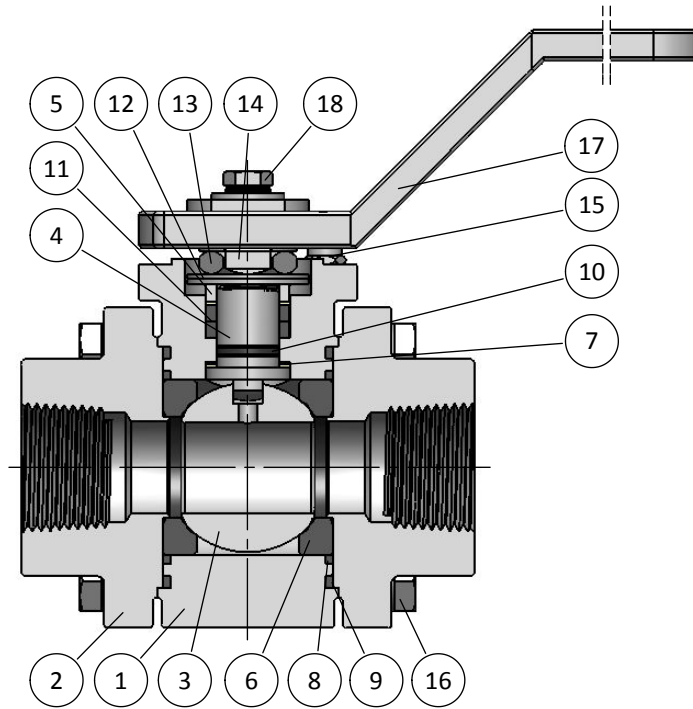
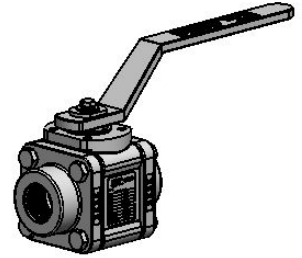

**BILL OF MATERIALS**

Part	Qt.	Description	CARBON STEEL VERSION	STAINLESS STEEL VERSION
1	1	Body	A216 WCB	A351 CF3M
2	2	End	A216 WCB	A351 CF3M
3	1	Ball	A351 CF8M	
4	1	Stem	A479 316-316L	
5	1	Gland Packing	A479 316-316L	
6	2	Seat	CG-RPTFE	
7	1	Stem Thrust Seals	CG-RPTFE + PEEK	
8	2	1st Body Seal	CG-RPTFE	
9	2	2nd Body Seal	GRAPHITE	
10	1	O'Ring	FKM	
11	1	Stem Packing Set	GRAPHITE + PEEK	
12	2	Disc Spring	STAINLESS ST. 316	
13	1	Stem Nut	STAINLESS ST. 316	
14	1	Locking Clip	STAINLESS ST. 316	
15	1	Stop Pin	STAINLESS ST. 316	
16	8	Bolt	A193 B7	A193 B8M cl.2
17	1	Handle	A351 CF8M	
18	1	Handle Fastener	STAINLESS ST. 304	

↳ TYPICAL SPARE PARTS

## XF SERIES

CL600 (1500 psi)  
 FULL BORE - DN 10 (3/8") ÷ 40 (1 1/2")  
 REDUCED BORE - DN 15 (1/2") ÷ 50 (2")  
 THREADED & WELDED ENDS

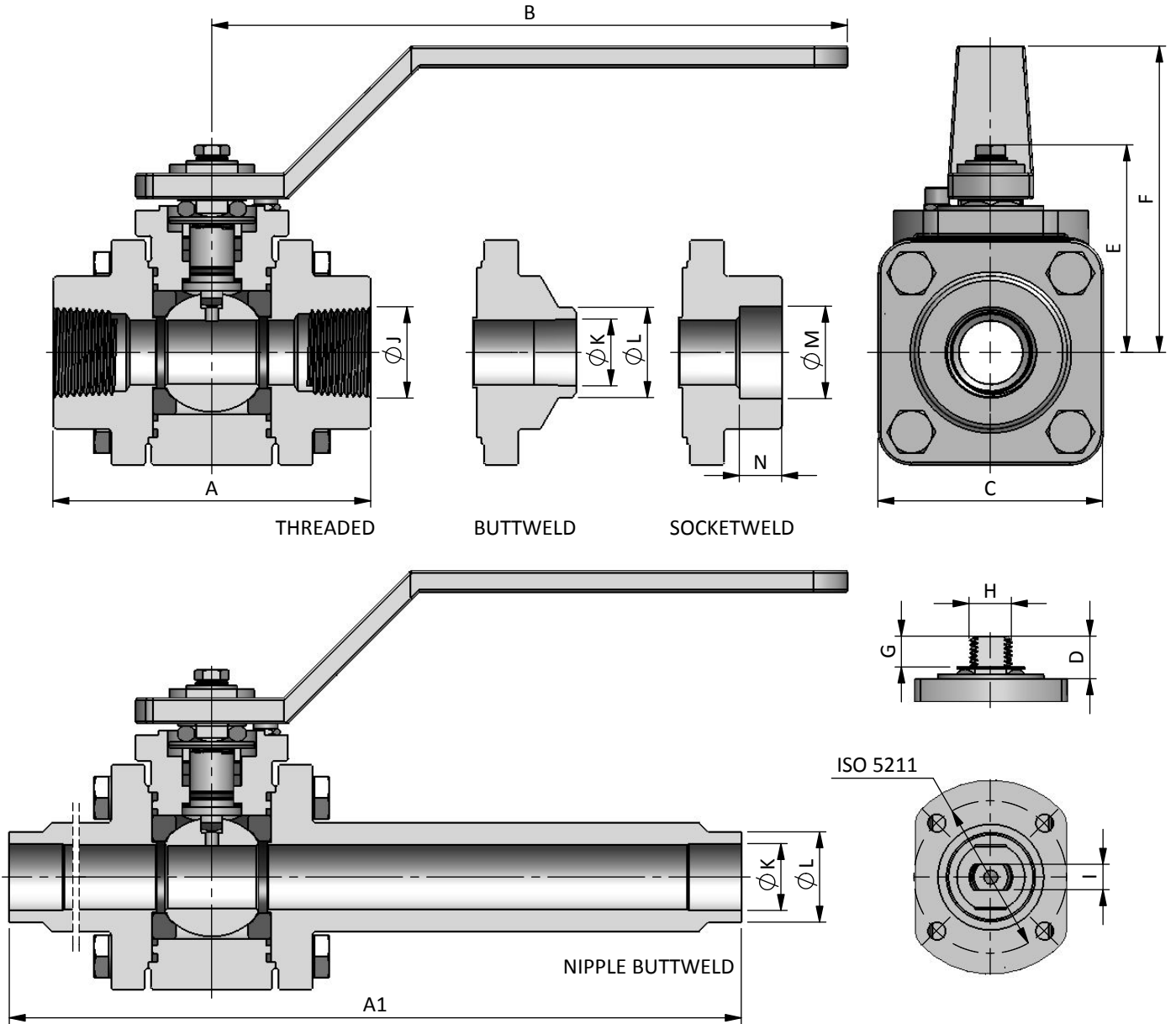
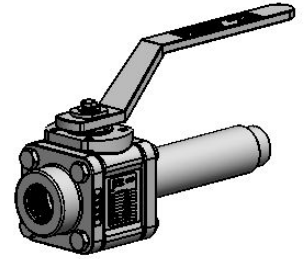

DN / Size				Dimensions							Automation				Weight Approx. [kg]		
FULL BORE		REDUCED BORE		Ball Port	A	A1	B	C	D	E	F	G	H	I	ISO 5211	Short	Long
mm	inch	mm	inch														
10	3/8"	15	1/2"	11.9	70	-	150	48	10	47.5	70.5	6	10	6	F03	1	-
15	1/2"	20	3/4"	15.1	75	250	150	53	10	50	73.5	6	10	6	F03	1.2	1.6
20	3/4"	25	1"	20.7	90	260	180	64.5	16.5	62.5	90	9.5	12	7.5	F04	2	2.5
25	1"	32	1 1/4"	25.4	100	270	180	72	16.5	66	95	9.5	12	7.5	F04	3	3.5
32	1 1/4"	40	1 1/2"	31.8	115	280	230	86	21.5	82.5	115	11.5	16	11	F05	4.5	6
40	1 1/2"	50	2"	38.1	125	290	230	96	22	88	120	11.5	16	11	F05	6	7

DN / Size		Connections					
mm	inch	J	K	L	M	N	
10	3/8"	NPT	-	-	17.6	10	
15	1/2"				21.8	10	
20	3/4"				27.2	13	
25	1"	BSPT	-	-	33.9	13	
32	1 1/4"	BSP	-	-	42.7	13	
40	1 1/2"				48.8	13	
50	2"				61.2	17	

Nipple butt weld only available in full bore version

**XF SERIES**  
CL600/400/300 (1500/1000/750 psi)  
FULL BORE - DN 50 (2") ÷ 100 (4")  
STANDARD  
BILL OF MATERIALS

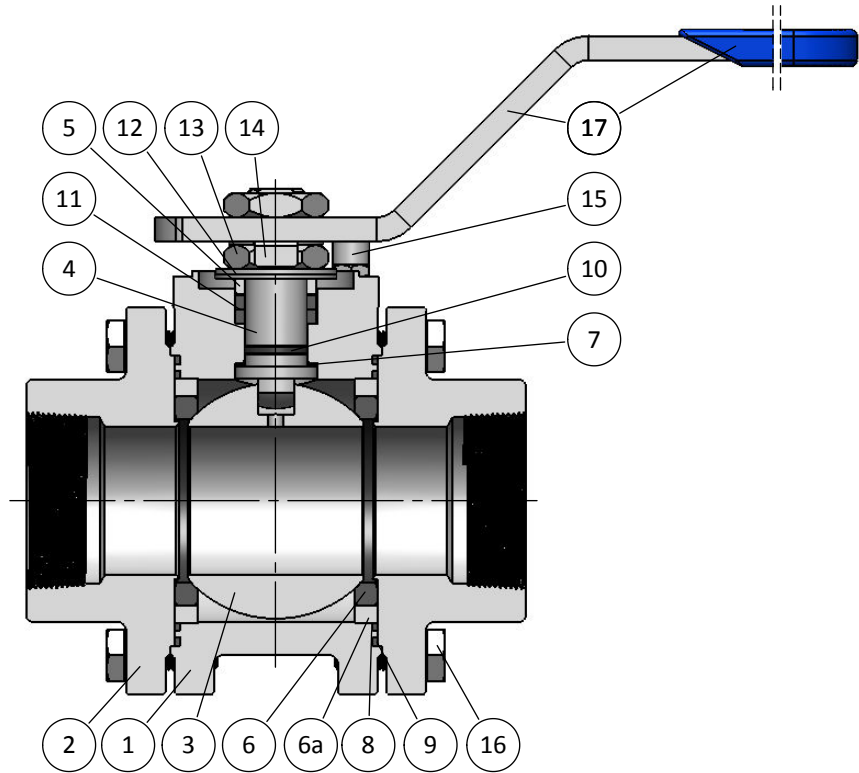
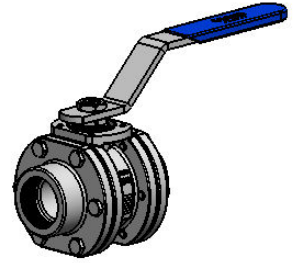

**BILL OF MATERIALS**

Part	Qt.	Description	CARBON STEEL VERSION	STAINLESS STEEL VERSION
1	1	Body	A216 WCB	A351 CF3M
2	2	End	A216 WCB	A351 CF3M
3	1	Ball	A351 CF8M	
4	1	Stem	A479 316-316L	
5	1	Gland Packing	A479 316-316L	
6	2	Seat	↘	CG-RPTFE
6a	2	Seat Support	A479 316-316L	
7	1	Stem Thrust Seals	↘	CG-RPTFE + PEEK
8	2	1st Body Seal	↘	CG-RPTFE
9	2	2nd Body Seal	↘	GRAPHITE
10	1	O'Ring	↘	FKM
11	1	Stem Packing Set	↘	GRAPHITE + PEEK
12	1/2	Disc Spring	STAINLESS ST. 316	
13	2	Stem Nut	STAINLESS ST. 316	
14	1	Locking Clip	STAINLESS ST. 316	
15	1	Stop Pin	STAINLESS ST. 304	
16	-	Bolt	A193 B7	A193 B8M cl.2
17	1	Handle	CARBON ST. ZINC. / VINYL	

↘ TYPICAL SPARE PARTS

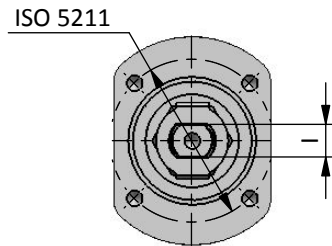
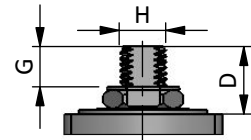
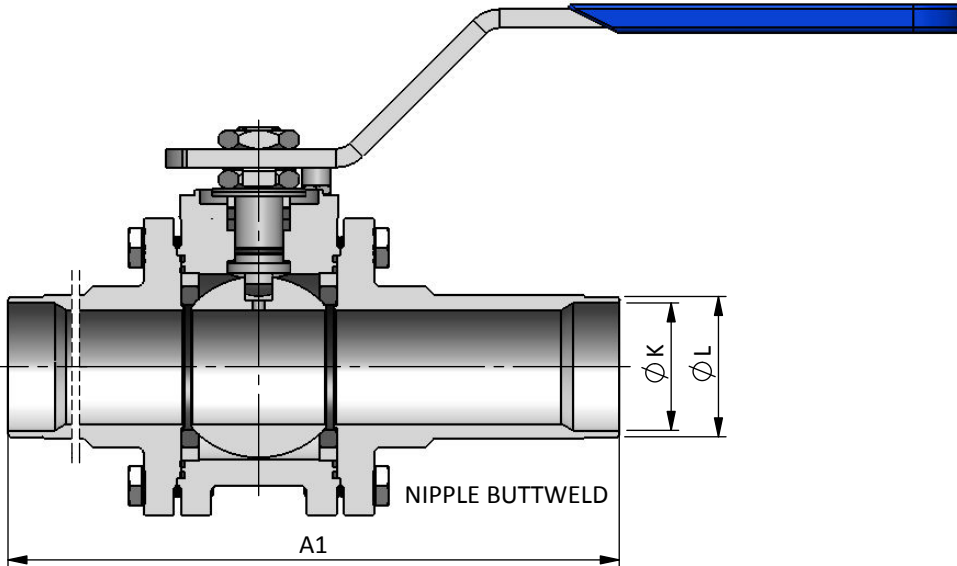
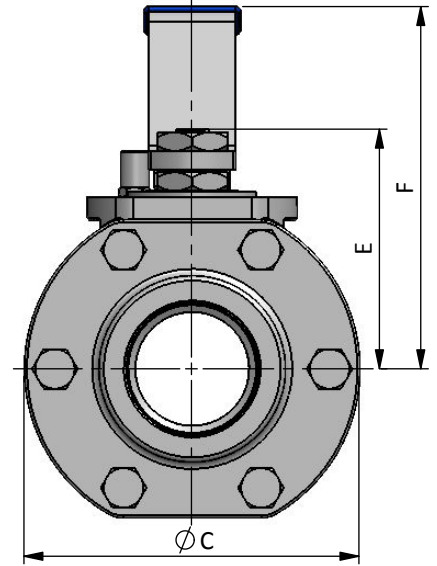
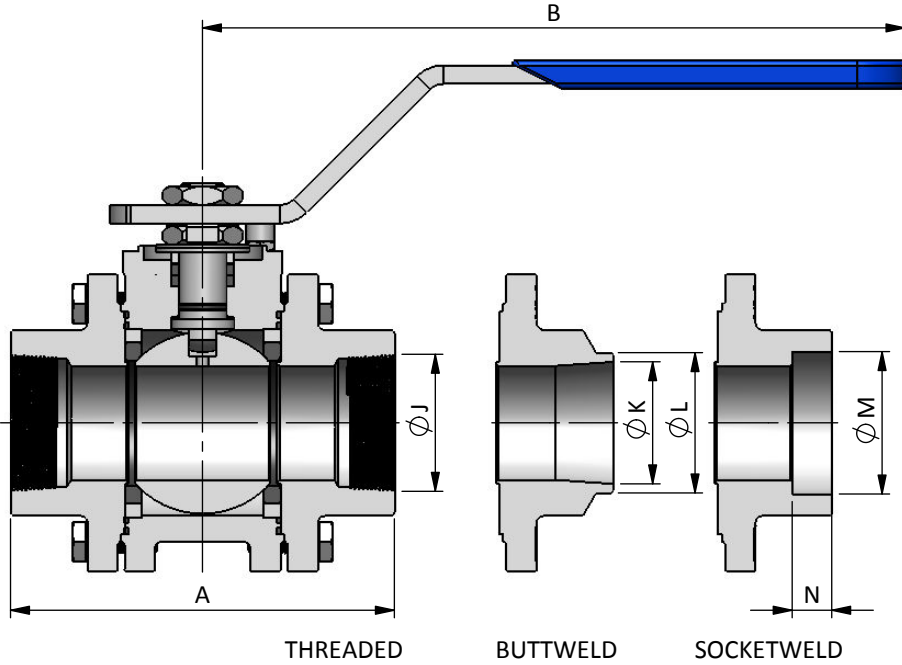
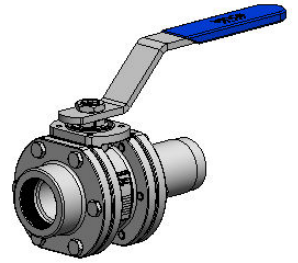

DN / Size		Dimensions								Automation				Weight Approx. [kg]	
FULL BORE		Ball Port	A	A1	B	C	D	E	F	G	H	I	ISO 5211	Short	Long
mm	inch														
50	2"	49	165	310	350	144	29	105	155	17	20	14	F07	10.5	11.5
65	2½"	62	190	330	350	174	41	135	185	25	24	18	F07	17.5	19.0
80	3"	75	215	350	350	194	36	145	200	23	24	18	F10	25.5	26.5
100	4"	100	265	390	500	244	50	185	235	28.5	30	22	F10	45.0	47.0

DN / Size		Connections				
mm	inch	J	K	L	M	N
50	2"	NPT - BSPT - BSP	BW ASME - BW ISO		61.2	17
65	2½"				74.4	17
80	3"				90.3	17
100	4"				115.7	20

**XF SERIES**

CL600/400/300 (1500/1000/750 psi)  
 FULL BORE - DN 10 (3/8") ÷ 100 (4")  
 REDUCED BORE - DN 15 (1/2") ÷ 50 (2")  
**LOCKING DEVICE VERSION**

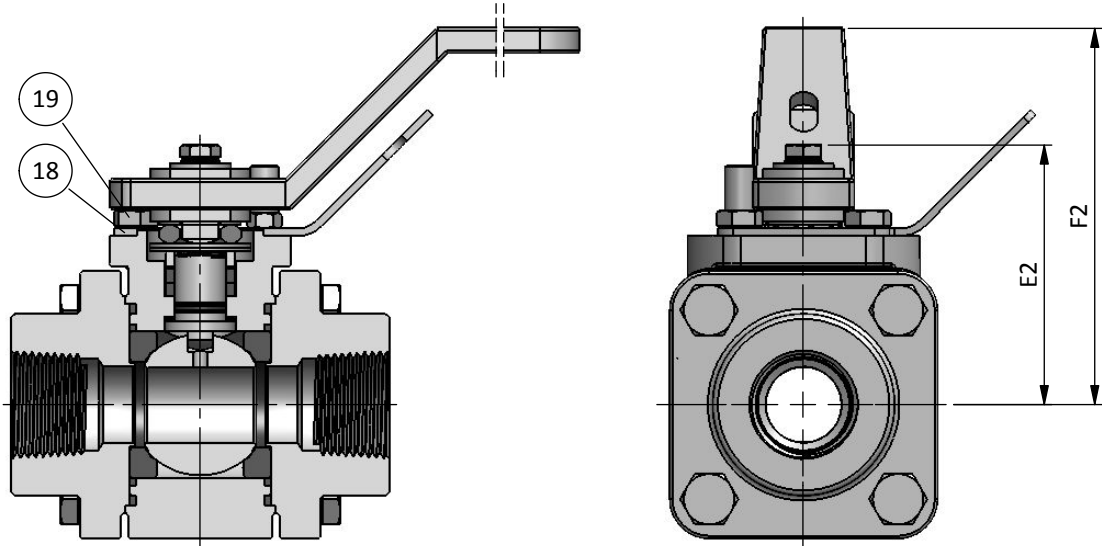
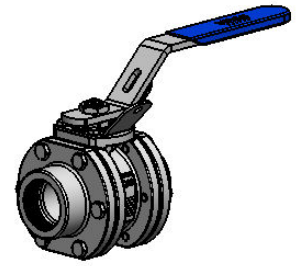

**BILL OF MATERIALS**

Part	Qt.	Description	Material
18	1	Locking Plate	CARBON ST. ZINC.
19	3	Bolt	STAINLESS ST. 304

DN / Size				E2	F2
FULL BORE		REDUCED BORE			
mm	inch	mm	inch		
10	3/8"	15	1/2"	49.5	72.5
15	1/2"	20	3/4"	52	75.5
20	3/4"	25	1"	62.5	90
25	1"	32	1 1/4"	66	95
32	1 1/4"	40	1 1/2"	82.5	115
40	1 1/2"	50	2"	88	120
50	2"	N/A		105	155
65	2 1/2"			135	185
80	3"			145	200
100	4"			185	235

**XF SERIES**

CL600/400/300 (1500/1000/750 psi)  
FULL BORE - DN 10 (3/8") ÷ 100 (4")  
REDUCED BORE - DN 15 (1/2") ÷ 50 (2")  
BRACKET FOR AUTOMATION VERSION

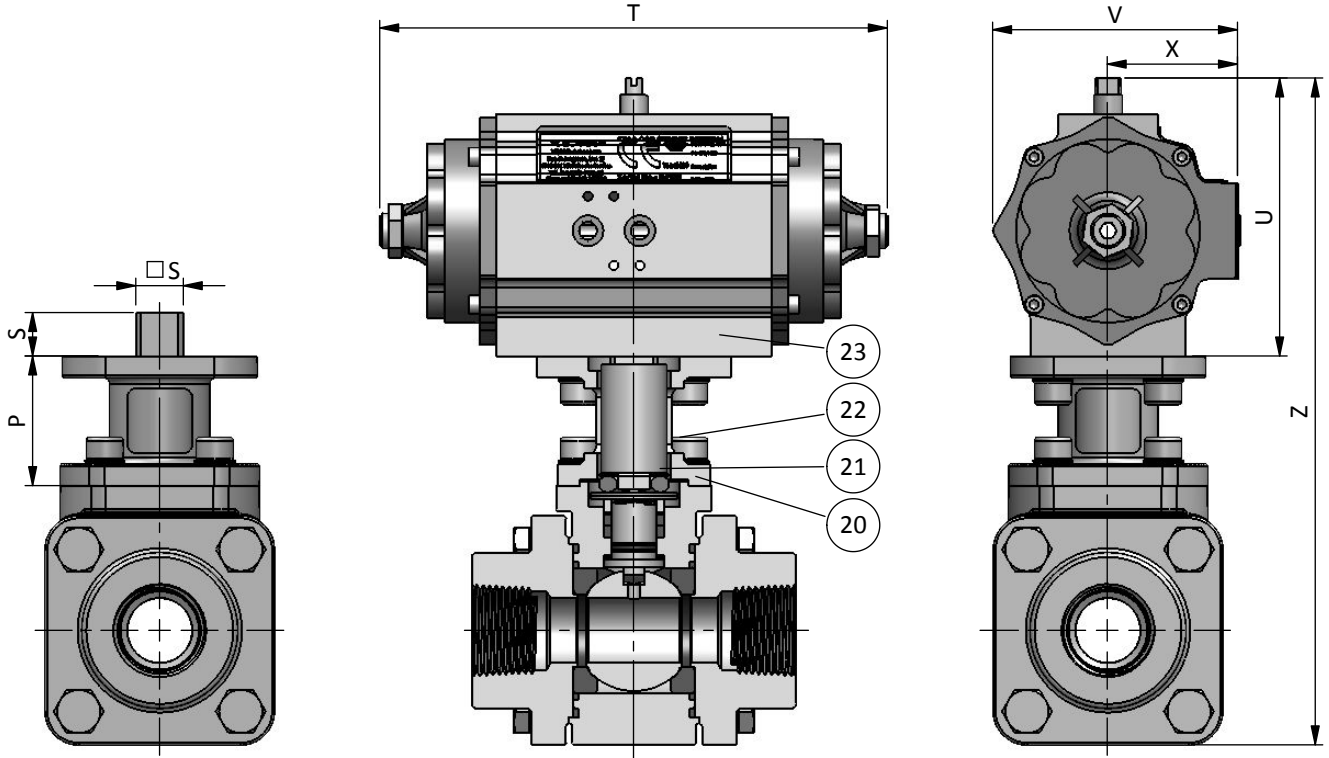
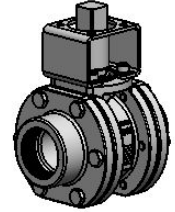

**BILL OF MATERIALS**

Part	Qt.	Description	Material
20	1	Bracket	A351 CF8M / STAINLESS ST. 304
21	1	Stem Extension	A479 316-316L
22	4	Bolt	STAINLESS ST. 304
23	1	Pneumatic Actuator	ALUMINIUM

DN / Size				Automation				Actuator #				
FULL BORE		REDUCED BORE		P	S	ISO 5211	REF.	T	U	V	X	Z
mm	inch	mm	inch									
10	3/8"	15	1/2"	30	9/11	F03/F04	005	180	111	89	49	205
15	1/2"	20	3/4"	30	9/11	F03/F04	005	180	111	89	49	210
20	3/4"	25	1"	35	11/14	F04/F05	008	233	131	112	57	245
25	1"	32	1 1/4"	35	11/14	F04/F05	008	233	131	112	57	250
32	1 1/4"	40	1 1/2"	45	14/17	F05/F07	012	280	131	112	57	280
40	1 1/2"	50	2"	45	14/17	F05/F07	020	294	151	133	70	310
50	2"	N/A		60	17/22	F07*	020	294	151	133	70	350
65	2 1/2"			60	17/22	F07*	030	286	189	169	85	415
80	3"			100	22/27	F10*	040	344	199	169	85	495
100	4"			100	22/27	F10*	040	344	199	169	85	540

\*Other options available

#Dimensions applicable for PTFE and filled PTFE seats

**XF SERIES**

CL600/400/300 (1500/1000/750 psi)  
 FULL BORE - DN 10 (3/8") ÷ 100 (4")  
 REDUCED BORE - DN 15 (1/2") ÷ 50 (2")  
**EXTENDED STEM VERSION**

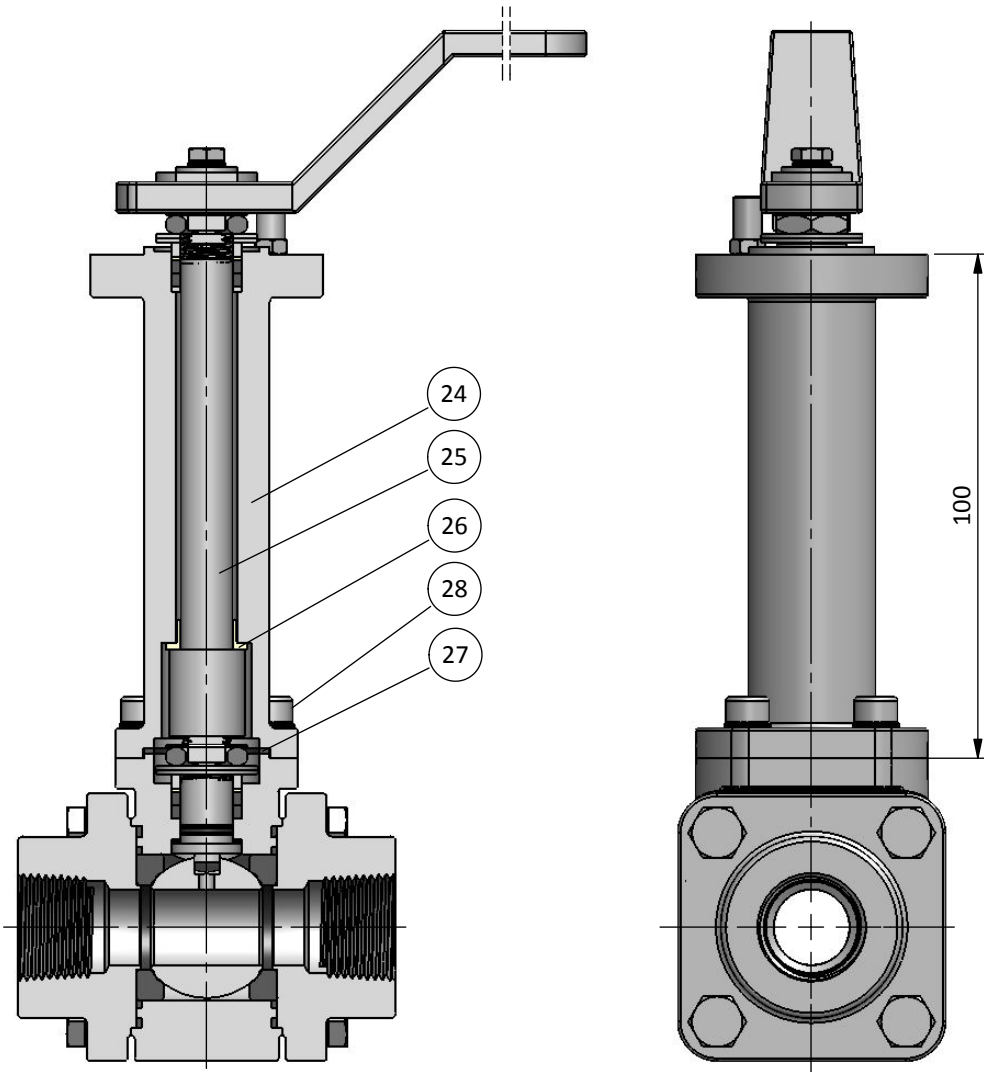
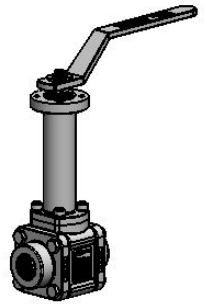

**BILL OF MATERIALS**

Part	Qt.	Description	CARBON STEEL VERSION	STAINLESS STEEL VERSION
24	1	Extension	A350 LF2 cl.1	A479 316-316L
25	1	Stem Extension	A479 316-316L	
26	1	Bearing	↘	PEEK
27	1	Extension Seal	↘	GRAPHITE
28	4	Bolt	STAINLESS ST. 304	



## XF SERIES

CL600/400/300 (1500/1000/750 psi)  
 FULL BORE - DN 10 (3/8") ÷ 100 (4")  
 REDUCED BORE - DN 15 (1/2") ÷ 50 (2")  
**TECHNICAL SPECIFICATIONS**

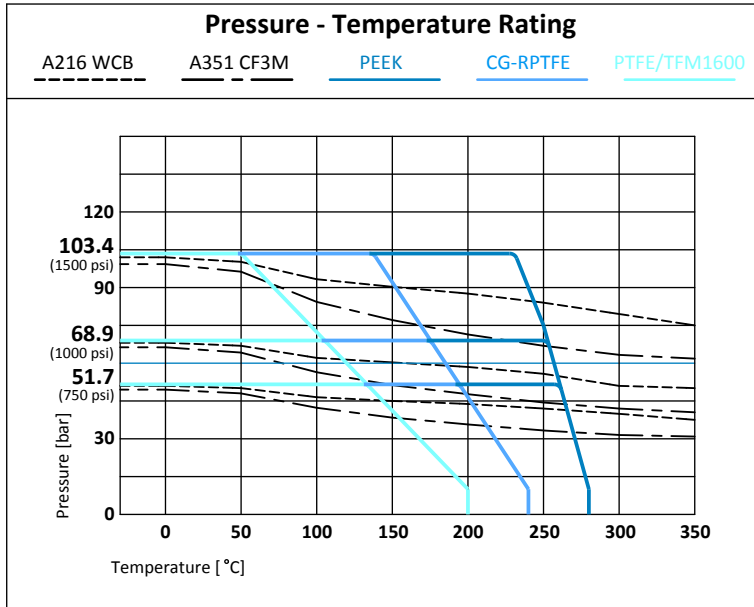

Seat Options		
Material	mOT* [°C]	MOT* [°C]
PTFE / TFM 1600	-196	200
CG-RPTFE	-196	240
PEEK	-40	280

\*mOT - minimum Operating Temperature.  
 Standard version recommended up to -46 °C  
 Extended version recommended up to -101 °C  
 \*MOT - Maximum Operating Temperature at 10 bar

DN	Rating
FB 10 (3/8") to 50 (2") RB 15 (1/2") to 50 (2")	103.4 bar / 1500 psi
FB 65 (2") to 80 (3")	68.9 bar / 1000 psi
FB 100 (4")	51.7 bar / 750 psi

DN / Size				Torque Valve Figure [Nm]						Maximum Allowable Stem Torque [Nm]					Flow Coefficient Cv
FULL BORE		REDUCED BORE		CG-RPTFE						316	F51	F55	17.4	718	
mm	inch	mm	inch	BTO	RTO	ETO	BTC	RTC	ETC	MAST					
10	3/8"	15	1/2"	6	4	4	4	3	5	16	25	30	40	53.5	8
15	1/2"	20	3/4"	8	5	6	6	4	7	16	25	30	40	53.5	13
20	3/4"	25	1"	12	8	8	8	7	10	29.5	45	55	71.5	98.5	27
25	1"	32	1 1/4"	18	12	13	13	10	15	29.5	45	55	71.5	98.5	41
32	1 1/4"	40	1 1/2"	30	20	21	21	17	26	82.5	125	150	200	275	77
40	1 1/2"	50	2"	39	25	27	27	21	33	82.5	125	150	200	275	96
50	2"	-	-	46	30	32	32	25	39	110	240	290	385	535	162
65	2 1/2"	-	-	70	46	49	49	39	60	205	445	540	715	1000	267
80	3"	-	-	82	53	57	57	45	70	205	445	540	715	1000	390
100	4"	-	-	96	62	67	67	53	82	405	880	1075	1420	1950	700

CERTIFICATION	CONSTRUCTION STANDARDS	TEST STANDARDS
CE Certification acc. to PED 2014/68/EU Fire Safe Design acc. to API 607Ed.6/ISO 10497 ATEX II 2GD Design acc. to 2014/34/EU Fugitive Emissions Class B acc. to ISO 15848 CO1 (-46 °C to RT) Quality System Certified acc. to ISO 9001	ASME B16.34 ASME B1.20.1   ISO 7-1   ISO 228-1 ASME B16.25   ASME B36.10M ASME B16.11 ISO 5211	Valves are tested according to: EN 12266-1 Rate A and API 598  TESTS APPLIED: Hydrostatic and Pneumatic EN 10204 type 3.1 Certificate

Last revision available

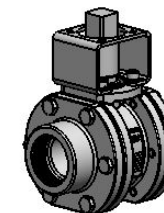
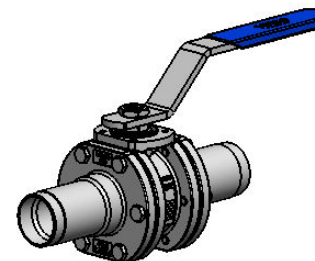
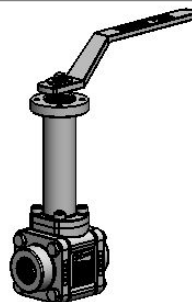

SERIE	CLASS	VERSION	PORT	DN	ENDS	BODY	BALL   STEM	BOLTING	SEATS   1 <sup>st</sup> SEAL	PACKING   2 <sup>nd</sup> SEAL O'RING	OPTIONS
XF		1	F - FB	010	<b>BUTTWELD</b>	A - A216 WCB	A - A479 410   A479 410	<b>A - B7</b>	1 - PTFE   PTFE	<b>1 - Grafite   Grafite   FKM</b>	A - 2 Opposite sides Flattened Ends
			R - RB	015	B1 - BW SCH 10	C - A351 CF3M	E - A351 CF8M   A564 S17400	<b>F - B8M d.2</b>	2 - TFM 1600   PTFE	2 - V TFM 1600   PTFE	C - Spring Return
3 - CL600				020	B2 - BW SCH 40	Z - Others	<b>F - A351 CF8M   A479 316</b>	G - B8 cl.2	<b>3 - CG-RPTFE   CG-RPTFE</b>	3 - V CG-RPTFE   CG-RPTFE	D - Simple Extension 60 mm
				025	B3 - BW SCH 80		G - A351 CF8   A479 304	C - B7M	4 - PEEK NATURE   CG-RPTFE		E - Extension 100 mm
				032	B4 - BW SCH 160*		Z - Others		5 - PEEK MOD   CG-RPTFE		F - Bracket Automation
				040	B6 - BW ISO 1127 S1			6 - DEVLON   CG-RPTFE		G - Gear Box	
				050	B9 - OTHERS			7 - UHMWPE   UHMWPE		H - Actuators	
3 - CL400				065	<b>SOCKETWELD</b>						I - Switch Box / Limit Switches
				080	C1 - SW ASME B16.11						L - Locking Lever/Handle
2 - CL300				100	C9 - OTHERS						O - Oval Lever/Handle
					<b>THREADED</b>						R - Bare Shaft / Bare Stem
					D1 - BSP - ISO 228/1						S - Solenoid Valve
					D2 - BSPT - ISO 7/1						T - Upstream Relief Hole
					D3 - NPT - B1.20.1						W - "V" Ball Port
					D9 - OTHERS						Y - Full Execution SS.316
					<b>INTEGRAL NIPPLE**</b>						Z - Others
					N1 - BW SCH 10						
					N2 - BW SCH 40						
					N3 - BW SCH 80						
					N4 - BW SCH 160*						
					N6 - BW ISO 1127 S1						
					N9 - OTHERS						
					<b>WELDED BLOCK</b>						
					W100 - BLOCK 100						
					W500 - BLOCK 500						

\* Sch 160 up to DN 50

\*\*Except DN 10

Example:

**XF31F015B1D3AFA31E**

**XF21F080N1N1CFF12**

**INDUSTRIAL RANGE**

**CF Series**  
2 split body - Floating  
CI 150/300  
DN ½" (15) to 4" (100)



**BF Series**  
2 split body - Floating  
CI 150 to 600  
DN ½" (15) to 6" (150)



**SF Series**  
3 pieces bolted - Floating  
CI 150 to 800  
DN ¾" (10) to 6" (150)



**HF Series**  
3 pieces bolted - Floating  
CI 1500/2500  
DN ¾" (10) to 2" (50)

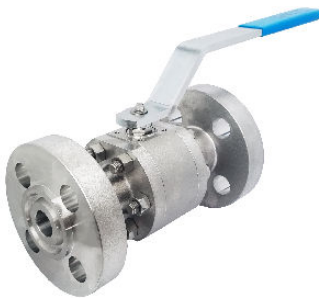

**ST Series**  
Multi-ways - Floating  
CI 150 to 600  
DN ¾" (10) to 2" (50)

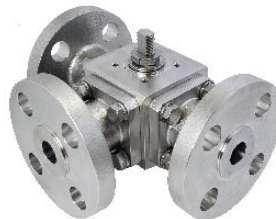

**VTR Series**  
3 pieces bolted - Trunnion  
CI 150 to 2500  
DN ½" (15) to 12" (300)



**OTHER RANGE**

**SANITARY RANGE**  
XP / RP / LP / MP



**CRYOGENIC RANGE**  
CCF / CBF / CXF / CSF / CVTR



**METALLIC SEATS RANGE**  
CFM / BFM / XFM / SFM / VTM



