

AIR AND GAS FLOAT TRAPS FA21.1 (SG iron 1/2" – 1"; DN 15 – 25)

DESCRIPTION

The FA21.1 is a series of fully automatic ball float traps specially designed for condensate drainage in compressed air and gas systems. Typical applications include aftercoolers, separators and compressed air mains.

MAIN FEATURES

Modulating discharge.
Unaffected by sudden or wide load and pressure variations.
Flow direction can be easily changed by repositioning the body in relation to the mechanism and cover.

OPTIONS: Metal to metal sealing.
Equalizing (vent) and drain connections.
BDV – Blowdown valve.
AFZ – Anti-freeze device.
FLL – Float lifting lever.

USE: Compressed air and other non corrosive gases compatible with the construction.

AVAILABLE MODELS: FA21.1-4,5 , 10 and 14 – SG iron.

SIZES: 1/2" to 1"; DN 15 to DN 25.

CONNECTIONS: Female threaded ISO 7 Rp or NPT.
Flanged EN 1092-1/-2 PN 16.
Flanged ASME B16.42/B16.5 Class 150.

INSTALLATION: Inline horizontal or vertical installation.
Angled horizontal or vertical installation.
See IMI – Installation and maintenance instructions.

MAX. ΔP: FA21.1-4,5 – 4,5 bar
FA21.1-10 – 10 bar
FA21.1-14 – 14 bar

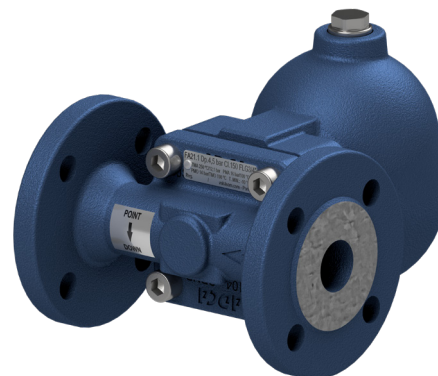

CE MARKING – GROUP 2 (PED – European Directive)

PN 16	Category
1/2" to 1" – DN 15 to 25	SEP

BODY LIMITING CONDITIONS

W/ FORGED CAST STEEL BODY		W/ SG IRON BODY		RELAT. TEMP.
THREADED / FLANGED PN 16 *	FLANGED CLASS 150 **	FLANGED PN 16 ***	FLANGED CLASS 150 ****	
ALLOWABLE PRESSURE	ALLOWABLE PRESSURE	ALLOWABLE PRESSURE	ALLOWABLE PRESSURE	
14,8 bar	17,7 bar	16 bar	16 bar	100 °C
14 bar	15,8 bar	15,5 bar	14,8 bar	150 °C
13,3 bar	14 bar	14,7 bar	13,9 bar	200 °C
12,1 bar	12,1 bar	13,9 bar	12,1 bar	250 °C

PMO – Max. operating press.: 14 bar; TMO – Max. operating temp.: 198 °C.
* Acc. to EN 1092-1:2018; ** Acc. to EN 1759-1:2004; *** Acc. to EN 1092-2:2018;
**** Acc. to ASME B16.42.

FLOW RATE CAPACITY (kg/h)										
MODEL	SIZE	DIFFERENTIAL PRESSURE (bar)								
		0,5	1	1,5	2	4,5	7	10	12	14
FA21.1-4,5	1/2" to 1" – DN 15 to 25	455	644	788	910	1366	–	–	–	–
FA21.1-10	1/2" to 1" – DN 15 to 25	285	403	494	570	856	1068	1276	–	–
FA21.1-14	1/2" to 1" – DN 15 to 25	215	304	372	430	645	805	962	1054	1139

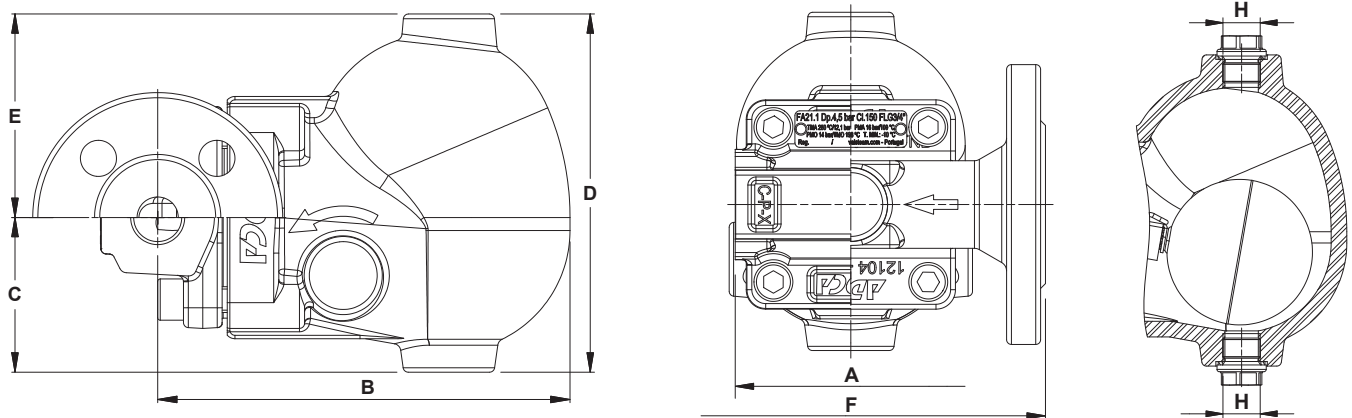

Inline design

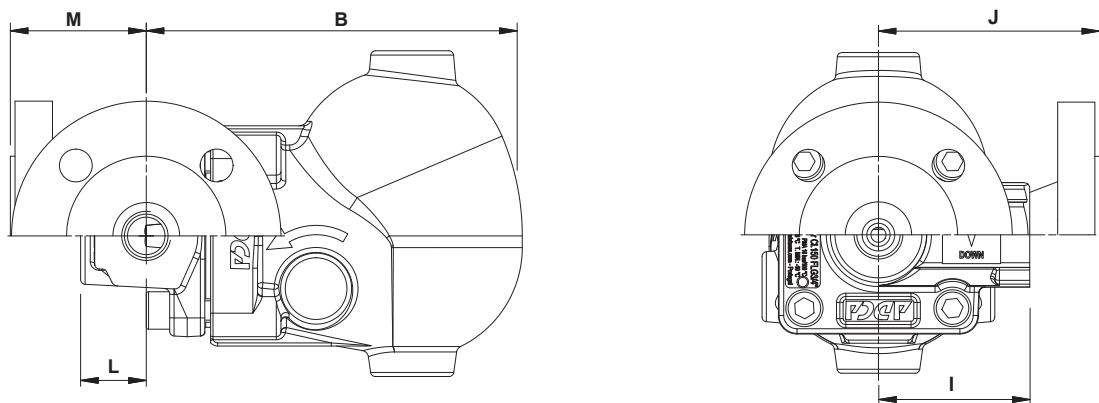

Angled design

DIMENSIONS (mm) – INLINE DESIGN											
SIZE	THREADED / SW						PN 16		CLASS 150		
	A	B	C	D	E	H *	WEIGHT (kg)	F	WEIGHT (kg)	F	WEIGHT (kg)
1/2" – DN 15	95	160	60	139	79	3/8"	4,9	150	6,2	150	5,8
3/4" – DN 20	95	160	60	139	79	3/8"	4,8	150	6,7	150	6,1
1" – DN 25	95	160	60	139	79	3/8"	4,7	160	7,4	160	7,2

DIMENSIONS (mm) – ANGLED DESIGN														
SIZE	THREADED / SW								PN 16			CLASS 150		
	B	C	D	E	H *	I	L	WGT. (kg)	J	M	WGT. (kg)	J	M	WGT. (kg)
1/2" – DN 15	160	60	139	79	3/8"	65	28	4,9	95	58	6,5	100	63	6
3/4" – DN 20	160	60	139	79	3/8"	65	28	4,9	95	58	7	100	63	6,4
1" – DN 25	160	60	139	79	3/8"	65	28	4,9	95	58	7,5	100	63	6,9

* As standard, in versions with EN flanges or female ISO 7 Rp threads, these connections are female threaded ISO 228. In versions with ASME flanges, female NPT threads or SW, these connections are female threaded NPT.

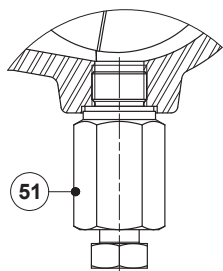
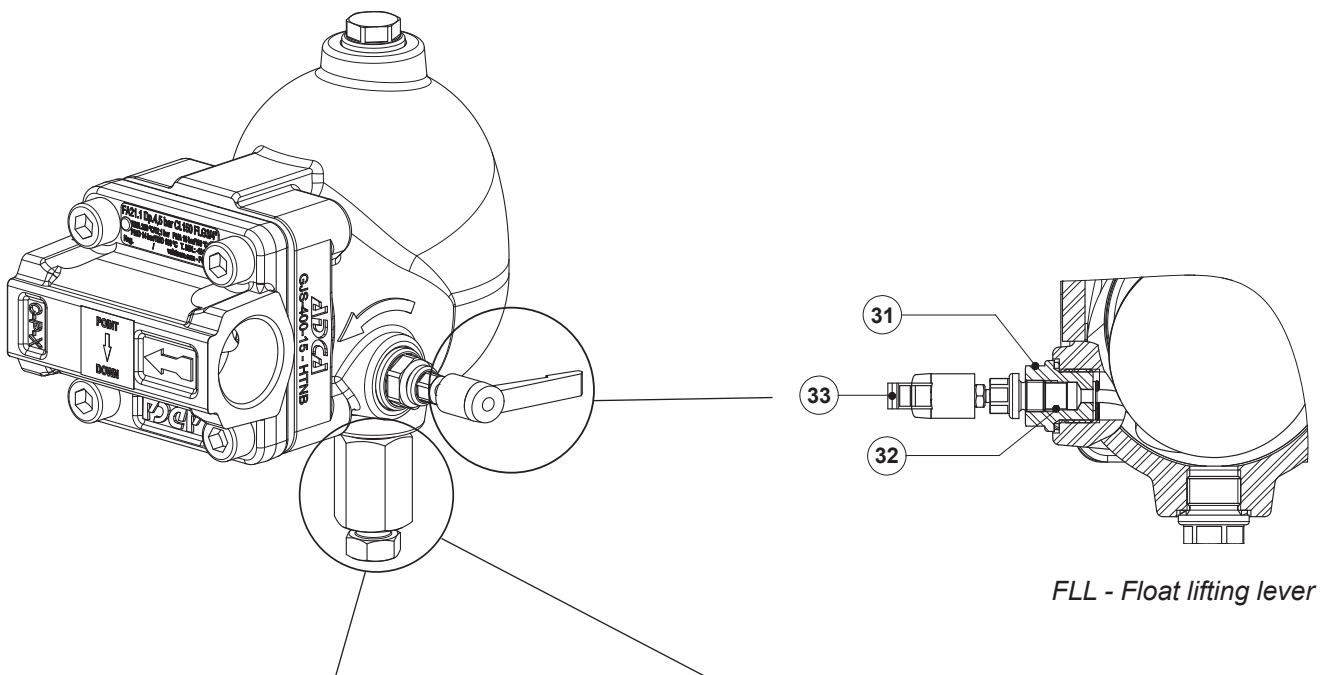
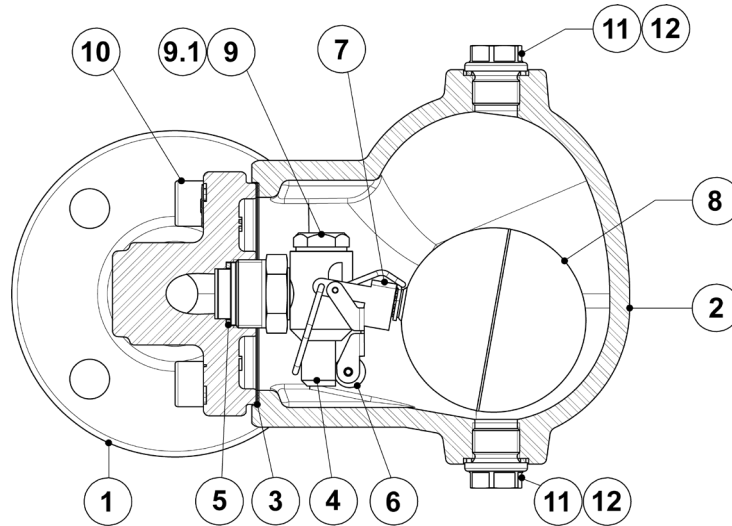

*BDV - Blowdown valve
 (Manual)*

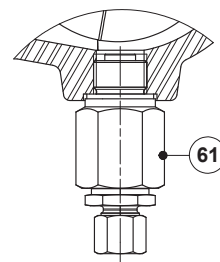

*AFZ - Anti-freeze device
 (Automatic)*

MATERIALS		
POS. N°	DESIGNATION	MATERIAL
1	Body (inline flanged)	GJS-400-15 / 0.7040
	Body (inline threaded)	P250GH / 1.0460
	Body (angled)	P250GH / 1.0460
2	Cover	GJS-400-15 / 0.7040
3	* Gasket	Stainless steel / Graphite
4	* Seat	AISI 303 / 1.4305
5	* Gasket	Copper
6	* Valve ball	AISI 316 / 1.4401; Viton
7	* Lever	AISI 304 / 1.4301
8	* Float	AISI 304 / 1.4301
9	Plug	AISI 316L / 1.4404
9.1	Gasket	Copper
10	Bolts	Zinc plated steel
11	Plug	AISI 316L / 1.4404
12	** Gasket	Copper; AISI 304 / 1.4301
31	Lever mechanism	AISI 303 / 1.4305; AISI 304 / 1.4301; AISI 316L / 1.4404
32	Packing	Graphite
33	Lever	Plastic
51	Blowdown valve	AISI 303 / 1.4305; AISI 316L / 1.4404
61	Anti-freeze device	AISI 303 / 1.4305; AISI 316L / 1.4404

* Available spare parts; ** Not applicable in NPT version.

FLOW DIRECTION

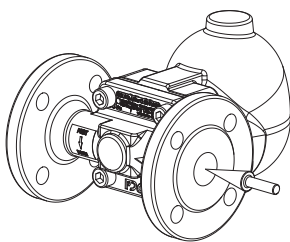

IR - Horizontal from right to left

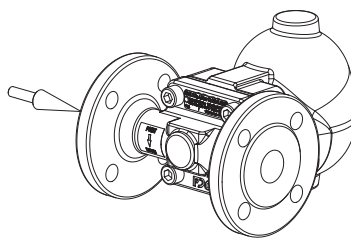

IL - Horizontal from left to right

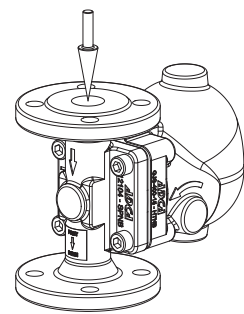

IT - Vertical from top to bottom

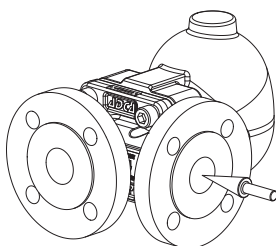

AR - Angled from right to front

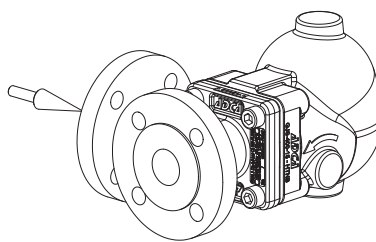

AL - Angled from left to front

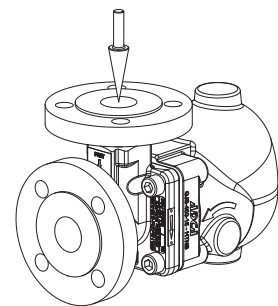

AT - Angled from top to front

ORDERING CODES FA21.1									
Model	FA211	2	V	XX	X	IR	A	15	
FA21.1 – GJS-400-15 / 0.7040 SG iron	FA211								
Differential pressure									
4,5 bar		2							
10 bar		3							
14 bar		4							
Valve sealing									
FPM / Viton (standard)			V						
Metal to metal			M						
Cover connections									
None				XX					
3/8" threaded connections on top and bottom, closed with plugs (mandatory if any options are considered)				10					
Options									
If any, these have specific separate ordering codes, please refer to the appropriate documentation									
FLL - Float lifting lever									
None					X				
Lifting lever on the right side (when facing the steam trap body)					R				
Lifting lever on the left side (when facing the steam trap body)					L				
Flow direction									
Inline horizontal from right to left (standard)						IR			
Inline horizontal from left to right						IL			
Inline vertical from top to bottom						IT			
Angled from right to front						AR			
Angled from left to front						AL			
Angled from top to front						AT			
Pipe connections									
Female threaded ISO 7 Rp							A		
Female threaded NPT							C		
Flanged EN 1092-1/-2 PN 16							L		
Flanged ASME B16.42/B16.5 Class 150							U		
Size									
1/2" or DN 15								15	
3/4" or DN 20								20	
1" or DN 25								25	
Special valves / Extras									
Full description or additional codes have to be added in case of a non-standard combination									E